



Plastic Modular

BELT

Catalog

Innovative
belt solutions
for every industry
& application

Plastic Modular Belt Catalog

Innovative belt solutions for every
industry & application

Standard

	Side flexing both directions		Backflex radius		Solid lockpin
	Side flexing one travel direction		Sprockets		Snap Pin A1
	Straight running both directions		Two-part sprockets		Snap Pin A2
	Straight running one travel direction		Retainer ring		G-lock
	Patent pending or patented		Rubber inserts		Rodlock
	Pin diameter		Idler		Trilock
	Pitch		Pin		Endlock
	Materials		Lockpin		Radiuslock

Accessories











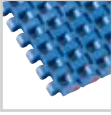
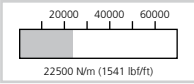

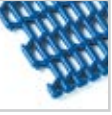
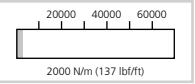

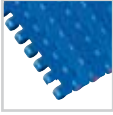
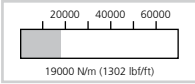

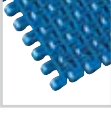
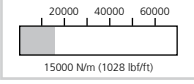

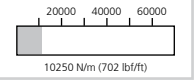
	Tab		Finger plate		Reinforcement link
	Product support		Side guard		Lane divider

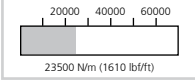
Standard and alternative Belt Colors

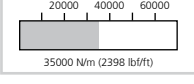
B Blue	G Grey	O Orange
BR Brown	K Black	P Purple
D Red	LG Light Grey	T Tan (Beige)
DG Dark Grey	I Ivory	W White
E Green	N Natural	Y Yellow
DD Dark Red	DB Dark Blue	LB Light Blue

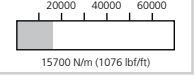

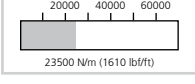







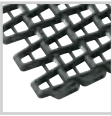
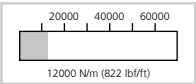

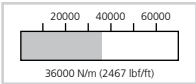

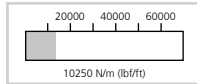

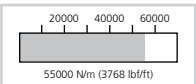

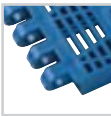
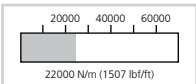
Straight running Belt Overview

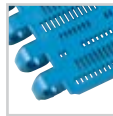
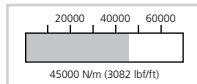
pages 5-7

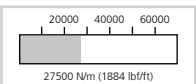
<p>uni M-TTB</p>  <p>pages 20-23</p> <p>Pitch 12.7 mm (0.50 in.)</p> <p>Strength Index (POM)</p>  <p>22500 N/m (1541 lbf/ft)</p>  <p>Straight running</p>	<p>uni M-PNB M1</p>  <p>pages 24-27</p> <p>Pitch 12.7 mm (0.50 in.)</p> <p>Strength Index (POM)</p>  <p>2000 N/m (137 lbf/ft)</p>  <p>Straight running</p>	<p>uni M-QNB</p>  <p>pages 28-31</p> <p>Pitch 12.7 mm (0.50 in.)</p> <p>Strength Index (POM)</p>  <p>19000 N/m (1302 lbf/ft)</p>  <p>Straight running</p>
<p>uni M-SNB M3</p>  <p>pages 32-35</p> <p>Pitch 12.7 mm (0.50 in.)</p> <p>Strength Index (POM)</p>  <p>15000 N/m (1028 lbf/ft)</p>  <p>Straight running</p>	<p>uni Light</p>  <p>pages 36-41</p> <p>Pitch 19.05 mm (0.75 in.)</p> <p>Strength Index (POM)</p>  <p>10250 N/m (702 lbf/ft)</p>  <p>Straight running</p>	<p>uni S-MPB</p>  <p>pages 42-45</p> <p>Pitch 25.4 mm (1.00 in.)</p> <p>Strength Index (POM)</p>  <p>23500 N/m (1610 lbf/ft)</p>  <p>Straight running</p>
<p>uni QNB</p>  <p>pages 46-51</p> <p>Pitch 25.4 mm (1.00 in.)</p> <p>Strength Index (POM)</p>  <p>35000 N/m (2398 lbf/ft)</p>  <p>Straight running</p>	<p>uni CNB</p>  <p>pages 52-56</p> <p>Pitch 25.4 mm (1.00 in.)</p> <p>Strength Index (POM)</p>  <p>15700 N/m (1076 lbf/ft)</p>  <p>Straight running</p>	<p>uni SNB M2</p>  <p>pages 57-63</p> <p>Pitch 25.4 mm (1.00 in.)</p> <p>Strength Index (POM)</p>  <p>23500 N/m (1610 lbf/ft)</p>  <p>Straight running</p>

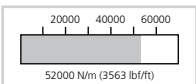

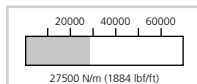

Straight running Belt Overview

pages 5-7

<p>uni OWL</p>  <p>pages 64-67</p> <p>Pitch 27.9 mm (1.10 in.)</p> <p>Strength Index (POM)</p>   <p>Straight running</p>	<p>uni SSB</p>  <p>pages 68-73</p> <p>Pitch 38.1 mm (1.50 in.)</p> <p>Strength Index (POM)</p>   <p>Straight running</p>	<p>uni Light EP</p>  <p>pages 74-77</p> <p>Pitch 38.1 mm (1.50 in.)</p> <p>Strength Index (POM)</p>   <p>Straight running</p>
<p>uni L-SNB</p>  <p>pages 78-82</p> <p>Pitch 50.0 mm (1.97 in.)</p> <p>Strength Index (POM)</p>   <p>Straight running</p>	<p>uni OPB</p>  <p>pages 83-89</p> <p>Pitch 50.0 mm (1.97 in.)</p> <p>Strength Index (POM)</p>   <p>Straight running</p>	<p>uni BLB</p>  <p>pages 90-94</p> <p>Pitch 50.8 mm (2.00 in.)</p> <p>Strength Index (POM)</p>   <p>Straight running</p>
<p>uni RTB</p>  <p>pages 95-98</p> <p>Pitch 50.8 mm (2.00 in.)</p> <p>Strength Index (POM)</p>   <p>Straight running</p>	<p>uni CPB</p>  <p>pages 99-103</p> <p>Pitch 50.8 mm (2.00 in.)</p> <p>Strength Index (POM)</p>   <p>Straight running</p>	<p>uni MPB</p>  <p>pages 104-112</p> <p>Pitch 50.8 mm (2.00 in.)</p> <p>Strength Index (POM)</p>   <p>Straight running</p>

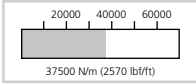

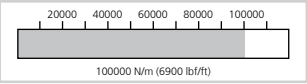



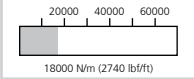

Straight running Belt Overview

pages 5-7

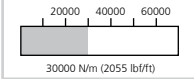
<p>uni X-MPB</p>  <p>pages 113-116</p> <p>Pitch 63.5 mm (2.50 in.)</p> <p>Strength Index (POM)</p>   <p>Straight running</p>	<p>uni XLB</p>  <p>pages 117-121</p> <p>Pitch 63.5 mm (2.50 in.)</p> <p>Strength Index (POM)</p>   <p>Straight running</p>	

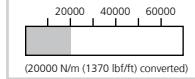

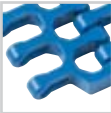
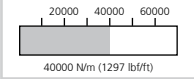







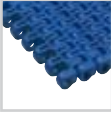
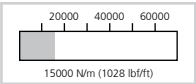

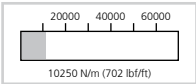

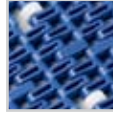
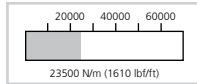

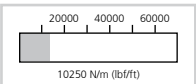
Side flexing Belt Overview

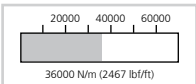
page 8

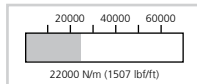
<p>uni Flex ASB</p>  <p>pages 122-126</p> <p>Pitch 25.4 mm (1.00 in.)</p> <p>Strength Index (POM), Straight running</p>  <p>18000 N/m (2740 lbf/ft)</p> <p>Strength Index (Max), Side flexing: 2040 N (459 lbf)</p>  <p>Side flexing</p>	<p>uni Flex SNB</p>  <p>pages 127-136</p> <p>Pitch 25.4 mm (1.00 in.)</p> <p>Strength Index (POM), Straight running</p>  <p>30000 N/m (2055 lbf/ft)</p> <p>Strength Index (Max), Side flexing: (SS reinf.) 3360 N (756 lbf) (all plastic) 1000 N (225 lbf)</p>  <p>Side flexing</p>	<p>uni Flex ONE</p>  <p>pages 137-147</p> <p>Pitch 38.1 mm (1.50 in.)</p> <p>Strength Index (POM), Straight running</p>  <p>(20000 N/m (1370 lbf/ft) converted)</p> <p>Strength Index (Max), Side flexing: 3800 N (855 lbf)</p>  <p>Side flexing</p>
<p>uni Flex L-ASB</p>  <p>pages 148-152</p> <p>Pitch 50.8 mm (2.00 in.)</p> <p>Strength Index (POM), Straight running</p>  <p>40000 N/m (1297 lbf/ft)</p> <p>Strength Index (Max), Side flexing: 3110 N (700 lbf)</p>  <p>Side flexing</p>		

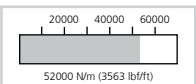
Straight running | Side flexing Belt Overview

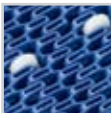
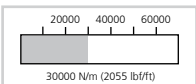
page 9

<p>uni M-SNB M2</p>  <p>page 153</p> <p>Pitch 12.7 mm (0.50 in.)</p> <p>Strength Index (POM)</p>  <p>15000 N/m (1028 lbf/ft)</p>  <p>Straight running</p>	<p>uni Light</p>  <p>pages 154-156</p> <p>Pitch 19.1 mm (0.75 in.)</p> <p>Strength Index (POM)</p>  <p>10250 N/m (702 lbf/ft)</p>  <p>Straight running</p>	<p>uni SNB M2</p>  <p>page 157</p> <p>Pitch 25.4 mm (1.00 in.)</p> <p>Strength Index (POM)</p>  <p>23500 N/m (1610 lbf/ft)</p>  <p>Straight running</p>
<p>uni Light EP</p>  <p>pages 158-162</p> <p>Pitch 38.1 mm (1.50 in.)</p> <p>Strength Index (POM)</p>  <p>10250 N/m (lbf/ft)</p>  <p>Straight running</p>	<p>uni SSB</p>  <p>page 163</p> <p>Pitch 38.1 mm (1.50 in.)</p> <p>Strength Index (POM)</p>  <p>36000 N/m (2467 lbf/ft)</p>  <p>Straight running</p>	<p>uni OPB</p>  <p>pages 164-168</p> <p>Pitch 50.0 mm (1.97 in.)</p> <p>Strength Index (POM)</p>  <p>22000 N/m (1507 lbf/ft)</p>  <p>Straight running</p>
<p>uni CPB</p>  <p>page 169</p> <p>Pitch 50.8 mm (2.00 in.)</p> <p>Strength Index (POM)</p>  <p>52000 N/m (3563 lbf/ft)</p>  <p>Straight running</p>	<p>uni Flex SNB</p>  <p>page 170</p> <p>Pitch 25.4 mm (1.00 in.)</p> <p>Strength Index (POM)</p>  <p>30000 N/m (2055 lbf/ft)</p>  <p>Side flexing</p>	

uni Belt Material Selection	pages 11-14
uni Pin Material Selection	page 15
uni Reinforcement Link Material Selection	page 16
uni Rubber Material Selection	page 16
Approvals	page 17
Ordering Guide	pages 18-19
uni Retainer Rings	page 171
Application Data Sheet (Metric)	pages 172-173
Application Data Sheet (Imperial)	pages 174-175
Notes	page 176
Disclaimer	page 177
Warnings	page 177
Patents, Trade Marks	page 178

uni Belt Material Selection

Material grades	Temp °C	Temp °F	Load/ permissible load index	FDA
POM - Polyoxymethylen ^{4/}	-40 to +90	-40 to +194	100% POM	✓
POM-DK - Polyoxymethylen	-40 to +90	-40 to +194	100% POM	-
POM-AS/NLAS - Semi conductive materials	-40 to + 90	-40 to +194	100% POM	-
POM-EC - Electrical conductive materials	-40 to + 90	-40 to +194	50% POM	-
PP - Polypropylene ^{2/ 3/}	+1 to +104	+34 to +219	100% PP	✓
PP-I - Polypropylene	-10 to +80	+14 to +176	80% PP	✓
PPMI - Metal detectable polypropylene	-10 to +80	+14 to +176	70% PP	✓
PPHW - Hot water polypropylene	+1 to +104	+34 to +219	100% PP	✓
PE - Polyethylene	-50 to +80	-58 to +176	100% PE	✓
PEMI - Metal detectable polyethylene	-50 to +80	-58 to +176	80% PE	✓
GR - Glass reinforced polyester ^{1/}	-40 to +125	-40 to +257	70% POM	✓
PBT - Polyester ^{1/}	-40 to +100	-40 to +212	-	✓
AR - Glass reinforced polypropylene	+1 to +80	+33 to +176	50% POM	-
FR - Flame retardant polyamide	+1 to +104	+34 to +219	90% POM	-
PVDF - Polyvinylidenfluoride	-40 to +100	-40 to +212	100% POM	✓
PA6 - Polyamide	-40 to +120	-40 to +248	100% POM	✓
PA6-GF - Polyamide glass reinforced	-40 to +120	-40 to +248	100% POM	-
PA6.6 - Polyamide	-40 to +140	-40 to +284	100% POM	✓
PA6.6-H - Polyamide	-40 to +160	-40 to +320	100% POM	-
PA6.6-GFH - Polyamide	-40 to +180	-40 to +356	100% POM	✓

^{1/} Max. temperature in water +60°C (+140°F).

^{2/} Avoid impact below +8°C (+46°F).

^{3/} Dry. In wet and hot applications use PPHW.

Please, note that the temperature has an effect on the mechanical properties of the belts.

^{4/} POM-D/DI/LF/SL/FIN/L/S/SX.

POM	POM-D	POM-DI
<p>POM is a thermoplastic material with very good mechanical and thermal properties. The material can also be characterised by great strength, elasticity and dimensional stability. POM is resistant to a wide selection of chemicals. POM has good bearing qualities, low coefficient of friction and a good resistance to wear.</p>	<p>POM polymers with self-lubricating components.</p>	<p>POM polymers with self-lubricating components and improved impact resistance.</p>

uni Belt Material Selection

<p>POM-DK</p> <p>O K</p> <p>POM-DK is a reinforced POM polymer designed for applications where high wear resistance is needed and/or high conveyor speeds are required. The material is typically used for wear parts on side flexing belts or in applications where very high wear resistance is required.</p>	<p>POM-LF</p> <p>B BR D DG E G K N O P T W Y</p> <p>POM polymers with improved self-lubricating components.</p>	<p>POM-SLF</p> <p>B BR D DG E G K N O P T W Y</p> <p>POM polymers with self-lubricating additives to obtain the lowest possible friction resistance.</p>
<p>POM-NL</p> <p>K G</p> <p>POM polymers with no lubricant suitable for applications where you want to ensure that no lubricant may affect the product adhesion or the like. Ammeraal Beltech Modular's standard POM-NL holds a surface resistivity of minimum 1×10^{14} Ohm according to IEC 60093/ASTM D257.</p>	<p>POM-AS</p> <p>K Y</p> <p>Semi conductive POM with self-lubricating components is used in applications where you want to avoid build-up of static electricity. POM-AS is normally used for man-riders belts to avoid discomfort; it can also be used in applications where you want to avoid products (such as thin plastic foils) "sticking" to the belt/chain. Ammeraal Beltech Modular's standard POM-AS holds a surface resistivity of 1×10^{11} Ohm according to IEC 60093/ASTM D257.</p>	<p>POM-NLAS</p> <p>K Y</p> <p>POM polymers contain no lubricant but do contain additives that reduce the electrical resistance and helps to dissipate static electricity. POM-NLAS holds a surface resistivity of 1×10^{11} Ohm according to IEC 60093/ASTM D257.</p>
<p>POM-S</p> <p>B BR D DG E G K N O P T W Y</p> <p>POM polymers contain low noise components, mainly used for the new uni Snap Link® without pins.</p>	<p>POM-SX</p> <p>W</p> <p>POM polymers with self-lubricating components. POM-SX will be the right solution where lower friction, higher load and lower noise compared to standard POM are requested. POM-SX will mainly be used for high load capacity uni Snap Link® without pins.</p>	<p>POM-EC</p> <p>K</p> <p>Electrical conductive POM is normally used in explosive areas where sparks and static must be avoided, such as areas with filling aerosol, camping gas, or the like. Ammeraal Beltech Modular's standard EC holds a surface resistivity of 1×10^6 Ohm according to IEC 60093/ASTM D257.</p>

uni Belt Material Selection

<p>PP</p> <p>B D E G K N O P T W Y</p> <p>Polypropylene is a thermoplastic material with very good chemical resistance properties. PP is an economical material for applications with high temperatures.</p>	<p>PP-I</p> <p>B D E G K N O P T W Y</p> <p>Polypropylene with improved impact resistance and improved properties at low temperatures. Use of PP-I in hot water should be avoided.</p>	<p>PPMI</p> <p>DB DD</p> <p>PPMI is a metal detectable polypropylene with improved impact resistance to allow detection with both metal detectors and X-ray machines in case of belt breakage. PPMI is used to increase safety in food processing equipment which will allow the user to detect if pieces of plastic from upstream conveyors have contaminated the conveyed product.</p>
<p>PPHW</p> <p>B D E G K N O P T W Y LB</p> <p>PPHW is a polypropylene which contains additives that reduce decomposition over time due to oxidization caused by metal ions in hot water applications like blanchers and cookers.</p>	<p>PE - Polyethylene</p> <p>B D E G K N O P T W Y</p> <p>Polyethylene is used in low temperature applications and where high impact resistance is required.</p>	<p>PE-I</p> <p>B D E G K N O P T W Y</p> <p>Polyethylene with improved impact resistance.</p>
<p>GR</p> <p>K N</p> <p>Glass reinforced polyester is a material with an extremely high resistance to wear and heat.</p>	<p>AR</p> <p>B K W</p> <p>AR is an acid resistant material which is used where very high chemical resistance is required. The limited mechanical strength of polypropylene is considerably improved by the glass fiber reinforcement.</p>	

uni Belt Material Selection

<p>FR</p> <p>N</p> <p>Flame retardant polyamide is a fire restricting material used in surroundings where there is a danger of the chain being ignited. The FR material is rated as V-0 which is the best classification according to UL 94 standard to avoid burning.</p>	<p>PVDF</p> <p>N</p> <p>Polyvinylidenfluoride is characterized by an especially high chemical resistance. Furthermore, PVDF has high wear resistance and good friction properties.</p>	<p>PA6</p> <p>B D LG K N T W</p> <p>Polyamide PA6 is a thermoplastic material. The combination of mechanical properties and chemical resistance makes this material suitable for many applications. Polyamide has a high resistance to wear and dynamic loads. This material is primarily used for sprockets.</p>
<p>PA6-GF</p> <p>B K</p> <p>This polyamide is reinforced with glass fiber. PA6-GF will be the right solution where higher stiffness and higher strength are required, compared to standard Polyamide. The combination of mechanical properties and chemical resistance makes this material suitable for many applications. Polyamide has a high resistance to wear and dynamic loads. Polyamide also has a larger working temperature range.</p>	<p>PA6.6</p> <p>B D N W</p> <p>Polyamide PA6.6 is a thermoplastic material with many fine properties. The material has a high resistance to wear, high strength and great stiffness. Furthermore, polyamide has a large temperature range.</p>	<p>PA6.6-H</p> <p>B D N W</p> <p>PA6.6-H is a polyamid which contains the same fine properties as PA6.6. The PA6.6-H improves upon PA6.6 in applications where higher temperature resistance is needed e.g. shrink tunnels.</p> <p><i>Note: PA materials will absorb water in wet environments which will cause expansion of the dimension with approx. 1-2%, depending on the temperature level and the humidity of the air. This is current for all Polyamide variations.</i></p>
<p>PA6.6-GFH</p> <p>K</p> <p>PA6.6 GFH is a special heat stabilized polyamid PA6.6 with glass fiber reinforcement. The base material is still the PA6.6 with its important properties, as high strength and great stiffness. The base material has a high resistance to wear, and the glass fiber contribute to increasing these wear properties. The unique PA6.6 GFH is heat resistant, and thus especially suitable for applications that are exposed to strong heat for a long time.</p>	<p>UV</p> <p>The UV stabilizer is an additive recommended for plastic materials used for outdoor applications. The UV stabilizer is able to protect materials against direct sunlight. The UV stabilizer is FDA approved and will increase the lifetime of plastic materials. The UV stabilizer is available for the most common materials such as POM, PP and PE.</p>	<p>UV-C</p> <p>This UV stabilizer is specially developed for applications that are exposed to UV-C light. The special UV lights is used in eg. the meat industry, where UV-C light is served to kill bacteria and microbes. The UV-C stabilizer holds an FDA approval and will increase the lifetime of the plastic material. This solution is only available in combination with POM material.</p>

uni Pin Material Selection

<p>Austenitic Stainless Steel</p> <p>SS304</p> <p>Austenitic quality containing 18% chrome and 8% nickel. Werkstoff no. 1.4301 AISI 304.</p> <p>$^{18}/_8$ CrNi steel is non-magnetic in the entire recommended temperature range. The austenitic quality has a very high degree of corrosion resistance in oxidizing surroundings. However, in connection with evaporation of chloride-containing fluids, the $^{18}/_8$ CrNi steel is not recommended, as stress corrosion can occur over time.</p>	<p>Austenitic Stainless Steel</p> <p>SS316</p> <p>Austenitic quality containing 18% chrome, 10% nickel and 3% molybdenum. Werkstoff no. 1.4404 AISI 316.</p> <p>$^{18}/_{10}$ CrNi steel with molybdenum is non-magnetic in the entire recommended temperature range. The austenitic quality has a very high degree of corrosion resistance in oxidizing surroundings. Molybdenum has been added to increase corrosion resistance particularly in chloride containing environments.</p>	<p>PP</p> <p>Polypropylene is a thermoplastic material with very good chemical resistance properties. Polypropylene is an economical material for applications with high temperatures.</p>
<p>PE</p> <p>Polyethylene is used in low temperature applications and where high impact resistance is required.</p>	<p>PA6.6</p> <p>Polyamide PA6.6 is a thermoplastic material with many fine properties. The material has a high resistance to wear, high strength and great stiffness. Furthermore, polyamide has a large temperature range.</p>	<p>GR</p> <p>Glass reinforced polyester is a material with an extremely high resistance to wear and heat.</p>
<p>PBT</p> <p>PBT is a polybutylene terephthalate material. This material has good friction and wear properties as well as excellent hardness and stiffness.</p>		

uni Reinforcement Link Material Selection

<p>Austenitic Stainless Steel</p> <p>SS316</p> <p>Austenitic quality containing 18% chrome, 10% nickel and 3% molybdenum Werkstoff no. 1.4404 AISI 316.</p> <p>¹⁸/₁₀ CrNi steel with molybdenum is non-magnetic in the entire recommended temperature range. The austenitic quality has a very high degree of corrosion resistance in oxidizing surroundings. Molybdenum has been added to increase corrosion resistance particularly in chloride containing environments.</p>		
--	--	--

uni Rubber Material Selection

Rubber code	Rubber color	Hardness (shore A)	Temperature range		FDA approved	Attachment to base link
			°C	°F		
01 N	Natural	64	-40 to +125°C	-40 to +257°F	✓	Mechanical
03 N	Natural	60	-40 to +80°C	-40 to +176°F	✓	Co-moulding
03 K	Black	60	-40 to +80°C	-40 to +176°F	✓	Co-moulding
05 I	Ivory	85	-40 to +80°C	-40 to +176°F	✓	Mechanical
09 K	Black	85	-40 to +125°C	-40 to +257°F	-	Mechanical

FDA

FDA US Food and Drug Administration

US Federal Agency approves materials for use with food contact.

The uni-chains product range holds the following FDA approved materials:

- POM-D, POM-DI, POM-LF, POM-SLF, POM-NL and POM-S
- PP, PP-I, PPMI, PPHW
- PE, PE-I, PEMI
- PVDF
- PA6, PA6.6, PA6.6GFH
- UV additive
- PBT

FDA & EC1935/2004

Ammeraal Beltech Modular A/S hereby declares that the materials in the belt type meet the requirements mentioned in Title 21: Code of Federal Regulations, issued by the FDA according to paragraph 177.2600 for all wrapped and unwrapped foodstuffs

The listed materials comply with the requirements:

- POM (D, DI, LF & SLF)
- PP & PPI
- PE & PEI
- PA6.6, PA6.6GFH

USDA

(US Department of Administration)

USDA evaluates and accepts products and equipment for use in the dairy, meat, and poultry industries. uni-chains belts listed on this page are included in the USDA's Accepted Meat and Poultry Equipment book as accepted for food contact and packaged goods respectively. In addition, USDA inspectors accept belt styles on an individual plant basis.

USDA Dairy Grading Branch has issued Equipment Acceptance Certificates for the belt types listed on this page under USDA Dairy Accepted.

USDA Accepted Meat and Poultry Equipment (Food Contact):

- uni SNB series
- uni OPB 4C, uni OPB 4V C, uni OPB 4V 23%, uni OPB 4V 36%, uni OPB 8C and uni OPB 8 25%

USDA Accepted Meat and Poultry Equipment (Packaged Product only)

- uni Light
- uni SNB series
- uni OPB 4C, uni OPB 4V C, uni OPB 4V 23%, uni OPB 4V 36%, uni OPB 8C and uni OPB 8 25%

USDA Dairy Approval

- uni MPB, uni MPB-G, uni MPB-GE, uni MPB-N, uni MPB-NE, uni MPB 18%, uni MPB 20%, uni MPB 22%
- uni CNB C, uni CNB 18%, uni CNB 22%

USDA Equipment Acceptance Certificate in compliance with NSF-3A-14159-003.

Hygiene requirements for design of mechanical belt conveyors used in meat and poultry processing.

The approval covers the following products:

- uni MPB Single Link[®] and bricklaid belts
- uni MPB Product Supports and Side Guards
- uni MPB Sprockets
- uni Flex ONE

Reference No. for Belt Systems

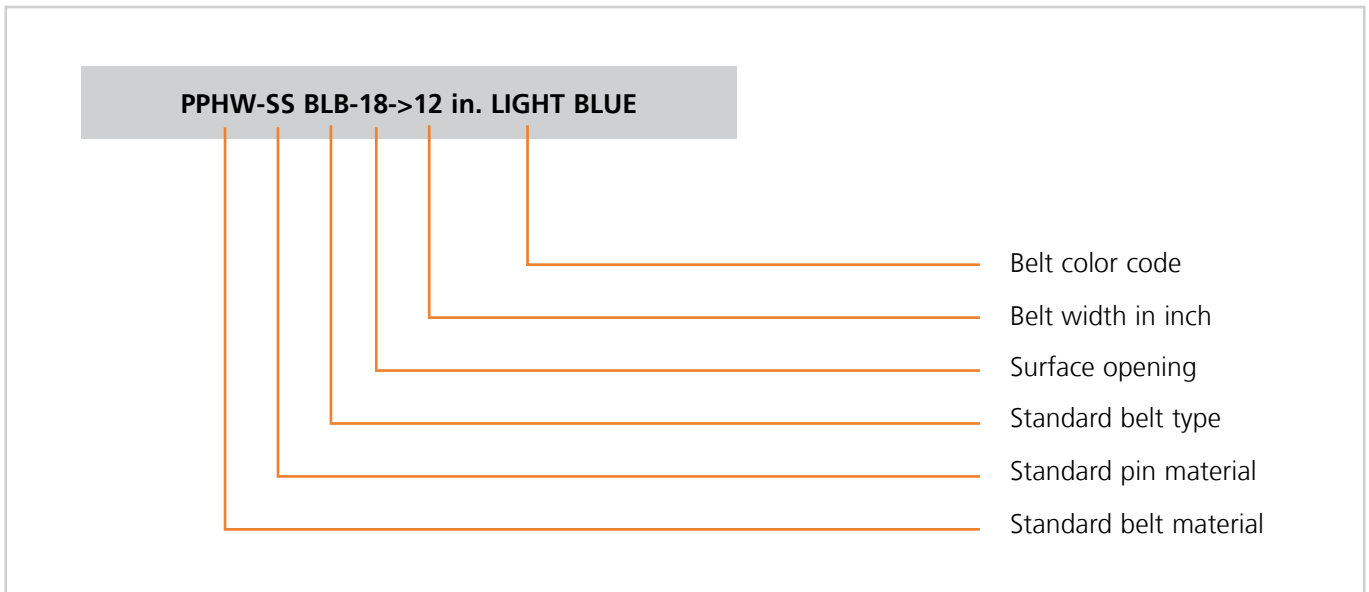

Series Codes

Pitch		Description	Code
mm	in.		
12.7	0.50	uni M-QNB system	11
12.7	0.50	uni M-SNB system	22
12.7	0.50	uni M-TTB system	64
12.7	0.50	uni M-PNB system	83
19.05	0.75	uni Light system	28
25.4	1.00	uni QNB system	14
25.4	1.00	uni CNB system	19
25.4	1.00	uni Flex SNB system	21
25.4	1.00	uni Flex ASB system	65
25.4	1.00	uni SNB M2/M2A system	75
25.4	1.00	uni S-MPB system	78
27.9	1.10	uni OWL system	66
38.1	1.50	uni SSB system	16
38.1	1.50	uni Light EP system	25
38.1	1.50	uni Flex ONE system	82
50.0	1.97	uni L-SNB system	20
50.0	1.97	uni OPB system	24
50.8	2.00	uni MPB system	18
50.8	2.00	uni RTB system	57
50.8	2.00	uni BLB system	60
50.8	2.00	uni Flex L-ASB system	67
50.8	2.00	uni CPB system	74
63.5	2.50	uni XLB system	73
63.5	2.50	uni X-MPB system	80

Belt Code Master

Example 1

60PPHWSS182LB

Series code	Belt material	Pin material	Opening in %	Variant	Width group	Color
60	PPHW	SS	18		2	LB
uni BLB	Hot water polypropylene	Stainless steel	18% opening		W > 304 mm (12 in.)	Light blue

Example 2

74NLASPA6600RU1K

Series code	Belt material	Pin material	Opening in %	Variant	Width group	Color
74	NLAS	PA6.6	00	RU	1	K
uni CPB	POM-NLAS	PA6.6	0% closed	Rough	6 in. < W < 12 in.	Black

Belt Description Master

Example 1

PPHW-SS BLB-18->12 in. LIGHT BLUE

Belt material	Pin material	Series	Opening in %	Variant	Width group	Color
PPHW	SS	uni BLB	18		> 12 in.	Light blue

Example 2

NLAS-PA66 CPB-00-ROUGH 6 in. < W < 12 in. BLACK

Belt material	Pin material	Series	Opening in %	Variant	Width group	Color
NLAS	PA66	uni CPB	00	Rough	6 in. < W < 12 in.	Black
			0% closed			

Pitch 12.7 mm (0.50 in.)



uni M-TTB and uni M-TTB CS

This new generation 0.5 in. pitch belts offers a unique, easy cleanable surface in combination with self-lubricating POM-D material. The 37% open belt can run over a 19 mm nose bar and is a perfect solution for food processing belts in cooling, freezing, drying or proofing applications

On top of this the curved surface of the uni M-TTB CS belt offers a reduced contact area of 10% and a smooth transfer. In combination with a 15 tooth sprocket, it forms a circle allowing a scraper against the belt.

The uni M-TTB series increase performance in the following industries

- Bakery industry including dough transport, cooling lines, internal transport, metal detectors and packaging lines
- Seafood applications including tray packing lines
- Meat & poultry applications including packaging lines
- Can making/filling lines and accumulation tables

Product features and operational benefits

- Improved strength enabling longer conveyors
- Standard POM-D material containing a self-lubricating component, improving non-stick characteristics and reducing friction
- Easy to clean thanks to improved hygienic design of the hinges
- Efficient product transfer and less product contact area (efficient cooling) with the curved surface design
- Easy retrofitting

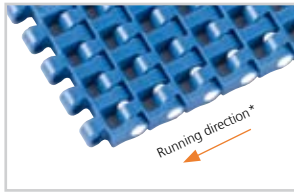
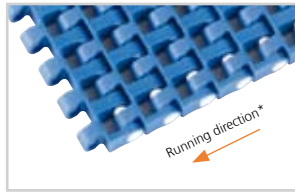
Standard Selection

uni M-TTB
Surface opening 37%

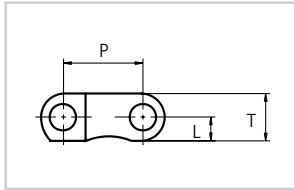
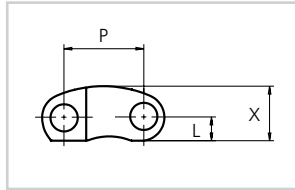
uni M-TTB CS
Surface opening 37%

* Running in both directions is possible. Ammeraal Beltech Modular recommends this travel direction.

Dimensional Sketches

uni M-TTB

uni M-TTB CS
Dimensions

	mm	in.
P	12.7	0.50
T	7.5	0.29
X	8.8	0.35
L	3.8	0.15



Straight running



12.7 mm (0.50 in.)



See page 11



Snap Pin A1

 \varnothing 4 mm (0.16 in.)

 uni M-TTB: 12.5 mm (0.49 in.)
uni M-TTB CS: 15.0 mm (0.59 in.)

See page 23



See page 171

Alternative

PA6.6 D
Standard Materials and Colors

Type	Standard materials and colors	Standard pin materials and colors
uni M-TTB	PP B	PP W
	POM-D B W	PP W
uni M-TTB CS	POM-D B	PP W

Standard Bricklaid Belt Widths (See next page for Single Link® widths)

mm	in.	mm	in.	mm	in.	mm	in.
77	3.0	384	15.1	769	30.3	1383	54.4
154	6.1	461	18.1	922	36.3	1537	60.5
231	9.1	538	21.2	1076	42.4	1690	66.5
308	12.1	615	24.3	1229	48.4	1844	72.6

On above belt width values, the belt width tolerance on standard materials is +0/-0.4% at 23°C/73°F.

uni M-TTB Single Link®

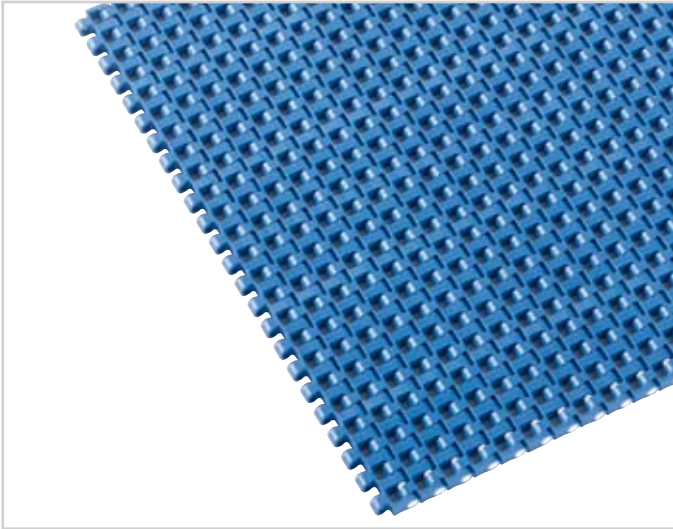

uni M-TTB Single Link® is available in the following standard width:

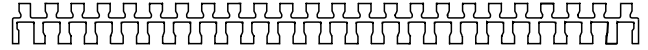

K1200 (308.0 mm (12.13 in.))

Belt Weights

Belt material	POM-D		PP	
Pin material	PP		PP	
	kg/m ²	lb/ft ²	kg/m ²	lb/ft ²
uni M-TTB uni M-TTB CS	5.8	1.19	4.2	0.86

Permissible Tensile Strength

Belt material	POM-D		PP	
Pin material	PP		PP	
	N/m	lbf/ft	N/m	lbf/ft
uni M-TTB uni M-TTB CS	22500	1541	13000	891

Nosebars Min. Dimensions

	mm	in.
A min.	19.0	0.75
B min.	4.0	0.16
C min.	40.6	1.60

Standard Sprockets

No. of teeth	Overall diameter		Pitch diameter		Hub diameter		Bore		Reference no. plastic
	mm	in.	mm	in.	mm	in.	mm	in.	
12	49.1	1.93	52.0	2.05	0	0	ø18.0/26.0	ø0.71/1.02	643PA6MTTB12221N00
15	61.1	2.41	64.6	2.54	0	0	ø18.0/30.0	ø0.71/1.18	643PA6MTTB15221N00
							sq 25.0	sq 0.98	643PA6MTTB15221N00M025S
							sq 25.4	sq 1.00	643PA6MTTB15221N00I100S
24	97.3	3.83	102.1	4.02	0	0	ø18.0/40.0	ø0.71/1.57	643PA6MTTB24221N00
							sq 38.1	sq 1.50	643PA6MTTB24221N00I150S
							sq 40.0	sq 1.57	643PA6MTTB24221N00M040S
36	145.7	5.74	152.3	6.00	0	0	ø18.0/70.0	ø0.71/2.76	643PA6MTTB36221N00
							sq 38.1	sq 1.50	643PA6MTTB36221N00I150S
							sq 40.0	sq 1.57	643PA6MTTB36221N00M040S

Note: All standard sprockets are supplied with keyway.

Placement of Wearstrips and Sprockets

No. of teeth	Minimum B-dimension for uni M-TTB CS		Wearstrip distance A	
	mm	in.	mm	in.
12	29.5	1.16	19.9	0.78
15	35.6	1.40	26.1	1.03
24	53.7	2.11	44.5	1.75
36	77.9	3.07	68.8	2.71

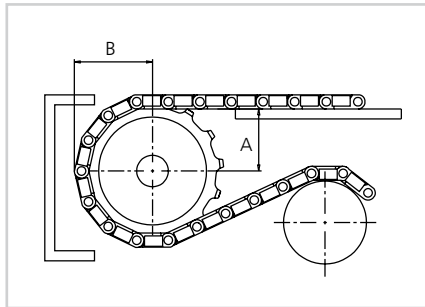

Other sprocket sizes are available upon request. Two-part sprockets are available upon request.

Max. Load per Sprocket

Belt material	POM		PP	
	N	lbf	N	lbf
uni M-TTB and uni M-TTB CS	1500	337	1000	225

Pitch 12.7 mm (0.50 in.)



uni M-PNB M1 – a new pinless design belt

This new pinless design is an exclusive uni-chains 0.5 in. pitch belt including the new uni Snap Link® feature. An open belt with no pin makes assembly and disassembly an exceptionally simple operation. The design of uni M-PNB M1 provides the maximum amount of open area for drainage and airflow with minimum product contact. The belt reduces dirt/debris compared to e.g. a wire mesh belt.

The uni M-PNB M1 belt with its unique features is the perfect belt in the following industries/ applications:

- Bakery applications including cooling lines, freezing lines and icing lines
- Poultry applications
- Seafood applications
- Weighing lines

Product features and operational benefits:

- Easy to clean with reduced downtime for cleaning
- Small transfer in nosebar applications
- uni Snap Link® feature eliminating pin walking and pins coming out
- uni Snap Link® feature improves belt weight uniformity

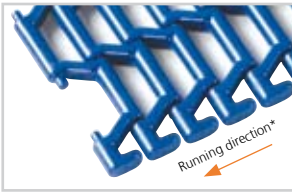
Standard Selection

* Running in both directions is possible. Ammeraal Beltech Modular recommends this travel direction.

uni M-PNB M1
Surface opening 40%

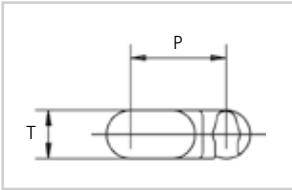
Dimensional Sketch

uni M-PNB M1

Dimensions

	mm	in.
P	12.7	0.50
T	6.4	0.25

- Straight running
- 12.7 mm (0.50 in.)
- Patent pending
- See page 11
- 12.5 mm (0.49 in.)
- See page 27
- See page 171

Standard Materials and Colors

Type	Standard material and colors
uni M-PNB M1	POM-S B W

Standard Bricklaid Belt Widths (See next page for Single Link® widths)

mm	in.	mm	in.	mm	in.	mm	in.	mm	in.
51	2.0	660	26.0	1269	50.0	1878	73.9	2487	97.9
102	4.0	711	28.0	1320	52.0	1929	75.9	2538	99.9
152	6.0	762	30.0	1371	54.0	1979	77.9	2588	101.9
203	8.0	812	32.0	1421	55.9	2030	79.9	2639	103.9
254	10.0	863	34.0	1472	58.0	2081	81.9	2690	105.9
305	12.0	914	36.0	1523	60.0	2132	83.9	2741	107.9
356	14.0	965	38.0	1573	61.9	2182	85.9	2791	109.9
406	16.0	1015	40.0	1624	63.9	2233	87.9	2842	111.9
457	18.0	1066	42.0	1675	65.9	2284	89.9	2893	113.9
508	20.0	1117	44.0	1726	68.0	2335	91.9	2944	115.9
559	22.0	1168	46.0	1776	69.9	2385	93.9	2994	117.9
609	24.0	1218	48.0	1827	71.9	2436	95.9	3045	119.9

On above belt width values, the belt width tolerance on standard materials is +0/-0.4% at 23°C/73°F.

uni M-PNB M1 Single Link®

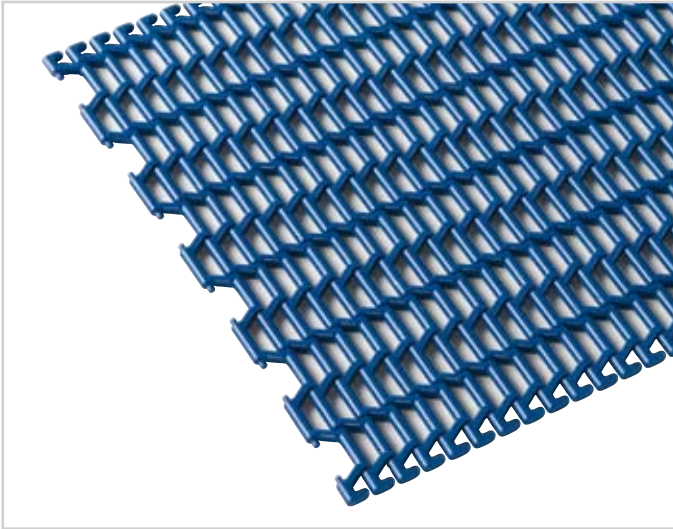

uni M-PNB M1 Single Link® is available in the following standard widths:

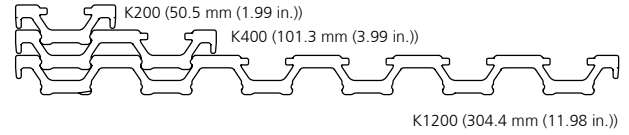

Belt Weights

Belt material	POM	
	kg/m ²	lb/ft ²
uni M-PNB M1	4.5	0.92

Permissible Tensile Strength

Belt material	POM	
	kg/m ²	lbf/ft
uni M-PNB M1	2000*	137*

* Please note: strength reduction if: - non-compliance with recommended sprocket distance (50.8 mm (2.00 in.)),
- use of nosebar

Nosebars Min. Dimensions

	mm	in.
A min.	25.0	0.98
B min.	5.0	0.20
C min.	46.0	1.81

Recommended Sprocket Distance

	mm	in.
S	50.8	2.00

Strength reduced if fewer sprockets are used.

Reduction of Strength

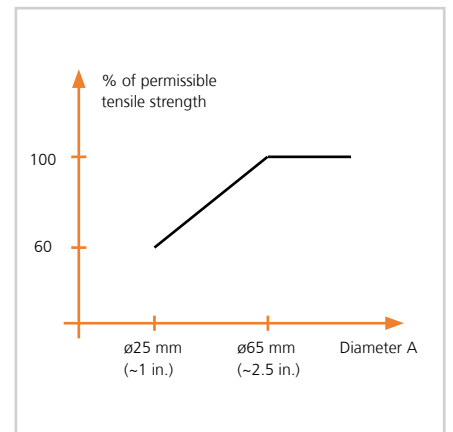

Standard Sprockets

No. of teeth	Pitch diameter		Overall diameter		Hub diameter		Bore		Reference no. plastic
	mm	in.	mm	in.	mm	in.	mm	in.	
8	33.2	1.31	34.0	1.34	25.0	0.98	∅10.0/15.0	0.39/0.59	833PA6MPNB08211N00
10	41.1	1.62	42.4	1.67	32.0	1.26	∅10.0/20.0	0.39/0.79	833PA6MPNB10211N00
14	57.1	2.25	59.0	2.32	50.0	1.97	∅10.0/20.0	0.39/0.79	833PA6MPNB14211N00
							sq 25.4	sq 1.00	833PA6MPNB14211N00IN100S
							sq 30.0	sq 1.18	833PA6MPNB14211N00M030S
17	69.1	2.72	71.3	2.81	60.0	2.36	∅18.0/45.0	0.71/1.77	833PA6MPNB17211N00
							sq 25.4	sq 1.00	833PA6MPNB17211N00IN100S
							sq 30.0	sq 1.18	833PA6MPNB17211N00M030S
19	77.2	3.04	79.5	3.13	70.0	2.76	∅18.0/50.0	0.71/1.97	833PA6MPNB19211N00
							sq 25.4	sq 1.00	833PA6MPNB19211N00IN100S
							sq 38.1	sq 1.50	833PA6MPNB19211N00IN150S
							sq 40.0	sq 1.57	833PA6MPNB19211N00M040S
24	97.3	3.83	99.8	3.93	90.0	3.54	∅18.0/70.0	0.71/2.76	833PA6MPNB24211N00
							sq 38.1	sq 1.50	833PA6MPNB24211N00IN150S
							sq 40.0	sq 1.57	833PA6MPNB24211N00M040S
							sq 50.8	sq 2.00	833PA6MPNB24211N00IN200S
28	113.4	4.46	116.1	4.57	105.0	4.13	∅18.0/80.0	0.71/3.15	833PA6MPNB28211N00
							sq 38.1	sq 1.50	833PA6MPNB28211N00IN150S
							sq 40.0	sq 1.57	833PA6MPNB28211N00M040S
							sq 50.8	sq 2.00	833PA6MPNB28211N00IN200S
							sq 60.0	sq 2.36	833PA6MPNB28211N00M060S
36	145.7	5.74	148.5	5.85	130.0	5.12	∅18.0/100.0	0.71/3.94	833PA6MPNB36211N00
							sq 38.1	sq 1.50	833PA6MPNB36211N01IN150S
							sq 40.0	sq 1.57	833PA6MPNB36211N01M040S
							sq 50.8	sq 2.00	833PA6MPNB36211N01IN200S
							sq 60.0	sq 2.36	833PA6MPNB36211N01M060S

Placement of Wearstrips and Sprockets

No. of teeth	Minimum B-dimension		Wearstrip distance A	
	mm	in.	mm	in.
8	20.2	0.80	12.2	0.48
10	24.0	0.94	16.4	0.65
14	31.9	1.26	24.6	0.97
17	37.9	1.49	30.8	1.21
19	41.9	1.65	35.9	1.37
24	52.0	2.05	45.1	1.78
28	60.0	2.36	53.2	2.09
36	76.1	3.00	69.4	2.73

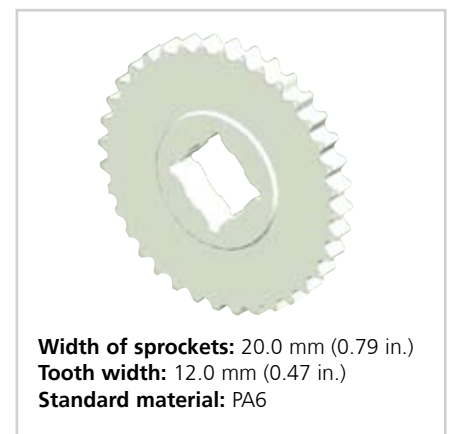
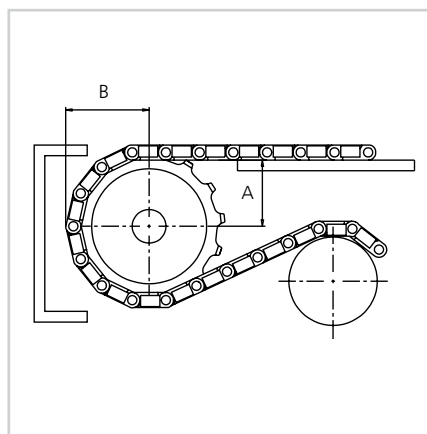

Other sprocket sizes are available upon request. Two-part sprockets are available upon request.

Pitch 12.7 mm (0.50 in.)



uni M-QNB – the high speed and tight transfer belt

The uni M-QNB is developed for tight transfer and high speed conveyors in both food and non food industries. The 0.5 in. pitch, bi-directional belt ensures product stability even in nosebar and high speed applications thanks to the rounded bottom surface.

The uni M-QNB belt increases performance in the following industries/applications:

- Bakery applications including dough handling, general conveyance and packaging lines
- Meat applications including tray pack lines and metal detectors
- Seafood applications including grading lines and weighing lines
- Beverage applications including depalletizers, accumulation tables and acceleration lines
- Can manufacturing applications including palletizers, mass handling and accumulation tables
- Corrugated applications including downstacker, corrugator take off, transfer car and WIP storage

Product features and operational benefits:

- Less vibration in high speed and nosebar applications
- Wear resistance in high speed applications with tight transfers
- Strong bi-directional belt for longer conveyors
- Unique lockpin locking system for easy maintenance
- Unique sprocket engagement reducing pulsation
- Unique Rubber Top eliminating wear and increasing friction in incline or acceleration applications

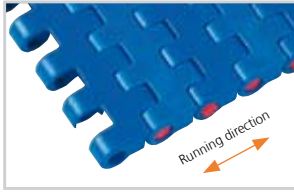
Standard Selection

uni M-QNB C

uni M-QNB Rubber Top

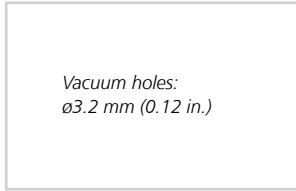
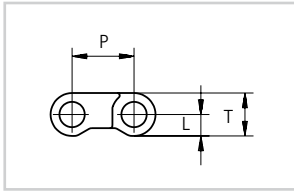
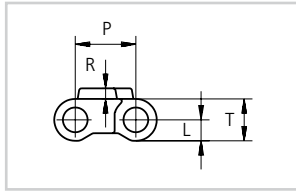
uni M-QNB Rubber Top

uni M-QNB Vacuum

Dimensional Sketches

uni M-QNB
uni M-QNB Vacuum

uni M-QNB Rubber Top
Dimensions

	mm	in.
L	4.4	0.17
P	12.7	0.50
R	2.2	0.09
T	8.8	0.35

- Straight running
- 12.7 mm (0.50 in.)
- ø5 mm (0.20 in.)
- Patent pending
- See page 11
- 20 mm (0.8 in.)
- See page 31
- See page 171
- 03** **K** **N** See page 16

Standard Materials and Colors

Type	Standard materials and colors	Standard pin materials and colors
uni M-QNB C	POM-SLF B	PA6.6 D
	PP W	PA6.6 N
	PP G	PA6.6 D
	PE N	PA6.6 N
	POM-EC K	PA6.6 D
uni M-QNB Rubber Top	PP G + 03 K	PA6.6 D
	PP W + 03 N	PA6.6 N
uni M-QNB Vacuum	PP G	PA6.6 D

Standard Bricklaid Belt Widths (See next page for Single Link® widths)

mm	in.	mm	in.	mm	in.	mm	in.	mm	in.	mm	in.
76	3.0	380	15.0	683	26.9	988	38.9	1292	50.9	1595	62.8
152	6.0	456	18.0	759	29.9	1063	41.9	1368	53.9	1670	65.7
228	9.0	531	20.9	835	32.9	1139	44.8	1443	56.8	-	-
304	12.0	607	23.9	912	35.9	1216	47.9	1519	59.8	-	-

On above belt width values, the belt width tolerance on standard materials is +0/-0.4% at 23°C/73°F.

uni M-QNB Single Link®

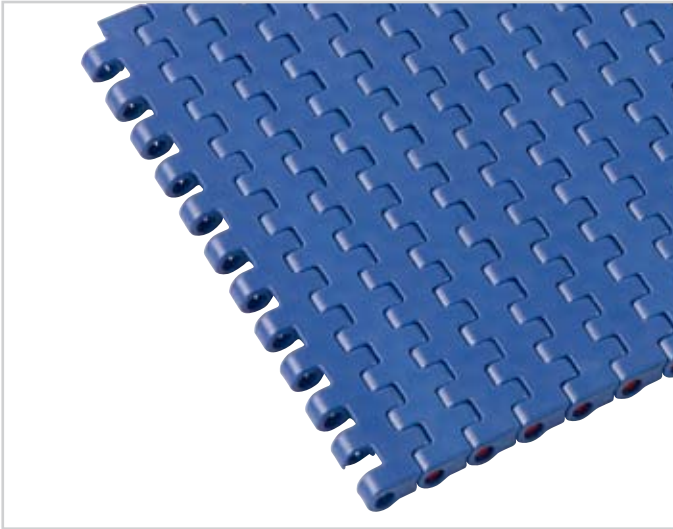

uni M-QNB Single Link® is available in the following standard widths:

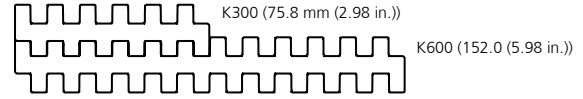

Belt Weights

Belt material	POM		PP		PE		EC	
Pin material	PA6.6		PA6.6		PA6.6		PA6.6	
	kg/m ²	lb/ft ²	kg/m ²	lb/ft ²	kg/m ²	lb/ft ²	kg/m ²	lb/ft ²
uni M-QNB uni M-QNB Vacuum	8.2	1.68	6.1	1.25	5.9	1.21	7.5	1.54
uni M-QNB Rubber Top	-	-	6.3	1.29	-	-	-	-

Permissible Tensile Strength

Belt material	POM		PP		PE		EC	
Pin material	PA6.6		PA6.6		PA6.6		PA6.6	
	N/m	lbf/ft	N/m	lbf/ft	N/m	lbf/ft	N/m	lbf/ft
uni M-QNB uni M-QNB Vacuum	19000	1302	13000	891	8000	548	14500	993
uni M-QNB Rubber Top	-	-	13000	891	-	-	-	-

Nosebars Min. Dimensions

	mm	in.
A min.	20.0	0.79
B min.	4.0	0.16
C min.	41.6	1.64

Standard Sprockets

No. of teeth	Pitch diameter		Overall diameter		Hub diameter		Bore		Reference no. plastic
	mm	in.	mm	in.	mm	in.	mm	in.	
10	41.8	1.65	41.5	1.63	28.0	1.10	ø10/18.0*	0.39/0.71*	223PA6MSNB210211N00
19	78.5	3.09	79.0	3.11	65.0	2.56	19.1/40.0*	0.75/1.57*	223PA6MSNB219211LG00
							sq 25.4	sq 1.00	223PA6MSNB219211N00I100S
							sq 38.1	sq 1.50	223PA6MSNB219211N00I150S
							sq 40.0	sq 1.57	223PA6MSNB219211N00M040S
28	115.4	4.54	116.2	4.57	65.0	2.56	ø19.1/40.0	0.75/1.57*	223PA6MSNB228211LG00
							sq 38.1	sq 1.50	223PA6MSNB228211N00I150S
							sq 40.0	sq 1.57	223PA6MSNB228211LG00M040S
					100.0	3.94	ø40.0/70.0	ø1.57/2.76	223PA6MSNB228211LG00
							sq 60.0	sq 2.36	223PA6MSNB228211LG00M060S
38	156.4	6.16	157.4	6.20	75.0	2.95	19.1/40.0*	0.75/1.57*	223PA6MSNB238211N00
							sq 38.1	sq 1.50	223PA6MSNB238211N00I150S
							sq 40.0	sq 1.57	223PA6MSNB238211N00M040S
					100.0	3.94	ø40.0/70.0*	ø1.57/2.76	223PA6MSNB238211N01

* Minimum/maximum round bore.

Placement of Wearstrips and Sprockets

No. of teeth	Minimum B-dimension		Wearstrip distance A	
	mm	in.	mm	in.
10	25.2	0.99	15.4	0.61
19	43.5	1.71	34.2	1.35
28	62.0	2.44	52.8	2.08
38	82.4	3.24	73.8	2.89

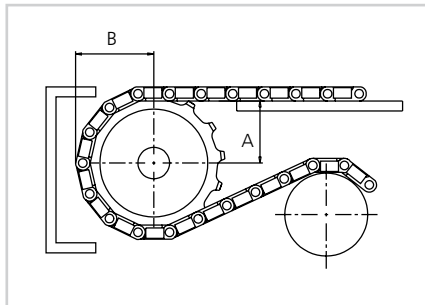

Other sprocket sizes are available upon request. Two-part sprockets are available upon request.

Max. Load per Sprocket

Belt material	POM		PP	
	N	lbf	N	lbf
uni M-QNB	1000	225	800	180

Pitch 12.7 mm (0.50 in.)



uni M-SNB M3 – strong small pitched belt

The uni M-SNB M3 is developed for tight transfer, high speed and low profile conveyors in both food and non food industries. The 0.5 in. pitch, bi-directional belt ensures product stability even in nosebar and high speed applications thanks to the rounded bottom surface.

The uni M-SNB M3 belt increases performance in the following industries/applications:

- Bakery applications including general conveyance, cooling lines, metal detectors and packaging lines
- Meat applications including tray pack lines and metal detectors
- Seafood applications including sorting lines and weighing scales
- Beverage applications including depalletizers and accumulation tables
- Can manufacturing applications including palletizers, mass handling, transfer conveyors, discharge conveyors and accumulation tables

Product features and operational benefits:

- Less vibration in high speed and nosebar applications
- Wear resistance in high speed applications with tight transfers
- Strong bi-directional belt for longer conveyors
- Unique lockpin locking system for easy maintenance
- Unique sprocket engagement reducing pulsation
- Open (flat) top surface increasing product stability and reducing backline pressure

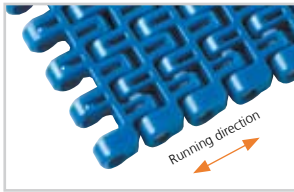
Standard Selection

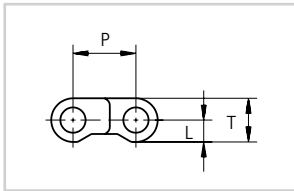
uni M-SNB M3
 Surface opening 14%

Dimensional Sketch

uni M-SNB M3
Dimensions

	mm	in.
L	4.4	0.17
P	12.7	0.50
T	8.8	0.35

Standard Materials and Colors

Type	Standard materials and colors	Standard pin materials and colors
uni M-SNB M3	POM-D B	PA6.6 D
	POM-LF BR	PA6.6 D
	PP W	PA6.6 N
	PE N	PA6.6 N

- Straight running
- 12.7 mm (0.50 in.)
- \varnothing 5 mm (0.20 in.)
- Patent** Patented
- Materials** See page 11
- 20 mm (0.8 in.)
- See page 35
- See page 171
- 01** **N** See page 16

Alternatives

- PE** **W**
- PA6.6** **B** **SS304**
- PA6.6** **N**
- PP** **B** **W**

Standard Bricklaid Belt Widths (See next page for Single Link® widths)

mm	in.	mm	in.	mm	in.	mm	in.	mm	in.
76	3.0	685	27.0	1294	50.9	1902	74.9	2510	98.8
152	6.0	762	30.0	1370	53.9	1978	77.9	2586	101.8
228	9.0	837	33.0	1446	56.9	2054	80.9	2662	104.8
304	12.0	914	36.0	1522	59.9	2130	83.9	2738	107.8
381	15.0	990	39.0	1598	62.9	2206	86.9	2814	110.8
456	18.0	1066	42.0	1674	65.9	2282	89.8	2890	113.8
533	21.0	1142	45.0	1750	68.9	2358	92.8	2966	116.8
608	23.9	1218	48.0	1826	71.9	2434	95.8	3042	119.8

On above belt width values, the belt width tolerance on standard materials is +0/-0.4% at 23°C/73°F.

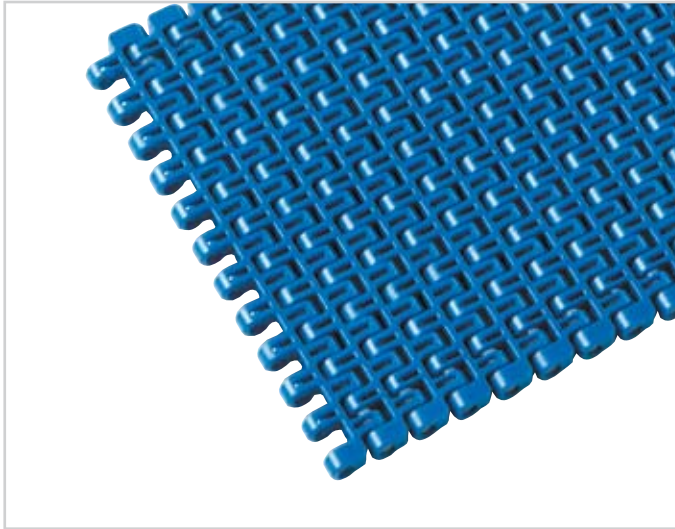
uni M-SNB M3 Single Link®

uni M-SNB M3 Single Link® is available in the following standard widths:

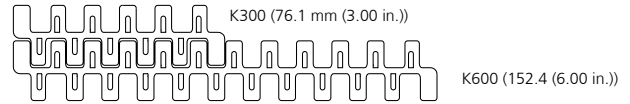
Belt Weights

Belt material	POM				PP				PE			
	plastic		steel		plastic		steel		plastic		steel	
Pin material	kg/m ²	lb/ft ²	kg/m ²	lb/ft ²	kg/m ²	lb/ft ²	kg/m ²	lb/ft ²	kg/m ²	lb/ft ²	kg/m ²	lb/ft ²
uni M-SNB M3	6.3	1.29	8.6	1.76	4.1	0.84	5.6	1.15	4.4	0.90	5.9	1.21

Permissible Tensile Strength

Belt material	POM		PP		PE	
	N/m	lbf/ft	N/m	lbf/ft	N/m	lbf/ft
uni M-SNB M3	15000	1028	7500	514	4500	308

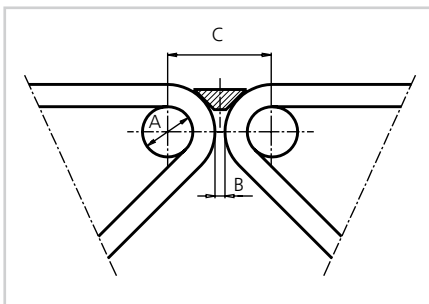
Nosebars

Min. Dimensions

	mm	in.
A min.	20.0	0.79
B min.	4.0	0.16
C min.	41.6	1.64

Standard Selection Accessories

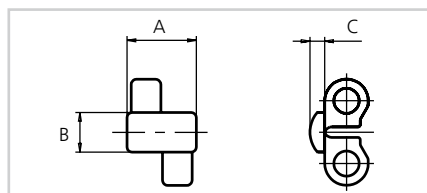
uni M-SNB M3 Rubber Inserts

Dimensional Sketch

uni M-SNB M3 Rubber Inserts

Dimensions

	mm	in.
A	14.0	0.55
B	8.0	0.31
C	3.0	0.12

Standard Material and Color:

 01 N
Rubber inserts can be assembled in any belt surface upon customer request.

Standard Sprockets

No. of teeth	Pitch diameter		Overall diameter		Hub diameter		Bore		Reference no. plastic
	mm	in.	mm	in.	mm	in.	mm	in.	
10	41.8	1.65	41.5	1.63	28.0	1.10	ø10/18.0*	0.39/0.71*	223PA6MSNB210211N00
19	78.5	3.09	79.0	3.11	65.0	2.56	19.1/40.0*	0.75/1.57*	223PA6MSNB219211LG00
							sq 25.4	sq 1.00	223PA6MSNB219211N00I100S
							sq 38.1	sq 1.50	223PA6MSNB219211N00I150S
							sq 40.0	sq 1.57	223PA6MSNB219211N00M040S
28	115.4	4.54	116.2	4.57	65.0	2.56	ø19.1/40.0	0.75/1.57*	223PA6MSNB228211LG00
							sq 38.1	sq 1.50	223PA6MSNB228211N00I150S
							sq 40.0	sq 1.57	223PA6MSNB228211LG00M040S
					100.0	3.94	ø40.0/70.0	ø1.57/2.76	223PA6MSNB228211LG00
							sq 60.0	sq 2.36	223PA6MSNB228211LG00M060S
36	156.4	6.16	157.4	6.20	75.0	2.95	19.1/40.0*	0.75/1.57*	223PA6MSNB238211N00
							sq 38.1	sq 1.50	223PA6MSNB238211N00I150S
							sq 40.0	sq 1.57	223PA6MSNB238211N00M040S
					100.0	3.94	ø40.0/70.0*	ø1.57/2.76	223PA6MSNB238211N01

* Minimum/maximum round bore.

Placement of Wearstrips and Sprockets

No. of teeth	Minimum B-dimension		Wearstrip distance A	
	mm	in.	mm	in.
10	25.2	0.99	15.4	0.61
19	43.5	1.71	34.2	1.35
28	62.0	2.44	52.8	2.08
38	82.4	3.24	73.8	2.89

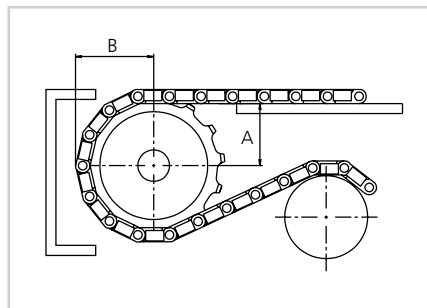

Other sprocket sizes are available upon request. Two-part sprockets are available upon request.

Max. Load per Sprocket

Belt material	POM		PP	
	N	lbf	N	lbf
uni M-SNB M3	1000	225	800	180

Pitch 19.05 mm (0.75 in.)



uni Light – unique belt for light duty applications

The uni Light belt is designed for applications with high volume production, accumulation and requirements for a smooth transfer between conveyors.

The uni Light belts have increased performance in the following industries/applications:

- Paper/tissue applications including diverters, accumulation tables and wrapping applications
- Beverage applications including depalletizers, palletizers, accumulation tables and acceleration lines
- Can manufacturing applications including palletizers, mass handling and accumulation tables
- Material handling applications
- Fruit & vegetable applications including inspection tables, elevators and incline conveyors
- Bakery applications including cooling lines, dough handling and tray conveyors

Product features and operational benefits:

- Small pitch for high speed and small transfer applications
- Easy maintenance and less downtime with unique lockpin locking system
- Unique openings for high performance (e.g. 10% opening for cherries with stems)
- Flat surface for high stability (e.g. raw edge can manufacturing)
- High friction Rubber Top for diverters or incline conveyors

Standard Selection



uni Light C



uni Light 10%



uni Light 22%



uni Light Rough Rubber Top
Indent is 15.0 mm (0.59 in.)

Dimensional Sketches

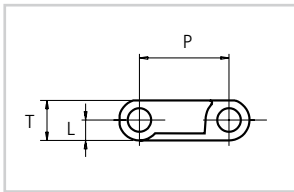

uni Light C | uni Light 10%
uni Light 22%

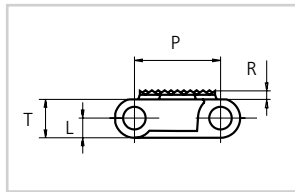

uni Light Rough Rubber Top

Dimensions

	mm	in.
A	2.0	0.08
L	4.3	0.17
P	19.1	0.75
T	8.5	0.33

- Straight running
- 19.05 mm (0.75 in.)
- ø5 mm (0.20 in.)
- Patented
- See page 11
- 25 mm (1.0 in.)
uni Light Rib:
50 mm (2.0 in.)
- See page 39
- See page 171
- 03 **K** See page 16

Alternatives

- PP** **W** **PE** **W** **GR** **N**
PA6.6 **N** **B** **SS304**

Accessories

- See page 40
- See page 41
- See page 40

Standard Materials and Colors

Type	Standard materials and colors	Standard pin materials and colors	Standard lock materials and colors
uni Light C	POM-LF BR	PA6.6 D	
	PP W	PA6.6 N	
	PP G K B	PA6.6 D	
	PA6 K	GR N	PP W G
uni Light 10%	POM-LF BR	PA6.6 D	
uni Light 22%	POM-LF BR	PA6.6 D	
	PP G	PA6.6 D	
uni Light Rough Rubber Top	PP K + 03 K	PA6.6 D	

Standard Bricklaid Belt Widths (See below for Single Link® widths)

mm	in.	mm	in.	mm	in.	mm	in.
76	3.0	840	33.1	1604	63.2	2369	93.3
153	6.0	917	36.1	1681	66.2	2445	96.3
229	9.0	993	39.1	1757	69.2	2522	99.3
306	12.0	1070	42.1	1834	72.2	2598	102.3
382	15.0	1146	45.1	1910	75.2	2674	105.3
458	18.0	1223	48.1	1987	78.2	2751	108.3
535	21.1	1299	51.1	2063	81.2	2827	111.3
611	24.1	1375	54.1	2139	84.2	2904	114.3
687	27.0	1451	57.1	2216	87.2	2980	117.3
764	30.1	1528	60.2	2292	90.2	3057	120.4

On above belt width values, the belt width tolerance on standard materials is +0/-0.4% at 23°C/73°F.

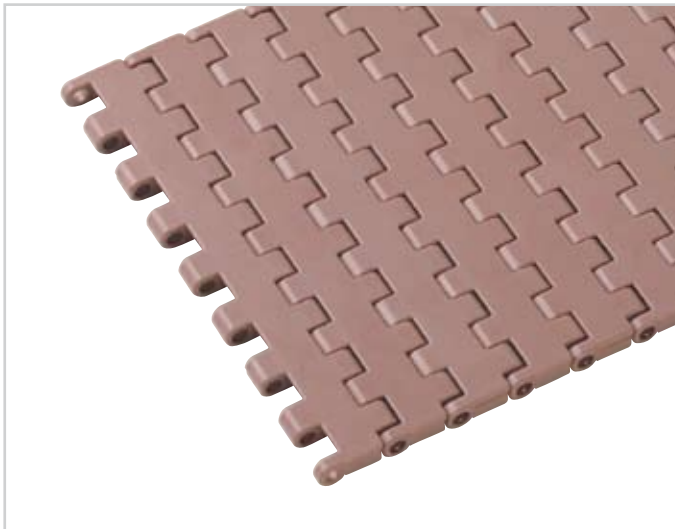
uni Light Single Link®

uni Light Single Link® is available in the following standard widths:

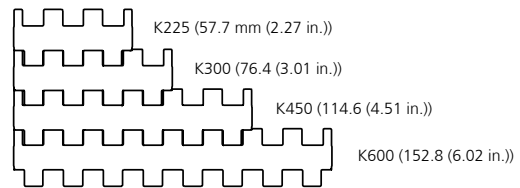
uni Light Single Link® Belt Widths

Belt type and widths	K225 57.7 mm (2.27 in.)	K300 76.4 mm (3.01 in.)	K450 114.6 mm (4.51 in.)	K600 152.8 mm (6.02 in.)
uni Light C	X	X	X	X
uni Light 10%		X		X
uni Light 22%		X		X
uni Light Rough Rubber Top				X

Standard Sprockets

No. of teeth	Pitch diameter		Overall diameter		Hub diameter		Bore		Reference no. plastic
	mm	in.	mm	in.	mm	in.	mm	in.	
7	43.9	1.73	42.6	1.68	30.0	1.18	ø16/20*	0.63/0.79*	283PA6UL07211N00
10	61.7	2.43	61.7	2.43	45.0	1.77	ø16/35*	0.63/1.38*	283PA6UL10211LG00
					49.0	1.93	hex 38.1	hex 1.50	283PA6UL10211N00I150H
17	103.7	4.08	105.0	4.13	70.0	2.76	ø19.1/40.0	0.75/1.57*	283PA6UL17211N00
							sq 40.0	sq 1.57	283PA6UL17211N00M040S
24	146.0	5.75	147.3	5.80	70.0	2.76	19.1/40.0*	0.75/1.57*	283PA6UL24211N00
							sq 38.1	sq 1.50	283PA6UL24211N00I150S
							sq 40.0	sq 1.57	283PA6UL24211N00M040S
							100.0	3.94	ø40/70*
25	152.0	5.98	153.3	6.04	70.0	2.76	19.1/40.0*	0.75/1.57*	283PA6UL24211N00
							sq 38.1	sq 1.50	283PA6UL25211N00I150S
							sq 40.0	sq 1.57	283PA6UL25211N00M040S
							100.0	3.94	ø40/70*

* Minimum/maximum round bore.

Placement of Wearstrips and Sprockets

No. of teeth	Minimum B-dimension		Wearstrip distance A	
	mm	in.	mm	in.
7	26.3	1.04	15.4	0.61
10	35.2	1.39	25.0	0.98
17	56.2	2.21	46.6	1.83
24	77.3	3.04	67.0	2.64
25	80.3	3.16	71.0	2.80

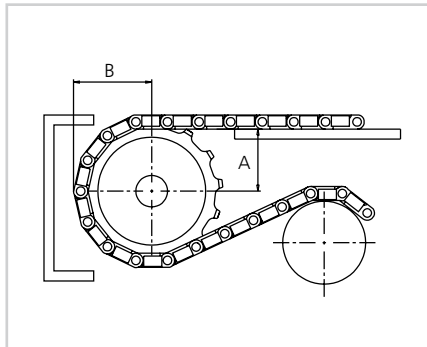

Other sprocket sizes are available upon request. Two-part sprockets are available upon request.

Max. Load per Sprocket

Belt material	POM		PP	
	N	lbf	N	lbf
uni Light	1250	281	700	157

Belt Weights

Belt material	POM				PP				PE			
	plastic		steel		plastic		steel		plastic		steel	
	kg/m ²	lb/ft ²	kg/m ²	lb/ft ²	kg/m ²	lb/ft ²	kg/m ²	lb/ft ²	kg/m ²	lb/ft ²	kg/m ²	lb/ft ²
uni Light C	6.8	1.39	14.2	2.91	4.8	0.98	12.2	2.50	4.9	1.00	12.4	2.54
uni Light 10%	6.2	1.27	13.7	2.81	4.3	0.88	11.9	2.44	4.6	0.94	12.1	2.48
uni Light 22%	5.5	1.13	13.0	2.66	3.9	0.80	11.5	2.36	4.1	0.84	11.6	2.38
uni Light Rough Rub. Top	-	-	-	-	5.5	1.13	13.0	2.66	-	-	-	-

Permissible Tensile Strength

Belt material	POM		PP		PE	
	N/m	lbf/ft	N/m	lbf/ft	N/m	lbf/ft
uni Light C	10250	702	5125	351	3075	211
uni Light Rough Rub. Top	15000	1028	5125	351	-	-

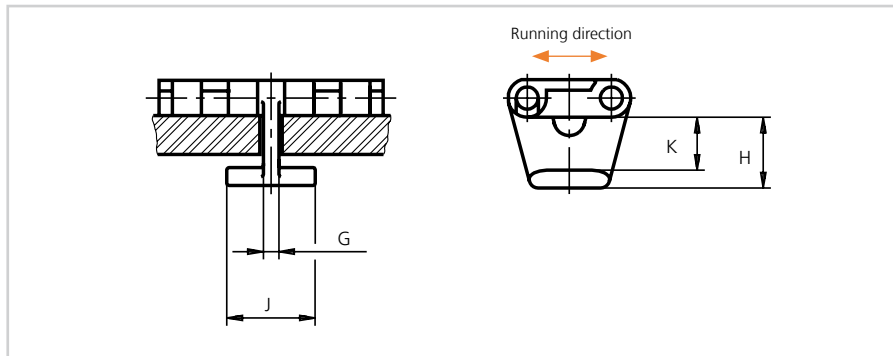
Accessories | Tab

Dimensions

	mm	in.
G	3.5	0.14
H	15.9	0.63
J	20.0	0.79
K	11.7	0.46

Please note that the tabs are not always placed in the middle of the belt.

uni Light Tab

Standard Material and Color: POM-D W

Note: When using tabs, please verify sufficient clearance to the shaft.
 Max. shaft diameter = Sprocket pitch diameter - 44.5 mm (1.75 in.). When using square shafts please verify that the diagonal does exceed above max. diameter.
 Example: Sprocket z = 17: Max. shaft diameter 103.7 - 44.5 = ø59 mm (4.08 - 1.75 = ø2.3 in.).

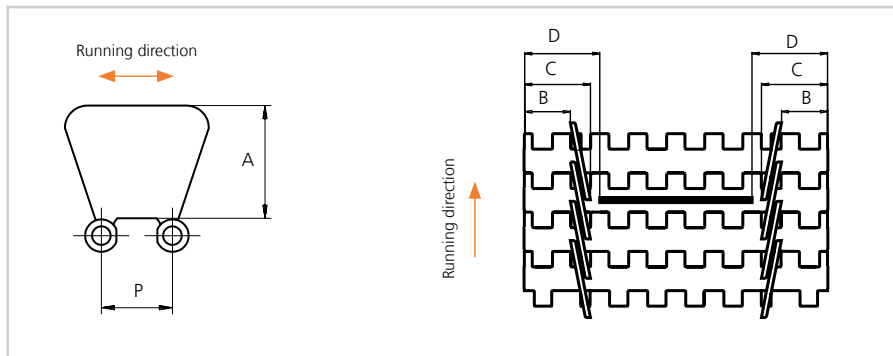
Accessories | Side Guard

Dimensions

	mm	in.
A	31.4	1.24
B*	15.0	0.59
C*	24.0	0.94
D*	25.0	0.98
P	19.05	0.75

* Increment: 9.5 mm (0.37 in.).

uni Light Tab

Standard Material and Color: PP-I W G

Accessories | Product Support

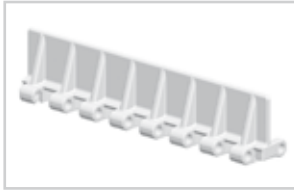

uni Light Product Support with Ribs

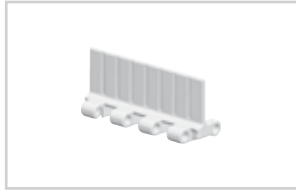

uni Light Product Support Flat (no Ribs)

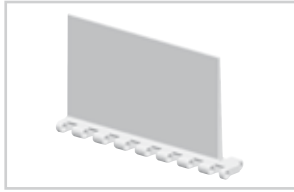

uni Light Product Support with Indent

Product Support **L-I15** (Left Indent)
Product Support **R-I15** (Right Indent)

Dimensional Sketch

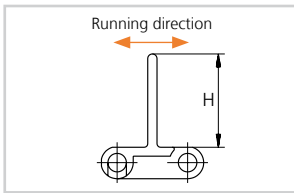

uni Light Product Support

Standard Materials, Colors and Dimensions

Style	H		Width			Molded indent			Standard materials and colors			
	mm	in.	Type	mm	in.	Type	mm	in.	PP-I	PA6	Rubber 04	
Flat (no Ribs)	25.4	1.00	K300	76.4	3.01	no*	-	-	W			
						no*	-	-	W	G	K	K
			K600	152.8	6.02	left	15.0	0.59	W	G	K	
						right	15.0	0.59	W	G	K	
with Ribs			K600	152.8	6.02	no*	-	-	W			
with Ribs	50.8	2.00	K600	152.8	6.02	no*	-	-	W	G	K	
						left	15.0	0.59	G		K	
						right	15.0	0.59	G		K	
with Ribs	76.2	3.00	K600	152.8	6.02	no*	-	-	W	G		K
						left	15.0	0.59	W	G		
						right	15.0	0.59	W	G		

* Minimum bricklaid indent for uni Light product support is 38.1 mm (1.50 in.). Increment: 19.1 mm (0.75 in.).

Pitch 25.4 mm (1.00 in.)



uni S-MPB – strong and cleanable 1 in. pitch belt

The uni S-MPB belt is a strong and cleanable belt used in various food applications. The reinforcement bar on the underside ensures high impact resistance. The uni S-MPB belt is available in the unique uni Single Link® belt with a (no bricklay) uni Single Link® product support for optimal cleaning. Nonstick version ensure product release from the belt.

The uni S-MPB belt is the preferred belt in the following industries/applications:

- Meat applications (beef & pork) including fat/trim lines, cutting lines, general conveyance, tray conveying and packaging lines
- Fruit & vegetable applications including elevators, inspection tables and packaging lines
- Seafood applications including inspection tables, grading lines and trim lines
- Bakery applications including raw dough handling, cooling lines and packing lines

Product features and operational benefits:

- Easy to clean uni Single Link® belt reducing downtime for cleaning with up to 70%
- uni Single Link® belt (no bricklay) reducing bacteria growth
- uni Single Link® eliminating knives sticking in belt seams
- Unique lockpin system providing faster and simpler maintenance
- Unique sprocket engagement enabling high product load and longer conveyors
- Strong and thick uni Single Link® product supports eliminating gaps for product traps
- Close transfer applications

Standard Selection

uni S-MPB C

uni S-MPB N

uni S-MPB NE
 Indent is 38.6 mm (1.52 in.)

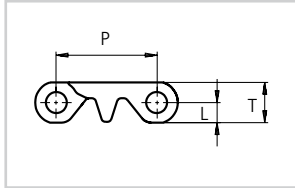
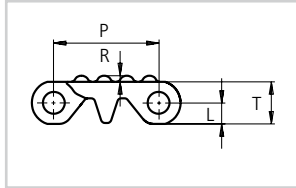
Dimensional Sketches

uni S-MPB C

uni S-MPB N | uni S-MPB NE
Dimensions

	mm	in.
L	5.2	0.21
P	25.4	1.00
R	1.5	0.06
T	10.4	0.41

- Straight running
- 25.4 mm (1.00 in.)
- \varnothing 5 mm (0.20 in.)
- Patent pending
- See page 11
- 23 mm (0.91 in.)
- See page 45
- See page 171

Accessories

- See page 44

Standard Materials and Colors

Type	Standard materials and colors	Standard pin materials and colors
uni S-MPB C	POM-DI W	PA6.6 N
	PP W B	PA6.6 N
	PE-I N B	PA6.6 N
uni S-MPB N uni S-MPB NE	POM-DI W	PA6.6 N
	PP-I W B	PA6.6 N
	PE-I N B	PA6.6 N

Standard Bricklaid Belt Widths (See next page for Single Link® widths)

mm	in.	mm	in.	mm	in.	mm	in.	mm	in.
76	3.0	684	26.9	1291	50.8	1898	74.7	2506	98.7
152	6.0	759	29.9	1367	53.8	1974	77.7	2582	101.7
228	9.0	835	32.9	1443	56.8	2050	80.7	2658	104.6
304	12.0	911	35.9	1519	59.8	2126	83.7	2734	107.6
380	15.0	987	38.8	1595	62.8	2202	86.7	2810	110.6
456	18.0	1063	41.8	1671	65.8	2278	89.7	2885	113.6
532	20.9	1139	44.8	1747	68.8	2354	92.7	2961	116.6
608	23.9	1215	47.8	1823	71.8	2430	95.7	3037	119.6

On above belt width values, the belt width tolerance on standard materials is +0/-0.4% at 23°C/73°F.

uni S-MPB Link®

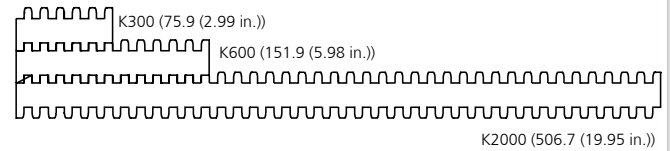

uni S-MPB Single Link® is available in the following standard widths:

uni S-MPB Single Link® Belt Widths

Belt type and widths	K300 75.9 mm (2.99 in.)	K600 151.9 mm (5.98 in.)	K2000 506.7 mm (19.95 in.)
uni S-MPB C	X	X	X
uni S-MPB N		X	
uni S-MPB NE			X

Belt Weights

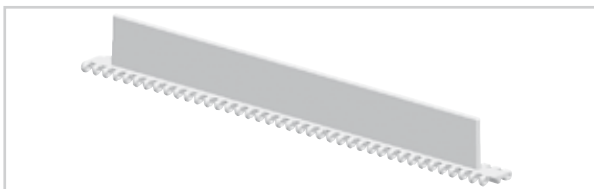
Belt material	POM		PP		PE	
Pin material	PA6.6		PA6.6		PA6.6	
	kg/m ²	lb/ft ²	kg/m ²	lb/ft ²	kg/m ²	lb/ft ²
uni S-MPB C N NE	8.3	1.69	5.6	1.14	5.7	1.18

Accessoires | Product Support

uni S-MPB Product Support

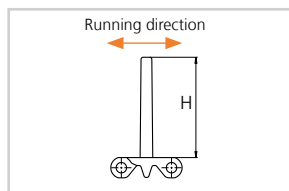
Dimensional Sketch

uni S-MPB Product Support

Standard Materials, Colors and Dimensions

Style	H		Width			Indent both sides		Standard materials & colors		
	mm	in.	Type	mm	in.	mm	in.	POM-D	PP-I	PE-I
Indent	50.8	2.00	K2000	506.7	19.95	25.8	1.02	W	W B	N B

Permissible Tensile Strength

Belt material	POM		PP		PE	
	N/m	lbf/ft	N/m	lbf/ft	N/m	lbf/ft
uni S-MPB C N NE	23500	1610	9500	651	7850	538

Standard Bi-directional Sprockets

No. of teeth	Pitch diameter		Overall diameter		Hub diameter		Bore		Reference no. plastic
	mm	in.	mm	in.	mm	in.	mm	in.	
6	50.8	2.00	48.8	1.92	33.0	1.30	ø16.0/25.4*	ø0.63/1.00*	783PA6SMPB06221N00
8	66.4	2.61	65.6	2.58	50.0	1.97	ø16.0/40.0*	ø0.63/1.57*	783PA6SMPB08221N00
10	82.2	3.24	82.2	3.24	66.0	2.60	ø18.0/40.0*	ø0.71/1.57*	783PA6SMPB10221N00
12	98.1	3.86	98.6	3.88	70.0	2.76	ø18.0/40.0*	ø0.71/1.57*	783PA6SMPB12221LG00
15	122.2	4.81	123.1	4.85	70.0	2.76	ø18.0/40.0*	ø0.71/1.57*	783PA6SMPB15221N00
							sq 38.1	sq 1.50	783PA6SMPB15221N00I150S
							sq 40.0	sq 1.57	783PA6SMPB15221N00M040S
20	162.4	6.39	163.8	6.45	70.0	2.76	ø18.0/40.0*	ø0.71/1.57*	783PA6SMPB20221N00
							sq 40.0	sq 1.57	783PA6SMPB20221N00M040S

* Minimum/maximum round bore.

Placement of Wearstrips and Sprockets

No. of teeth	Minimum B-dimension		Wearstrip distance A	
	mm	in.	mm	in.
6	30.8	1.21	16.9	0.67
8	38.5	1.52	25.6	1.01
10	46.4	1.83	34.0	1.34
12	54.4	2.14	42.3	1.67
15	66.4	2.61	54.6	2.15
20	86.5	3.41	75.1	2.96

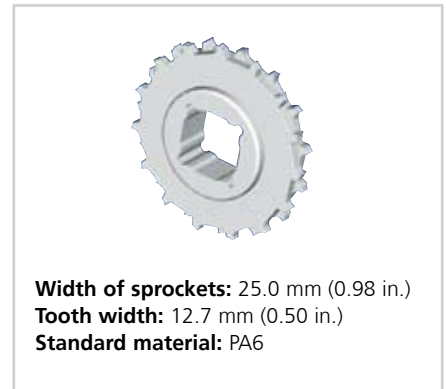
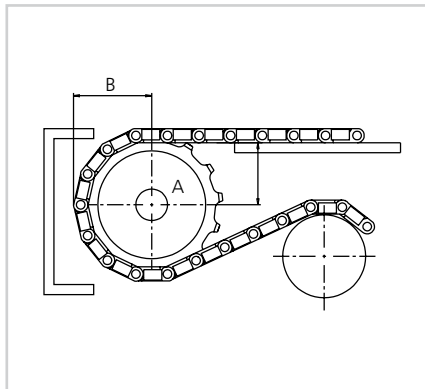

Other sprocket sizes are available upon request. Two-part sprockets are available upon request.

Max. Load per Sprocket

Belt material	POM		PP		PE	
	N	lbf	N	lbf	N	lbf
uni S-MPB	1100	247	500	112	500	112

Pitch 25.4 mm (1.00 in.)



uni QNB – strong and reliable

The uni QNB is developed with focus on optimizing strength, rigidity and wear life. The belt is unique thanks to its strength and reliability. The chamfered edges provide easy side transfer and eliminate catch points.

The uni QNB belt has increased performance in the following industries/applications:

- Bakery applications including pan handling and incline/decline box or pan applications
- Meat or poultry applications including packaging lines and incline box conveyors
- Beverage applications including depalletizers, accumulation tables and incline case conveyors
- Can manufacturing applications including palletizers, mass handling and accumulation tables
- Corrugated applications including downstacker, corrugator take off, transfer car and WIP storage
- Tire applications including wigwag, extruder takeaway and inspection applications
- Material handling applications including incline applications, palletizers and packaging lines

Product features and operational benefits:

- Strong, bi-directional belt for long conveyors
- Rough Top non-slip surface for increased worker safety
- Unique locking system for easy maintenance
- Unique sprocket engagement reducing pulsation and increasing load capacity
- Unique Rubber Top eliminating wear and increasing friction properties on incline/decline applications

Standard Selection



uni QNB C



uni QNB Rough



uni QNB Rubber Top

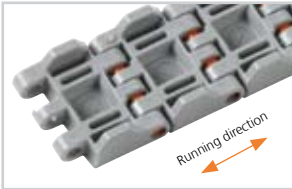

uni QNB C TAB 150



uni QNB C TAB 200

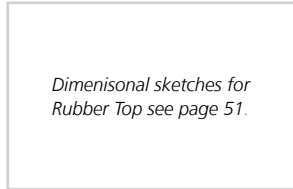

Dimensional Sketches

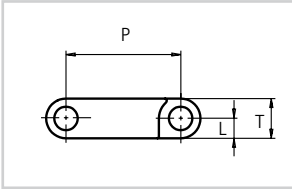

uni QNB C

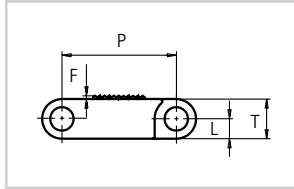

uni QNB Rough

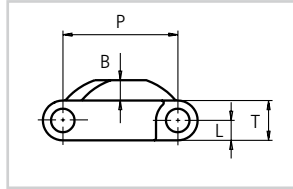

uni QNB Rubber Top

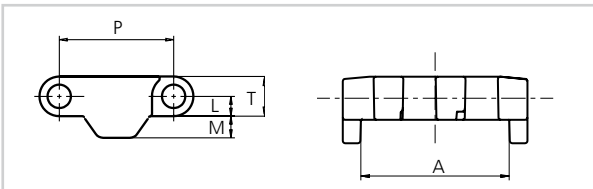

uni QNB C TAB 150

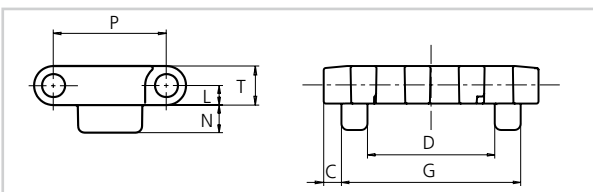

uni QNB C TAB K200

Dimensions

	mm	in.		mm	in.		mm	in.
A	30.3	1.19	F	0.8	0.03	N	6.2	0.24
B	4.5	0.18	G	42.1	1.66	P	25.4	1.00
C	4.2	0.17	L	4.4	0.17	T	8.8	0.35
D	29.9	1.18	M	4.8	0.19	-	-	-

- Straight running
- 25.4 mm (1.00 in.)
- \varnothing 5 mm (0.20 in.)
- Patent pending
- See page 11
- 40 mm (1.6 in.)
- See page 50
- See page 171
- 03 K** See page 16

Alternative

- PP** **W** **PE** **W**
PA6.6 **B** **SS304**
- PA6.6** **N**
- PA6.6** **D**
- PP** **D**

Accessories

- See page 51

Standard Materials and Colors

Type	Standard materials and colors		Standard pin materials and colors
uni QNB C	POM-SLF	B	PA6.6 D
	PP	G	PA6.6 D
uni QNB C TAB K150 uni QNB C TAB K200	POM-SLF	B	PA6.6 D
	PP	G	PA6.6 D
uni QNB Rough	POM-SLF	B	PA6.6 D
uni QNB Rubber Top	PP	G B + 03 K	PA6.6 D

Standard Bricklaid Belt Widths (See below for Single Link® widths)

mm	in.	mm	in.	mm	in.	mm	in.	mm	in.	mm	in.	mm	in.
38	1.5	379	14.9	835	32.9	1290	50.8	1746	68.7	2201	86.7	2657	104.6
51	2.0	455	17.9	911	35.9	1366	53.8	1822	71.7	2277	89.6	2732	107.6
76	3.0	531	20.9	987	38.8	1442	56.8	1898	74.7	2353	92.6	2808	110.6
152	6.0	607	23.9	1063	41.8	1518	59.8	1973	77.7	2429	95.6	2884	113.6
228	9.0	683	26.9	1139	44.8	1594	62.8	2049	80.7	2505	98.6	2960	116.5
304	12.0	759	29.9	1214	47.8	1670	65.7	2125	83.7	2581	101.6	3036	119.5

On above belt width values, the belt width tolerance on standard materials is +0/-0.4% at 23°C/73°F.

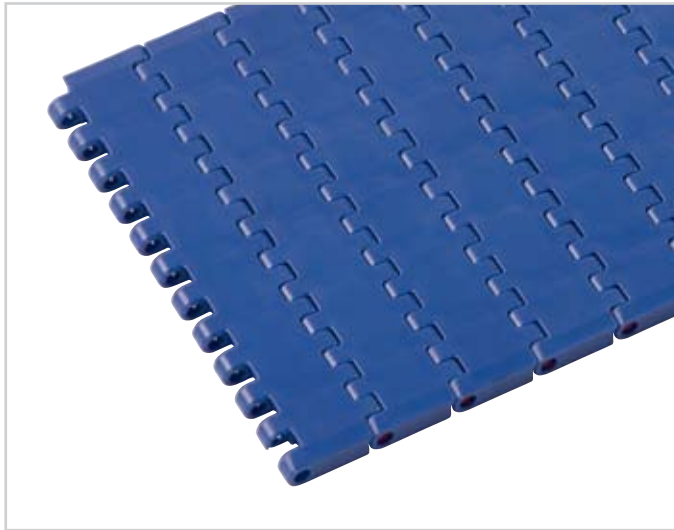
uni QNB Single Link®

uni QNB Single Link® is available in the following standard widths:

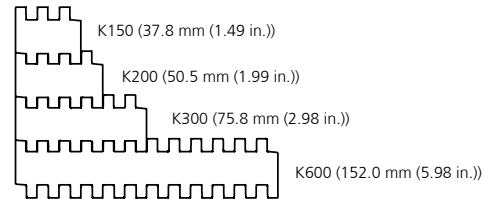
uni QNB Single Link® Belt Widths

Belt type and widths	K150 37.8 mm (1.49 in.)	K200 50.5 mm (1.99 in.)	K300 75.8 mm (2.98 in.)	K600 152.0 mm (5.98 in.)
uni QNB C	<input type="checkbox"/> SLO	<input type="checkbox"/> SLO	X	X
uni QNB C TAB	<input type="checkbox"/> SLO	<input type="checkbox"/> SLO		
uni QNB Rough			X	X
uni QNB Rubber Top			X	X

SLO = Single Link only

Belt Weights

Belt material	POM		PP	
Pin material	PA6.6		PA6.6	
	kg/m ²	lb/ft ²	kg/m ²	lb/ft ²
uni QNB C uni QNB Rough	8.4	1.72	5.4	1.11
uni QNB Rubber Top	-	-	7.0	1.43

Weights

Belt material	POM		PP	
Pin material	PA6.6		PA6.6	
	kg/m	lb/ft	kg/m	lb/ft
uni QNB C K150	0.6	0.40	0.4	0.27
uni QNB C TAB K150	0.5	0.34	0.4	0.27
uni QNB C K200	0.6	0.40	0.4	0.27
uni QNB C TAB K200	0.6	0.40	0.4	0.27

Permissible Tensile Strength

Belt material	POM		PP	
Pin material	PA6.6		PA6.6	
	N/m	lbf/ft	N/m	lbf/ft
uni QNB C uni QNB Rough	35000	2398	20000	1370
uni QNB Rubber Top	-	-	20000	1370

Permissible Tensile Strength

Belt material	POM		PP	
Pin material	PA6.6		PA6.6	
	N	lbf	N	lbf
uni QNB C uni QNB C TAB K150	1000	225	580	130
uni QNB C uni QNB C TAB K200	1500	337	860	193

Standard Sprockets

No. of teeth	Pitch diameter		Overall diameter		Hub diameter		Bore		Reference no. plastic
	mm	in.	mm	in.	mm	in.	mm	in.	
10	82.2	3.24	80.3	3.16	65.0	2.56	∅18.0/40.0*	∅0.71/1.57*	143PA6QNB10211LG00
							sq 38.1	sq 1.50	143PA6QNB10211N00I150S
							sq 40.0	sq 1.57	143PA6QNB10211LG00M040S
12	98.1	3.86	96.8	3.81	70.0	2.76	∅18.0/40.0*	∅0.71/1.57*	143PA6QNB12211LG00
							sq 38.1	sq 1.50	143PA6QNB12211N00I150S
							sq 40.0	sq 1.57	143PA6QNB12211N00M040S
15	122.2	4.81	121.5	4.78	70.0	2.76	∅18.0/40.0*	∅0.71/1.57*	143PA6QNB15211N00
							sq 38.1	sq 1.50	143PA6QNB15211N00I150S
							sq 40.0	sq 1.57	143PA6QNB15211N00M040S
					100.0	3.94	∅40.0/70.0*	∅1.57/2.76*	143PA6QNB15211N01
							sq 63.5	sq 2.50	143PA6QNB15211LG01I250S
							sq 60.0	sq 2.36	143PA6QNB15211N00M060S
18	146.3	5.76	146.1	5.75	70.0	2.76	∅18.0/40.0*	∅0.71/1.57*	143PA6QNB18211N00
							sq 38.1	sq 1.50	143PA6QNB18211N00I150S
							sq 40.0	sq 1.57	143PA6QNB18211N00M040S
					120.0	4.72	∅40.0/∅70*	∅1.57/2.76*	143PA6QNB18211N01
							sq 63.5	sq 2.50	143PA6QNB18211N00I250S
							sq 60.0	sq 2.36	143PA6QNB18211N00M060S
19	154.3	6.07	154.2	6.07	70.0	2.76	∅18.0/40.0*	∅0.71/1.57*	143PA6QNB19211N00
							sq 38.1	sq 1.50	143PA6QNB19211N00I150S
							sq 40.0	sq 1.57	143PA6QNB19211N00M040S
					120.0	4.72	∅40.0/70.0*	∅1.57/2.76*	143PA6QNB19211LG00
							sq 60.0	sq 2.36	143PA6QNB19211LG00M060S

* Minimum/maximum round bore.

Placement of Wearstrips and Sprockets

No. of teeth	Minimum B-dimension		Wearstrip distance A	
	mm	in.	mm	in.
10	45.5	1.79	34.7	1.37
12	53.5	2.11	43.0	1.69
15	65.5	2.58	55.3	2.18
18	77.5	3.05	67.6	2.66
19	81.6	3.21	71.7	2.82

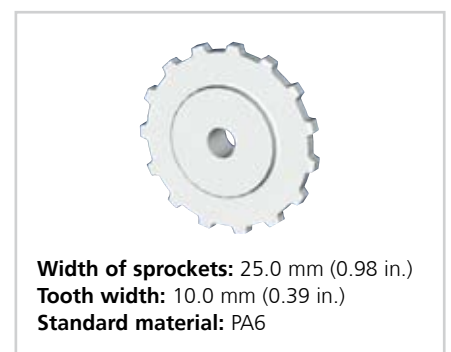
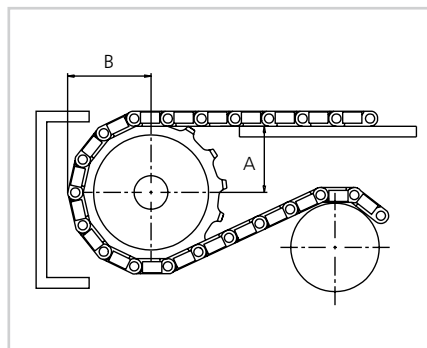

Other sprocket sizes are available upon request. Two-part sprockets are available upon request.

Max. Load per Sprocket

Belt material	POM		PP	
	N	lbf	N	lbf
uni QNB	2300	517	1300	292

Accessories | Product Support

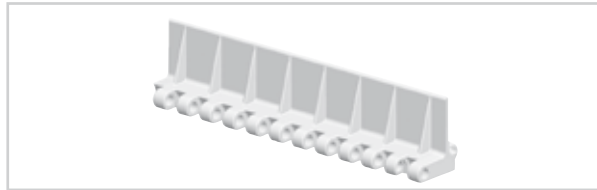

uni QNB Product Support

Dimensional Sketch

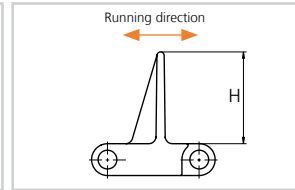

uni QNB Product Support

Minimum bricklaid indent is for uni QNB product support 25.4 mm (1.00 in.).
Increment: 25.4 mm (1.00 in.).

Standard Materials, Colors and Dimensions

H		Width			Standard materials & colors	
mm	in.	Type	mm	in.	POM-SLF	PP-I
25.4	1.00	K600	152.0	5.98	B	G

Dimensional Sketches for Rubber Top

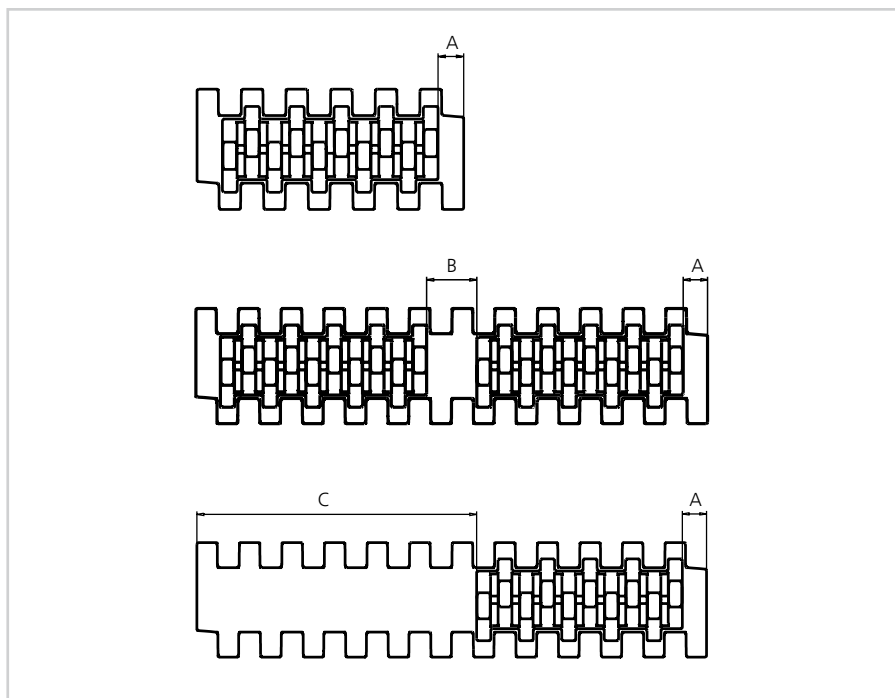

Dimensions

	mm	in.
A	7.3	0.29
B	14.9	0.58
C	83.5	3.29

Pitch 25.4 mm (1.00 in.)

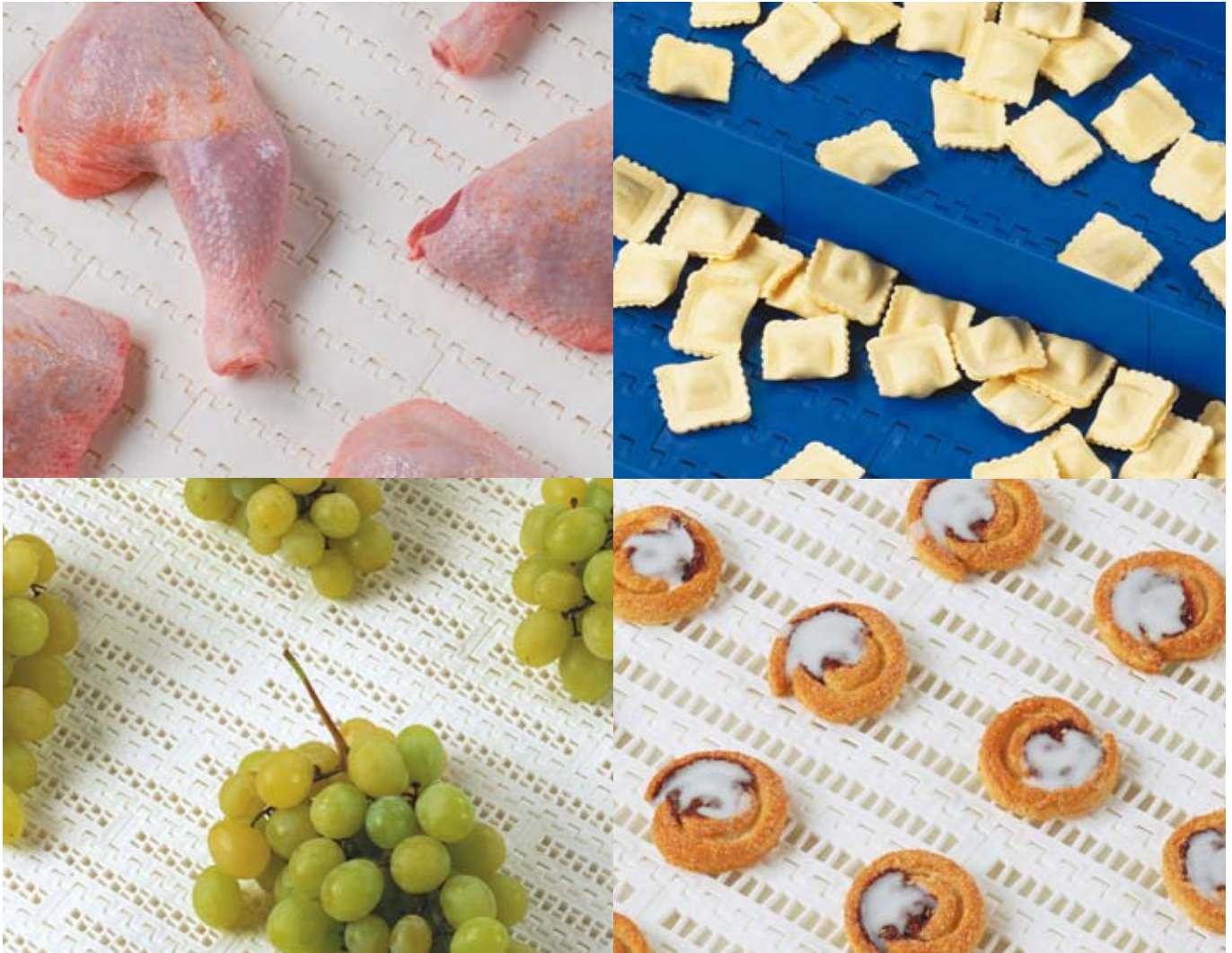

uni CNB – cleanable belt for light duty applications

The uni CNB belt is a cleanable belt for conveyance of light duty products in various food applications. The belt is available with different openings to optimize drainage and airflow and includes accessories like product supports and side guards. The unique hinge and sprocket designs increase the cleanability of the belt.

The uni CNB belt is the preferred belt in the following industries/ applications:

- Meat & poultry applications including general conveyance and breading lines
- Fruit & vegetable applications including elevators, steam peeler and inspection tables
- Seafood applications including elevators, inspection tables, grading lines, trim lines, glazing lines and cooking lines
- Bakery applications including raw dough handling, cooling lines, icing lines, packing lines and metal detectors

Product features and operational benefits:

- Easy to clean
- Unique lockpin system providing faster and simpler maintenance
- Unique sprocket engagement offering precise indexing and easy cleaning
- Different openings to optimize performance in cooling and draining applications

Standard Selection



uni CNB C



uni CNB 18%

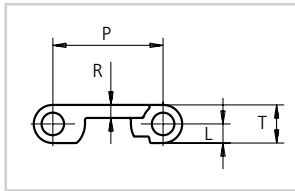

uni CNB 22%

Dimensional Sketch

 uni CNB | uni CNB 18%
uni CNB 22%

Dimensions

	mm	in.
L	4.4	0.17
P	25.4	1.00
R	3.0	0.12
T	8.8	0.35



Straight running



25.4 mm (1.00 in.)

 $\varnothing 5$ mm (0.20 in.)

Patented



See page 11

 40 mm (1.6 in.)
Side Guards 75 mm (2.95 in.)

See page 55



See page 171

Alternative

 PP **W** PE **W**
PA6.6 **B** SS304

Accessories

See page 56



See page 56

Standard Materials and Colors

Type	Standard materials and colors	Standard pin materials and colors
uni CNB C	POM-D W	PA6.6 N
	PP W	PA6.6 N
	PP B	PA6.6 N
	PE N	PA6.6 N
uni CNB 18%	PP W	PA6.6 N
uni CNB 22%	PP W	PA6.6 N
	POM-D W	PA6.6 N
	PE N	PA6.6 N

Standard Bricklaid Belt Widths (See below for Single Link® widths)

mm	in.	mm	in.	mm	in.	mm	in.	mm	in.
76	3.0	683	26.9	1290	50.8	1898	74.7	2505	98.6
152	6.0	759	29.9	1366	53.8	1973	77.7	2581	101.6
228	9.0	835	32.9	1442	56.8	2049	80.7	2657	104.6
304	12.0	911	35.9	1518	59.8	2125	83.7	2732	107.6
379	14.9	987	38.8	1594	62.8	2201	86.7	2808	110.6
455	17.9	1063	41.8	1670	65.7	2277	89.6	2884	113.6
531	20.9	1139	44.8	1746	68.7	2353	92.6	2960	116.5
607	23.9	1214	47.8	1822	71.7	2429	95.6	3036	119.5

On above belt width values, the belt width tolerance on standard materials is +0/-0.4% at 23°C/73°F.

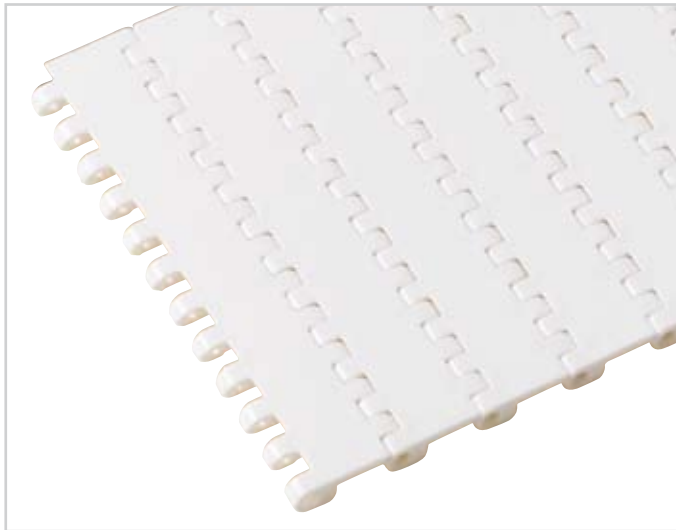
uni CNB Single Link®

uni CNB Single Link® is available in the following standard widths:

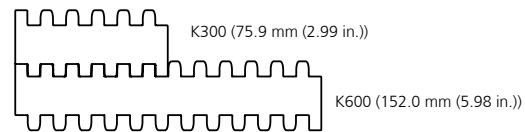
Belt Weights

Belt material	POM		PP		PE	
	plastic		plastic		plastic	
Pin material	kg/m ²	lb/ft ²	kg/m ²	lb/ft ²	kg/m ²	lb/ft ²
uni CNB C 18% 22%	5.8	1.19	3.9	0.80	4.0	0.82
uni CNB C 18% 22%	5.0	1.02	3.5	0.72	3.6	0.74
uni CNB C 18% 22%	4.8	0.98	3.4	0.70	3.5	0.72

Permissible Tensile Strength

Belt material	POM				PP				PE			
	plastic		steel		plastic		steel		plastic		steel	
Pin material	N/m	lbf/ft	N/m	lbf/ft	N/m	lbf/ft	N/m	lbf/ft	N/m	lbf/ft	N/m	lbf/ft
uni CNB C 18% 22%	13500	1925	15700	1076	7500	514	7500	514	6200	425	5800	397

Standard Sprockets

No. of teeth	Pitch diameter		Overall diameter		Hub diameter		Bore		Reference no. plastic
	mm	in.	mm	in.	mm	in.	mm	in.	
10	82.2	3.24	80.6	3.17	65.0	2.56	ø18.0/40.0*	ø0.71/1.57*	193PA6CNB10221LG00
							sq 38.1	sq 1.50	193PA6CNB10221N00I150S
							sq 40.0	sq 1.57	193PA6CNB10221N00M040S
12	98.1	3.86	96.8	3.81	70.0	2.76	ø18.0/40.0*	ø0.71/1.57*	193PA6CNB12221N00
							sq 38.1	sq 1.50	193PA6CNB12221LG00I150S
							sq 40.0	sq 1.57	193PA6CNB12221N00M040S
15	122.2	4.81	121.5	4.78	70.0	2.76	ø18.0/40.0*	ø0.71/1.57*	193PA6CNB15221LG00
							sq 38.1	sq 1.50	193PA6CNB15221N00I150S
							sq 40.0	sq 1.57	193PA6CNB15221N00M040S
18	146.3	5.76	146.1	4.72	70.0	2.76	ø18.0/40.0*	ø0.71/1.57*	193PA6CNB18221LG00
							sq 38.1	sq 1.50	193PA6CNB18221N00I150S
							sq 40.0	sq 1.57	193PA6CNB18221N00M040S
19	154.3	6.07	154.2	6.07	70.0	2.76	ø18.0/40.0*	ø0.71/1.57*	193PA6CNB19221LG00
							sq 38.1	sq 1.50	193PA6CNB19221N00I150S
							sq 40.0	sq 1.57	193PA6CNB19221N00M040S

* Minimum/maximum round bore.

Placement of Wearstrips and Sprockets

No. of teeth	Minimum B-dimension		Wearstrip distance A	
	mm	in.	mm	in.
10	45.5	1.79	34.7	1.37
12	53.5	2.11	43.0	1.69
15	65.5	2.58	55.3	2.18
18	77.5	3.05	67.6	2.66
19	81.6	3.21	71.7	2.82

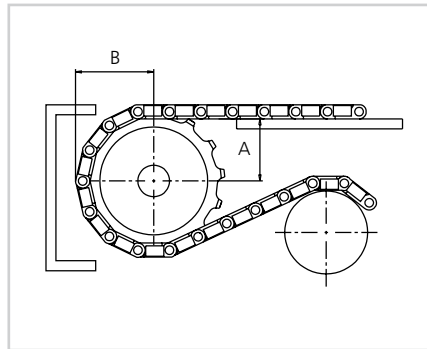

Other sprocket sizes are available upon request. Two-part sprockets are available upon request.

Max. Load per Sprocket

Belt material	POM		PP	
	N	lbf	N	lbf
uni CNB	600	135	500	112

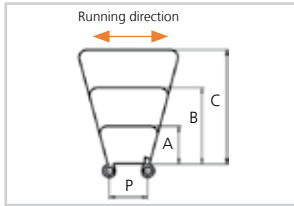
Accessories | Side Guard
Dimensional Sketch
Dimensions

	mm	in.
A	25.4	1.00
B	50.8	2.00
C	76.2	3.00
P	25.4	1.00

Minimum indent to outside of side guards: 14.0 mm (0.55 in.).
Increment: 6.4 mm (0.25 in.).

uni CNB Side Guard
Standard Material and Color:

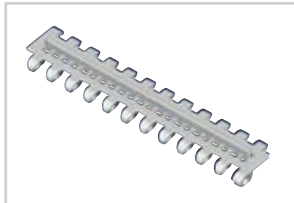
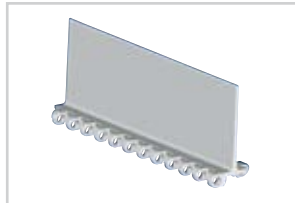
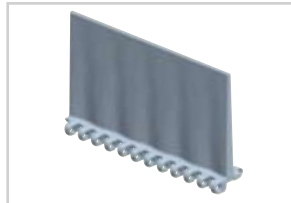
 PP-I W
Accessories | Product Support

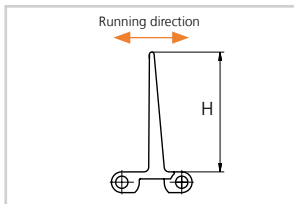
uni CNB Micro
Product Support 22%

uni CNB
Product Support, Flat

uni CNB
Product Waves (rear side of Flat)

Dimensional Sketch

uni CNB Product Support
Standard Materials, Colors and Dimensions

Style	H		Width			Molded Indent	Standard materials & colors		
	mm	in.	Type	mm	in.		POM-D	PE	PP-I
22% micro	5.0	0.20	K300	75.9	2.99	LI / RI*		N	W
			K600	152.0	5.98	LI / RI*		N	W
Flat	25.4	1.00	K600	152.0	5.98	no**	W	N	B W
Flat	50.8	2.00	K600	152.0	5.98	no**	W	N	B W
Flat	76.2	3.00	K600	152.0	5.98	no**		N	B W

* uni CNB Micro Product Support 22%: Standard indent in both sides is 6.4 mm (0.25 in.)

** Minimum bricklayered Indent for uni CNB product support is 38.1 mm (1.50 in.); 14.0 mm (0.55 in.). Increment: 12.7 mm (0.50 in.).

Pitch 25.4 mm (1.00 in.)



uni SNB M2 – the unique Open Top and Rib Top Belt

The new uni SNB M2 20% (Closed hinges) offers improved cleanability combined with high strength properties. The flat surface of the uni SNB M2 20% allows for gentle transport of sensitive products and an open surface for airflow or drainage. The uni SNB M2 belt may be used with uni SNB M2 Single Link® mold-to-width chains in de-combiners or combiners to increase conveyor speed and product throughput. The uni SNB M2 34% (Radius Top Surface) is unique in dry accumulation applications.

The uni SNB M2 belt increases performance in the following industries/applications:

- Meat applications including microwaves, cooling and freezing lines
- Fruit & vegetable applications including de-watering lines, cooling and freezing lines
- Pasta applications including blanchers, pasteurizers and cooling lines
- Beverage applications including accumulating tables, infeed to packaging, pasteurizers and palletizers
- Can manufacturing applications including accumulation tables, mass handling and palletizers

Product features and operational benefits:

- Less friction and product contact for easy cooking, cooling and freezing of products
- Radius top surface reducing back line pressure with up to 70%
- Reduced dirt and oxide build up thanks to self cleaning surface
- Unique lockpin locking system enabling easy assembly and less downtime
- Finger plates for trouble free transfer

Standard Selection



uni SNB M2 34%



uni SNB M2 34% Rib

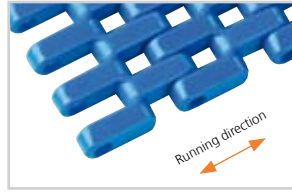

uni SNB M2 20%



uni SNB M2 20% Rubber Top

Dimensional Sketches

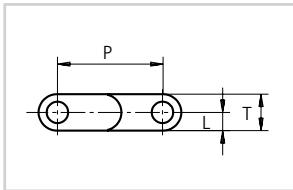

uni SNB M2 34%
uni SNB M2 20%

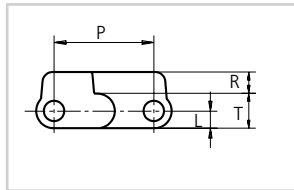

uni SNB M2 34% Rib

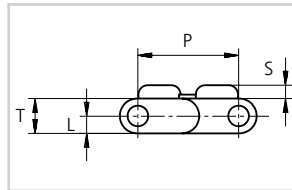

uni SNB M2 20% Rubber Top

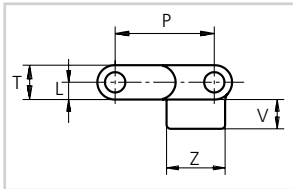

uni SNB M2 34% TAB

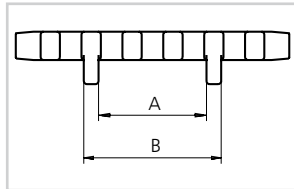

uni SNB M2 20% TAB

Dimensions

	mm	in.
A	33.5	1.19
B	42.7	1.68
L	4.4	0.17
P	25.4	1.00
T	8.8	0.35
R	5.5	0.22
S	3.4	0.13
V	7.5	0.29
Z	15.0	0.59

- Straight running
- 25.4 mm (1.00 in.)
- $\varnothing 5$ mm (0.20 in.)
- Patented
- See page 11
- 30 mm (1.2 in.)
- See page 63
- See page 171
- 03 **K** **N** See page 16

Alternative









Only for uni SNB M2 34% and uni SNB M2 34% Rib. Not 20% belt surface opening.

- PP **W** PE **W**
PA6.6 **B** SS304
- PP **B** **G** **W**

Accessories

- See page 62
- See page 61

Standard Materials and Colors

Type	Standard materials and colors	Standard pin materials and colors
uni SNB M2 34% uni SNB M2 20%	POM-D B	 PA6.6 D
	PP B G	 PA6.6 D
	PP W	 PA6.6 N
	PE N	 PA6.6 N
uni SNB M2 34% Rib	POM-SLF B	 PA6.6 D
	PP G	 PA6.6 D
uni SNB M2 20% Rubber Top	PP B G + 03 K	 PA6.6 D
	PP W + 03 N	 PA6.6 N

Standard Bricklaid Belt Widths (See next page for Single Link® widths)

mm	in.	mm	in.	mm	in.	mm	in.
76	3.0	836	32.9	1596	62.8	2356	92.8
152	6.0	912	35.9	1672	65.8	2432	95.7
228	9.0	988	38.9	1748	68.8	2508	98.7
304	12.0	1064	41.9	1824	71.8	2584	101.7
379	14.9	1140	44.9	1900	74.8	2660	104.7
456	18.0	1216	47.9	1976	77.8	2736	107.7
532	20.9	1292	50.9	2052	80.8	2812	110.7
608	23.9	1368	53.9	2128	83.8	2888	113.7
684	26.9	1444	56.8	2204	86.8	2964	116.7
760	29.9	1520	59.8	2280	89.8	3040	119.7

On above belt width values, the belt width tolerance on standard materials is +0/-0.4% at 23°C/73°F.

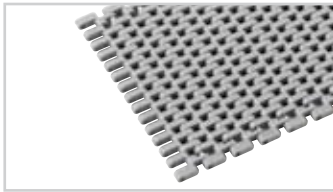
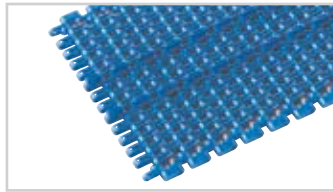
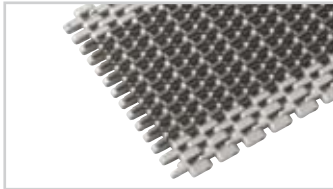
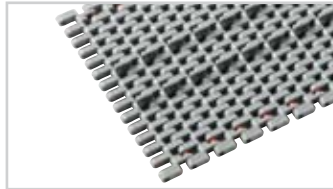
uni SNB M2 Single Link®

**uni SNB M2 20%
uni SNB 20% TAB**

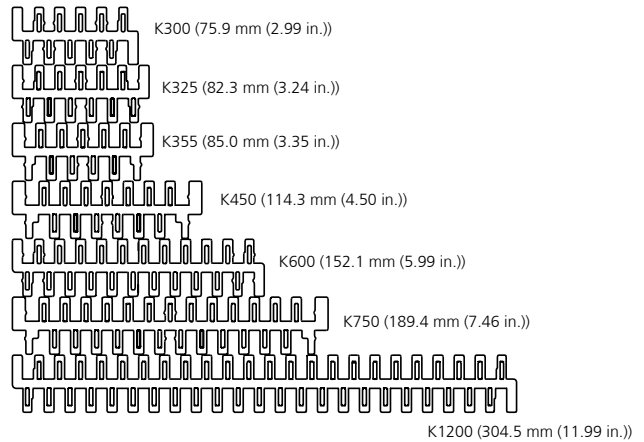
uni SNB M2 34% TAB

uni SNB M2 20% Rubber Top

uni SNB M2 20% TAB Rubber Top

uni SNB M2 Single Link® is available in the following standard widths:

Standard Materials and Colors

Type	Standard materials and colors	Standard pin materials and colors
uni SNB M2 20% uni SNB M2 20% TAB Single Link®	PP B G	PA6.6 D
uni SNB M2 20% uni SNB M2 20% TAB Rub. Top Single Link®	PP B G + 03 K	PA6.6 D
uni SNB 34% TAB Single Link®	POM-D B	PA6.6 D
	PP G	PA6.6 D

SLO = Single Link only

uni SNB M2 Single Link® Belt Widths

Belt type and widths	K300	K325	K335	K450	K600	K750	K1200
uni SNB M2 34%	X				X		X
uni SNB M2 34% TAB		SLO	SLO	SLO	SLO	SLO	
uni SNB M2 34% Rib	X				X		
uni SNB M2 20%	X				X	SLO	
uni SNB M2 20% TAB						SLO	
uni SNB M2 20% Rubber Top	X ^{1/}				X ^{1/}	SLO^{2/}	
uni SNB M2 20% TAB Rubber Top						SLO^{2/}	

SLO = Single Link only

^{1/} Indent: 7.5 mm (0.30 in.)

^{2/} Indent: 36.4 mm (1.43 in.)

Belt Weights

Belt material	POM		PP		PE	
Pin material	PA6.6		PA6.6		PA6.6	
	kg/m ²	lbf/ft ²	kg/m ²	lbf/ft ²	kg/m ²	lbf/ft ²
uni SNB M2 34%	6.3	1.29	4.3	0.88	4.4	0.90
uni SNB M2 34% Rib	8.9	1.82	5.5	1.13	-	-
uni SNB M2 20%	7.2	1.47	4.9	1.00	5.1	1.04
uni SNB M2 20% Rubber Top	-	-	5.9	1.21	-	-

Permissible Tensile Strength

Belt material	POM		PP		PE	
Pin material	PA6.6		PA6.6		PA6.6	
	N/m	lbf/ft	N/m	lbf/ft	N/m	lbf/ft
uni SNB M2 34%	23500	1610	15000	1028	10000	685
uni SNB M2 34% Rib	23500	1610	15000	1028	-	-
uni SNB M2 20%	23500	1610	15000	1028	10000	685
uni SNB M2 20% Rubber Top	-	-	15000	1028	-	-

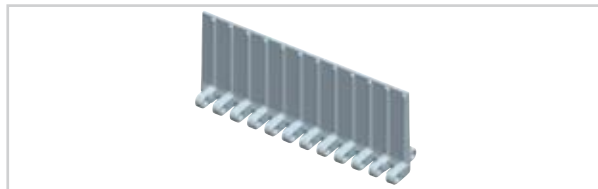
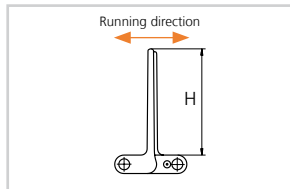
Accessories | Product Support

uni SNB M2 Product Support No Cling
Dimensional Sketch

No Cling on one side and Flat on the other side.

Minimum bricklaid Indent is for uni SNB M2 Product Support: 38.0 mm (1.50 in.).

Increment: 12.7 mm (0.50 in.).

Standard Materials, Colors and Dimensions

H		Width			Standard materials & colors		
mm	in.	Type	mm	in.	POM-D	PP	PE
25.4	1.00*	K600	152.1	5.99	B	G	N
50.8	2.00	K600	152.1	5.99	B	G	N
76.2	3.00	K600	152.1	5.99	B	G	N
101.6	4.00	K600	152.1	5.99	B	G	N

* Product Support on 1 in. (25.4 mm) are cut down from 2 in. (50.8 mm).

Accessories | Finger Plate

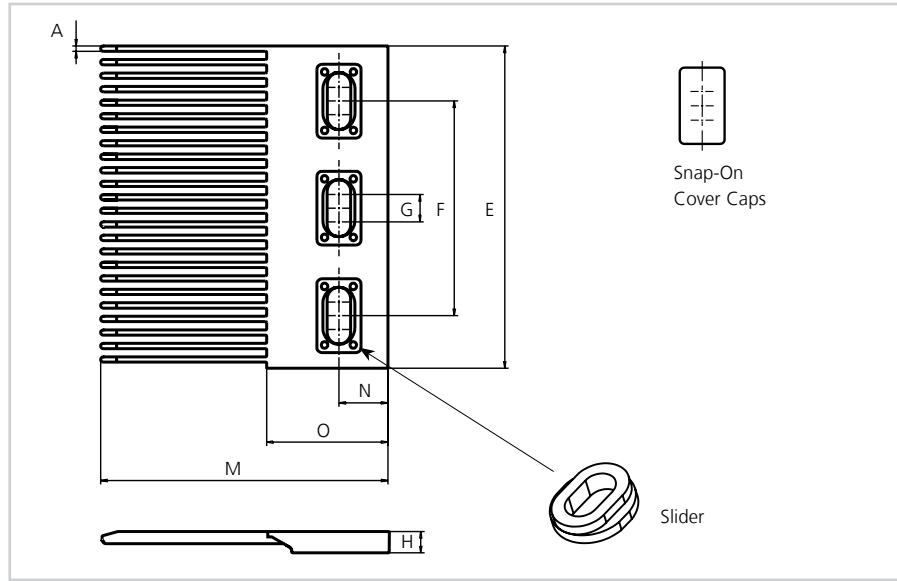

uni SNB M2 Finger Plate Type 2

Dimensions

	mm	in.
A	2.5	0.10
B	165.0	6.50
C	95.0	3.74
D	51.0	2.01
E	152.1	5.99
F	100.0	3.94
G	12.0	0.47
H	10.3	0.41
I	76.0	3.00
J	6.0	0.24
M	135.0	5.31
N	23.0	0.91
O	57.0	2.24

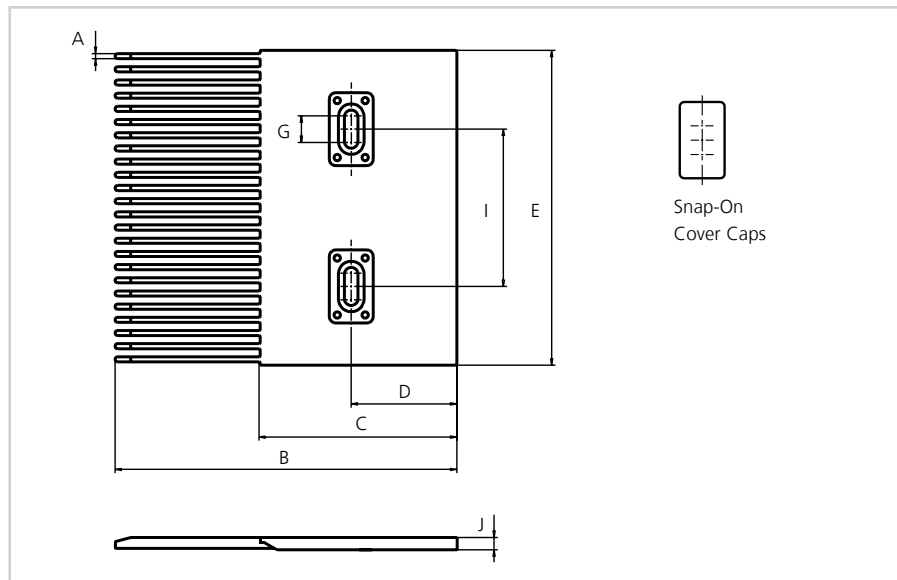

uni SNB M2 Finger Plate Type 2S

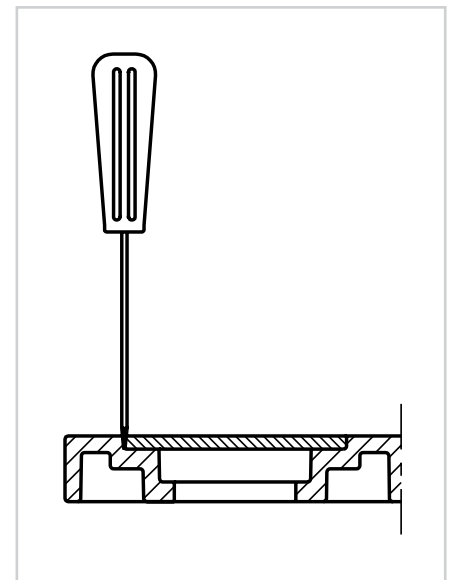

All uni-chains belt systems are available in a raised rib version can be supplied with matching finger plates, also called combs. The finger plates are supplied with cover caps which can be attached when the finger plate has been installed. The cover

caps may be removed by using a screwdriver that can be inserted between the cover and finger plates.

In order to adjust to belt width variations caused by temperature fluctuations, a slider facilitates

the sideways movement of the finger plates (finger plate type 2).

Standard Material and Color

POM-EC **K**

Only available in POM-EC black

Standard Sprockets

No. of teeth	Pitch diameter		Overall diameter		Hub diameter		Bore		Reference no. plastic
	mm	in.	mm	in.	mm	in.	mm	in.	
10	82.2	3.24	86.5	3.41	65.0	2.56	∅19.1/40.0*	∅0.75/1.57*	753PA6SNB210211LG00
							sq 38.1	sq 1.50	753PA6SNB210211LG00
							sq 40.0	sq 1.57	753PA6SNB210211N00M040S
12	98.1	3.86	103.2	4.06	65.0	2.56	∅19.1/40.0*	∅0.75/1.57*	753PA6SNB212211LG00
							sq 38.1	sq 1.50	753PA6SNB212211N00I150S
							sq 40.0	sq 1.57	753PA6SNB212211N00M040S
18	146.3	5.76	152.7	6.01	65.0	2.56	∅19.1/40.0*	∅0.75/1.57*	753PA6SNB218211LG00
							sq 38.1	sq 1.50	753PA6SNB218211N00I150S
							sq 40.0	sq 1.57	753PA6SNB218211N00M040S
					120.0	4.72	∅40.0/70.0*	∅1.57/2.76*	753PA6SNB218211N00
							sq 60.0	sq 1.57	753PA6SNB218211LG00M060S
							sq 63.5	sq 2.50	753PA6SNB218211N00I250S
19	154.3	6.07	160.9	6.33	65.0	2.56	∅19.1/40.0*	∅0.75/1.57*	753PA6SNB219211N00
							sq 38.1	sq 1.50	753PA6SNB219211LG00I150S
							sq 40.0	sq 1.57	753PA6SNB219211N00M040S
					120.0	4.72	∅40.0/70.0	∅1.57/2.76	753PA6SNB219211N01
							sq 60.0	sq 2.36	753PA6SNB219211N00M060S
20	162.4	6.39	169.1	6.66	65.0	2.56	sq 38.1	sq 1.50	753PA6SNB220211N00I150S
							sq 40.0	sq 1.57	753PA6SNB220211N00M040S
							120.0	4.72	∅40.0/70.0
					sq 63.5	sq 2.50			753PA6SNB220211N00I250S
					sq 60.0	sq 2.36			753PA6SNB220211N00M060S

* Minimum/maximum round bore.

Placement of Wearstrips and Sprockets

No. of teeth	Minimum B-dimension		Wearstrip distance A	
	mm	in.	mm	in.
10	45.5	1.79	34.7	1.37
12	53.5	2.11	43.0	1.69
18	77.6	3.06	67.6	2.66
19	81.6	3.21	71.7	2.82
20	85.6	3.37	75.8	2.98

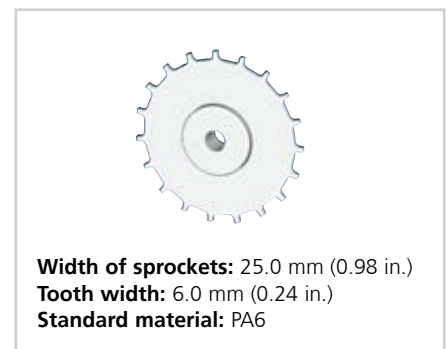
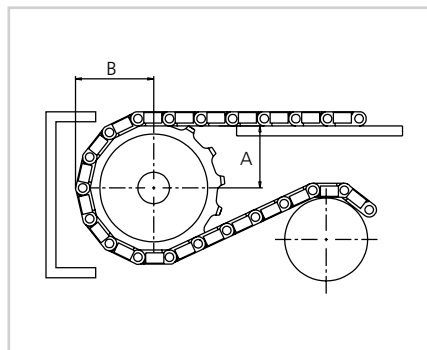

Other sprocket sizes are available upon request. Two-part sprockets are available upon request.

Max. Load per Sprocket

Belt material	POM		PP	
	N	lbf	N	lbf
uni SNB M2	1400	315	1100	247

Pitch 27.9 mm (1.10 in.)



uni OWL – the heat and wear resistant belt with minimal friction surface

uni OWL 1.1 in. pitch belt is created for applications requiring large open area.

Together with the material properties the open area belt design with minimal friction surface provides heat resistance, easy plastic film release and good airflow.

The uni OWL belt has increased performance in the following industries/applications:

- Shrinking tunnels without the need for lubrication and without black wear debris
- Bakery industries, including cooling lines
- Fruit and vegetables application including dewatering and cooling lines

Product features and operational benefits:

- Minimal friction and contact between product and belt
- Large open area for easy drainage/airflow (66% open belt)
- Special material allows operating temperature of 180°C (356°F) and makes the belt resist peak temperature up to 230°C (446°F)
- Patented nonstick belt surface

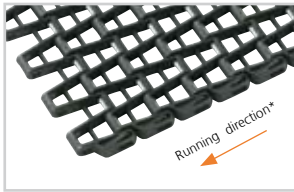
Standard Selection

uni OWL
Surface opening 66%

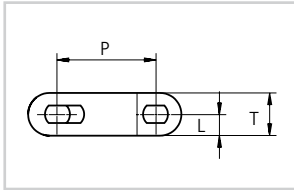
Dimensional Sketch

uni OWL

Dimensions

	mm	in.
P	27.9	1.10
L	5.5	0.22
T	11.0	0.43

** Travel in both directions is possible. Ammeraal Beltech Modular recommends this travel direction.*

- Straight running
- 27.9 mm (1.10 in.)
- $\varnothing 4.0$ mm (0.16 in.)
- See page 11
- 40 mm (1.57 in.)
- See page 67
- See page 171

Standard Materials and Colors

Type	Standard materials and colors	Standard pin materials and colors	Standard lock materials and colors
uni OWL	PA6.6 GFH K	SS304	PA6.6 GFH K
	PP G	PA6.6 B	PP G

Standard Bricklaid Belt Widths (See next page for Single Link® widths)

mm	in.	mm	in.	mm	in.	mm	in.
305	12.0	645	25.4	984	38.7	1323	52.1
339	13.3	679	26.7	1018	40.1	1357	53.4
373	14.7	713	28.1	1052	41.4	1391	54.8
407	16.0	746	29.4	1085	42.7	1425	56.1
441	17.4	780	30.7	1120	44.1	1459	57.4
475	18.7	814	32.0	1154	45.4	1493	58.8
509	20.0	848	33.4	1188	46.8	1527	60.1
525	20.7	882	34.7	1222	48.1	1561	61.5
577	22.7	916	36.1	1255	49.4	1595	62.8
611	24.1	950	37.4	1289	50.7	1629	64.1

Note: Above widths are belts in PA6.6 GFH. In PP material the belt width is 1% smaller. On above belt width values, the belt width tolerance on standard materials is +0/-0.4% at 23°C/73°F.

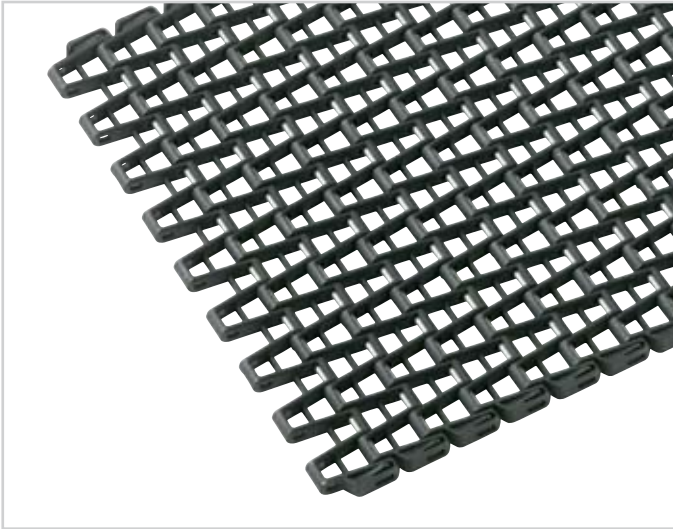
uni OWL Single Link®

uni OWL Single Link® is available in the following standard widths:

Center module are used in the middle of the belt.

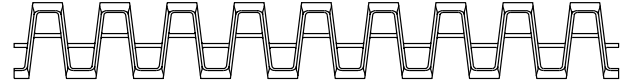
 PA6.6 GFH: K1200 (305.4 mm (12..02))
 PP: K1200 (302.5 mm (11.91))

The Both link is split in two and used as the outer part of the belt.

 PA6.6 GFH: K1200 (305.2 mm (12..02))
 PP: K1200 (302.2 mm (11.90))

uni OWL Single Link® Belt Widths

Belt type and widths	K1200 Center		K1200 Both	
	PA6.6 GFH 305.4 mm (12.02 in.)	PP 302.5 mm (11.91 in.)	PA6.6 GFH 305.2 mm (12.02 in.)	PP 302.2 mm (11.90 in.)
uni OWL	X	X	X	X

Belt Weights

Belt material	PA6.6 GFH		PP	
	SS		PA6.6	
Pin material	kg/m ²	lb/ft ²	kg/m ²	lb/ft ²
uni OWL	7.7	1.58	4.6	0.94

Permissible Tensile Strength

Belt material	PA6.6 GFH		PP	
	SS		PA6.6	
Pin material	N/m	lbf/ft	N/m	lbf/ft
uni OWL	12000	822	8000	548

Standard Sprockets

No. of teeth	Pitch diameter		Overall diameter		Hub diameter		Bore		Reference no. plastic
	mm	in.	mm	in.	mm	in.	mm	in.	
9	81.7	1.93	83.4	2.05	0	0	ø18.0/40.0	ø0.71/1.57	663PA6OWL091111N00
							sq 25.4	sq 1.00	663PA6OWL091111N00I100S
							sq 30.0	sq 1.18	663PA6OWL091111N0M030S
11	99.4	3.91	101.9	4.01	0	0	ø18.0/50.0	ø0.71/1.97	663PA6OWL111111N00
							sq 38.1	sq 1.50	663PA6OWL111111N00I150S
							sq 40.0	sq 1.57	663PA6OWL111111N00M040S
13	117.2	4.61	120.2	4.73	0	0	ø18.0/70.0	ø0.71/2.76	663PA6OWL131111N00
							sq 38.1	sq 1.50	663PA6OWL131111N00I150S
							sq 40.0	sq 1.57	663PA6OWL131111N00M040S
15	135.0	5.31	138.4	5.45	0	0	ø18.0/70.0	ø0.71/2.76	663PA6OWL151111N00
							sq 38.1	sq 1.50	663PA6OWL151111N00I150S
							sq 40.0	sq 1.57	663PA6OWL151111N00M040S
							sq 50.8	sq 2.00	663PA6OWL151111N00I200S

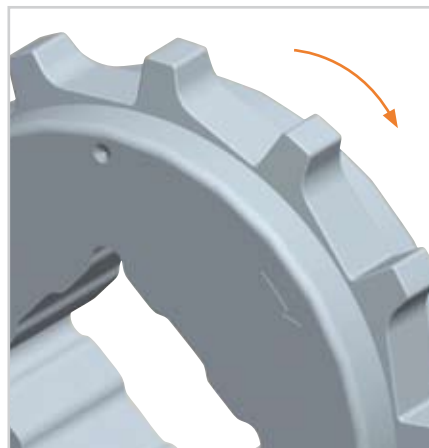

Other sprocket sizes are available upon request.

 Two-part sprockets are available upon request.

Placement of Wearstrips and Sprockets

No. of teeth	Minimum B-dimension		Wearstrip distance A	
	mm	in.	mm	in.
9	46.7	1.84	33.2	1.31
11	55.5	2.18	42.4	1.67
13	64.3	2.53	51.6	2.03
15	73.2	2.88	60.7	2.39

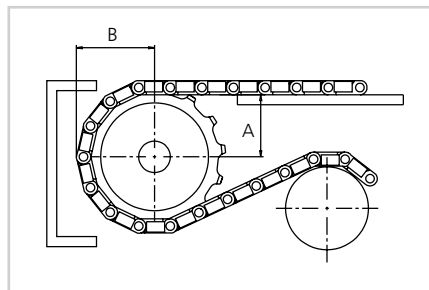
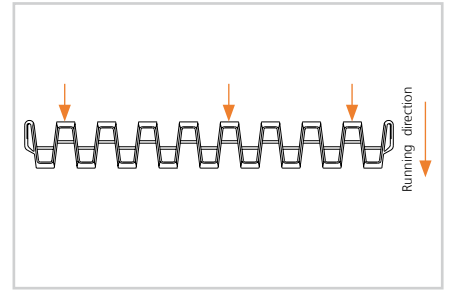
Placing of Sprockets

Max. Load per Sprocket

Belt material	PA6.6 GFH		PP	
	N	lbf	N	lbf
uni OWL	1200	270	800	180

Pitch 38.1 mm (1.50 in.)



uni SSB – strong and solid wear resistant belt

The uni SSB 1.5 in. pitch belt is created for heavy duty applications such as accumulation tables and packaging application. The uni SSB belt may be used together with uni SSB mold-to-width chains in de-combiners or combiners to increase conveyor speed and product throughput.

The uni SSB belt has increased performance in the following industries/applications:

- Fruit & vegetable applications including filling lines, canning lines, accumulation tables and incline/decline applications
- Bakery and snack food applications including cooling lines, pan handling, oven infeed and takeaway
- Beverage applications including case conveyors, denester lines, de-combiners, accumulation tables, incline/decline applications
- Can manufacturing applications including mass handling, transfer conveyors, accumulation tables, and palletizer infeed conveyors
- Material handling applications

Product features and operational benefits:

- Closed and wide hinge design increasing product stability and decreasing pin wear
- Chamfered edges allowing stability in side transfer applications
- Unique locking system preventing pins walking or pins coming out
- Unique open area for cooling conveyors and incline drainage applications

Standard Selection

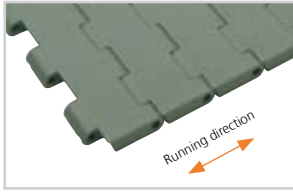

uni SSB C

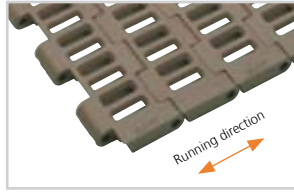

uni SSB 29%

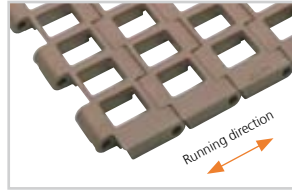

uni SSB 32%



uni SSB TAB

Dimensional Sketches

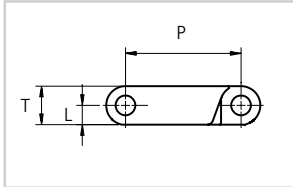

uni SSB

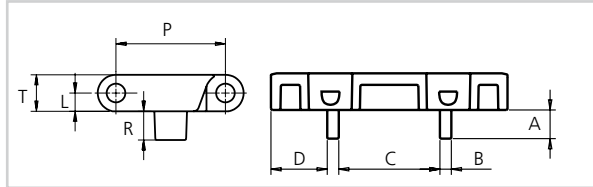

uni SSB TAB

Dimensions

	mm	in.
A	10.0	0.39
B	4.0	0.16
C	35.2	1.39
D	19.6	0.77
L	6.4	0.25
P	38.1	1.50
R	10.0	0.39
T	12.7	0.50

- Straight running
- 38.1 mm (1.50 in.)
- $\varnothing 6.35$ mm (0.25 in.)
- Materials** See page 11
- 45 mm (1.8 in.)
- See page 72
- See page 72
- See page 171

Alternative

PP **W**
SS304

Accessories

See page 71

Standard Materials and Colors

Type	Standard materials and colors	Standard pin materials and colors	Standard lock materials and colors
uni SSB C uni SSB TAB	POM-LF BR	GR N	PP B
	PP G	GR N	PP B
uni SSB 29%	POM-LF BR	GR N	PP B
	PP G	GR N	PP B
uni SSB 32%	POM-LF BR	GR N	PP B
	PP G	GR N	PP B

Standard Bricklaid Belt Widths (See below for Single Link® widths)

mm	in.	mm	in.	mm	in.	mm	in.	mm	in.
76	3.0	683	26.9	1291	50.8	1899	74.8	2507	98.7
152	6.0	759	29.9	1367	53.8	1975	77.8	2583	101.7
228	9.0	835	32.9	1443	56.8	2051	80.8	2659	104.7
304	12.0	911	35.9	1519	59.8	2127	83.7	2735	107.7
380	15.0	987	38.9	1595	62.8	2203	86.7	2811	110.7
456	18.0	1063	41.9	1671	65.8	2279	89.7	2887	113.7
532	20.9	1139	44.8	1747	68.8	2355	92.7	2963	116.7
607	23.9	1216	47.9	1823	71.8	2431	95.7	3039	119.7

On above belt width values, the belt width tolerance on standard materials is +0/-0.4% at 23°C/73°F.

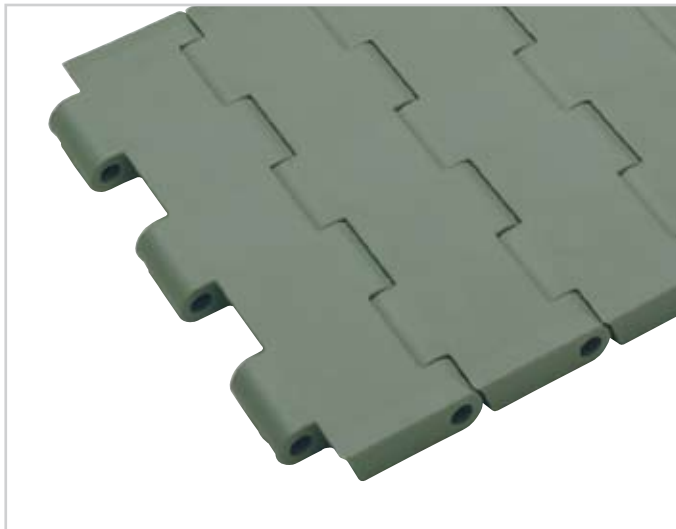
uni SSB Single Link®

uni SSB Single Link® is available in the following standard widths:

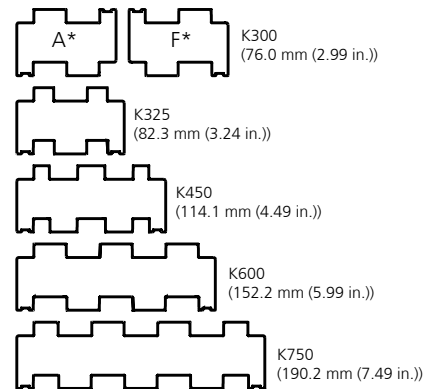

* Depending on the width, the uni SSB belt is bricklaid with two different K300 modules called "A" and "F." For belt widths that are multiples of 6 in. an "A" and modular "F" module are used on opposite sides every other pitch. For other belt widths only an "F" module is used on alternating sides every pitch.

uni SSB Single Link® Belt Widths

Belt type and widths	K300	K325	K450	K600	K750
	76.0 mm (2.99 in.)	82.3 mm (3.24 in.)	114.1 mm (4.49 in.)	152.2 mm (5.99 in.)	190.2 mm (7.49 in.)
uni SSB C	X	SLO	SLO	X	SLO
uni SSB C TAB		SLO			
uni SSB 29%	X			X	
uni SSB 32%	X			X	

SLO = Single Link only

Belt Weights

Belt material	POM						PP					
	GR		PP		steel		GR		PP		steel	
Pin material	kg/m ²	lb/ft ²	kg/m ²	lb/ft ²	kg/m ²	lb/ft ²	kg/m ²	lb/ft ²	kg/m ²	lb/ft ²	kg/m ²	lb/ft ²
uni SSB	11.3	2.31	11.1	2.27	13.6	2.79	7.4	1.52	7.2	1.47	9.9	2.03

Permissible Tensile Strength

Belt material	POM						PP					
	steel		GR		PP		steel		GR		PP	
Pin material	N/m	lbf/ft	N/m	lbf/ft	N/m	lbf/ft	N/m	lbf/ft	N/m	lbf/ft	N/m	lbf/ft
uni SSB	36000	2467	19400	1329	9300	637	18000	1233	13000	891	11000	754

Accessories | Product Support

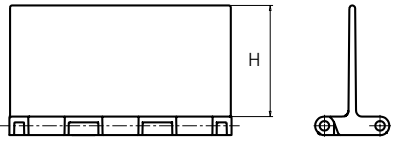

Minimum bricklaid indent is for uni SSB Product Support 50.8 mm (2.00 in.).

Increment: 25.4 mm (1.00 in.).

uni SSB Product Support
Standard Dimensions

Style	H		Width		
	mm	in.	mm		in.
Flat	76.1	3.00	K600	152.2	5.99

Standard Material and Color

PP-I	G
------	---

Standard Sprockets - Single Row

No. of teeth	Pitch diameter		Overall diameter		Hub diameter		Bore		Reference no. plastic
	mm	in.	mm	in.	mm	in.	mm	in.	
19	117.3	4.62	117.1	4.61	57.2	2.25	ø18.0/40.0*	ø0.71/1.57*	163PA6SSB19211N00
21	129.3	5.09	130.0	5.12	57.2	2.25	ø18.0/40.0*	ø0.71/1.57*	163PA6SSB21211N00
23	141.2	5.56	142.0	5.59	57.2	2.25	ø18.0/40.0*	ø0.71/1.57*	163PA6SSB23211N00
25	153.2	6.03	154.2	6.07	57.2	2.25	ø18.0/40.0*	ø0.71/1.57*	163PA6SSB25211N00

* Minimum/maximum round bore.

Placement of Wearstrips and Sprockets

No. of teeth	Minimum B-dimension*		Wearstrip distance A	
	mm	in.	mm	in.
19	65.0	2.56	49.1	1.93
21	70.9	2.79	55.4	2.18
23	76.9	3.03	61.6	2.42
25	82.9	3.26	67.8	2.67

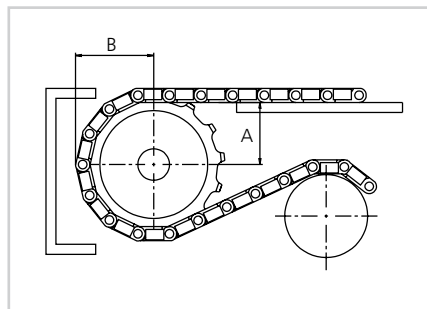

Other sprocket sizes are available upon request. Two-part sprockets available upon request.

Note: uni SSB can also be driven by uni 820 chain sprockets except uni SSB K325 and K450.

* B-dimension is for Flat Top Belt. In case of other belt configuration add height of Rib Top, Product Supports or Sideguards to B-dimension.

Standard Sprockets - Two-part Single Row

No. of teeth	Pitch diameter		Overall diameter		Hub diameter		Bore		Reference no. plastic
	mm	in.	mm	in.	mm	in.	mm	in.	
19	117.3	4.62	117.1	4.61	58.0	2.28	ø18.0/40.0*	ø0.71/1.57*	163PA6SSB19212N00
21	129.3	5.09	130.0	5.12	58.0	2.28	ø18.0/40.0*	ø0.71/1.57*	163PA6SSB21212N00
23	141.2	5.56	142.0	5.59	58.0	2.28	ø18.0/40.0*	ø0.71/1.57*	163PA6SSB23212N00
25	153.2	6.03	154.2	6.07	58.0	2.28	ø18.0/40.0*	ø0.71/1.57*	163PA6SSB25212N00

* Minimum/maximum round bore.

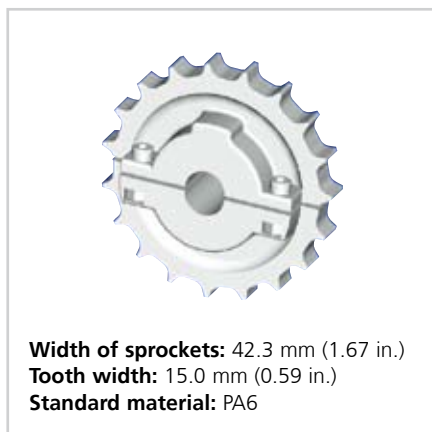

Standard Sprockets - Double Row

No. of teeth	Pitch diameter		Bore min.		Bore max.		Reference no. plastic
	mm	in.	mm	in.	mm	in.	
19	117.3	4.62	20.0	0.79	40.0	1.57	303382019N
21	129.2	5.09	20.0	0.79	40.0	1.57	303382021N
23	141.2	5.56	20.0	0.79	40.0	1.57	303382023N
25	153.2	6.03	20.0	0.79	40.0	1.57	303382025N
27	165.2	6.50	20.0	0.79	40.0	1.57	303382027N
29	177.2	6.98	20.0	0.79	40.0	1.57	303382029N
31	189.3	7.45	20.0	0.79	40.0	1.57	303382031N

Bore and keyway available upon request.

Placement of Wearstrips and Sprockets

No. of teeth	Minimum B-dimension*		Wearstrip distance A	
	mm	in.	mm	in.
19	65.0	2.56	49.1	1.93
21	70.9	2.79	55.4	2.18
23	76.9	3.03	61.6	2.42
25	82.9	3.26	67.8	2.67
27	88.9	3.50	74.0	2.91
29	94.9	3.74	80.1	3.16
31	100.9	3.97	86.3	3.40

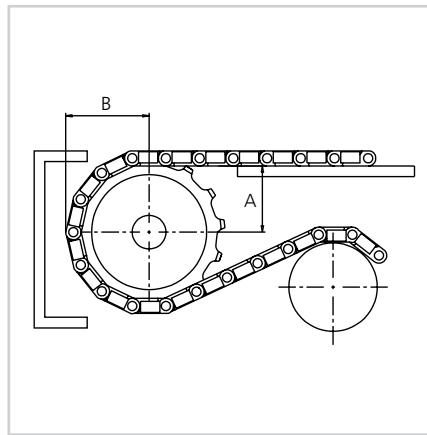
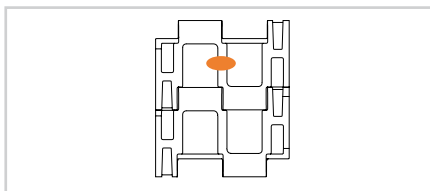
Overview Sprocket Placement

uni SSB K300

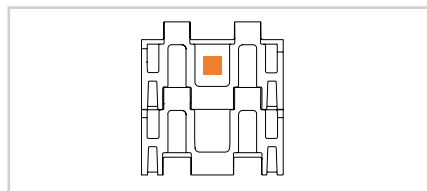
SLO & bricklaid

uni SSB K325

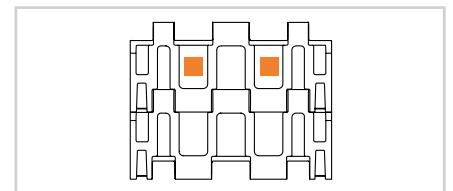
SLO

uni SSB K450

SLO

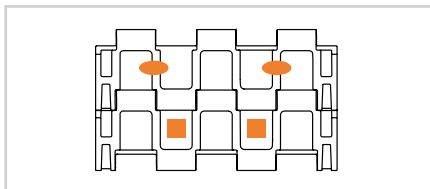
uni SSB K600

SLO & bricklaid

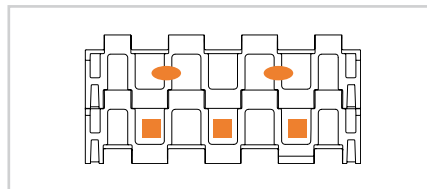
uni SSB K750

SLO

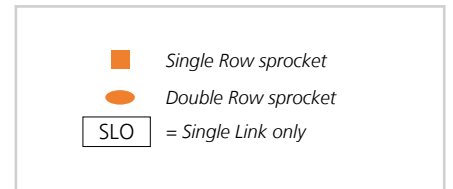
Max. Load per Sprocket

Belt material	POM		PP	
	N	lbf	N	lbf
uni SSB	2000	450	1200	270

Pitch 38.1 mm (1.50 in.)



uni Light EP – light duty application belt

The uni Light EP 1.5 in. pitch belt is designed for light duty applications such as cooking, blanching and pasteurizing in the food industry. The different openings allow high performance with various food products.

The uni Light EP belt is commonly used in the following industries/ applications:

- Fruit & vegetable applications including elevators, blanchers, cooking lines and pasteurizers
- Pasta applications including blanchers, pasteurizers and cooling lines
- Agriculture (corn & rice) applications including elevators, blanchers and cooking lines
- Beverage applications including accumulation tables, pasteurizers and palletizers

Product features and operational benefits:

- Various openings including fine-mesh for water drainage and filtering
- Steel reinforcement feature eliminating belt elongation in high temperature applications
- Reinforced product supports for high load elevators and incline conveyors

Standard Selection



uni Light EP
22% fine-meshed



uni Light EP
22% fine-meshed with
reinforcement links

*Reinforcement Link:
See page 76 for further
information.*

Dimensional Sketch

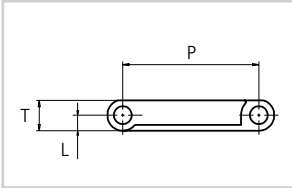

uni Light EP

Dimensions

	mm	in.
L	4.3	0.17
P	38.1	1.50
T	8.5	0.33

- Straight running
- 38.1 mm (1.50 in.)
- \varnothing 5 mm (0.20 in.)
- Patented
- See page 11
- 75 mm (3.0 in.)
- See page 77
- See page 171

Alternatives

- PE** W
- SS304**
- PP** W

Accessories

- SS316** See page 16

Standard Materials and Colors

Type	Standard materials and colors	Standard pin materials and colors	Standard lock materials and colors
uni Light EP 22% fine-meshed	PPHW W	PP W	PP W
	PPHW B	PP W	PP W

Standard Bricklaid Belt Widths (See next page for Single Link® widths)

mm	in.	mm	in.	mm	in.	mm	in.	mm	in.
102	4.0	661	26.0	1170	46.1	1678	66.1	2186	86.1
152	6.0	712	28.0	1220	48.0	1728	68.0	2236	88.0
254	10.0	763	30.0	1271	50.0	1779	70.0	2287	90.0
305	12.0	814	32.0	1322	52.0	1830	72.0	2338	92.0
355	14.0	865	34.0	1373	54.0	1881	74.1	2389	94.1
406	16.0	916	36.1	1424	56.1	1932	76.1	2440	96.1
458	18.0	966	38.0	1474	58.0	1982	78.0	-	-
509	20.0	1017	40.0	1525	60.0	2033	80.0	-	-
559	22.0	1068	42.0	1576	62.0	2084	82.0	-	-
610	24.0	1119	44.1	1627	64.1	2135	84.1	-	-

On above belt width values, the belt width tolerance on standard materials is +0/-0.4% at 23°C/73°F.

uni Light EP Single Link®

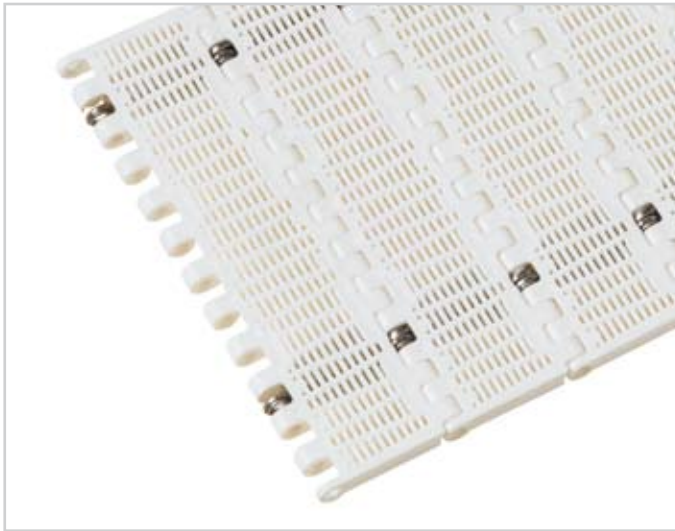

uni Light EP Single Link® is available in the following standard widths:

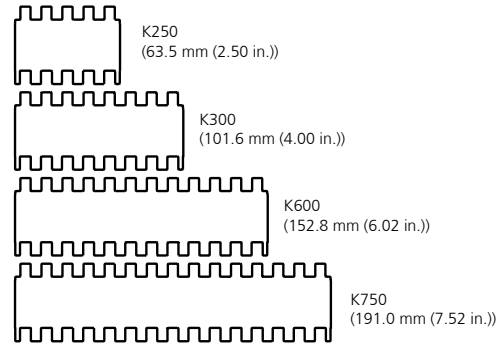

Belt Weights

Belt material	POM				PP				PE			
	plastic		steel		plastic		steel		plastic		steel	
Pin material	kg/m ²		lb/ft ²		kg/m ²		lb/ft ²		kg/m ²		lb/ft ²	
uni Light EP 22% fine-mesh.	4.8	0.98	8.4	1.72	3.4	0.70	7.0	1.43	3.6	0.74	7.2	1.48

Permissible Tensile Strength

Belt material	POM		PP		PE	
	N/m	lbf/ft	N/m	lbf/ft	N/m	lbf/ft
uni Light EP 22% fine-mesh.	10250	702	5125	351	3075	211

uni Light EP 22% Reinforcement Link



The use of uni-chains belts with the SS reinforcement /pitch control links in blanchers, cookers and other high temperature applications will reduce belt elongation due to temperature by more than 90%. This will simplify the belt take-up system and reduce maintenance.

uni-chains recommends one reinforcement link per K600 module.

Note: Reinforcement links require the use of SS pins.

Load Capacity per Reinforcement Link

	N/row	lbf/row
uni Light EP 22% fine-meshed	1000	225

Standard Sprockets

No. of teeth	Pitch diameter		Overall diameter		Hub diameter		Bore		Reference no. plastic
	mm	in.	mm	in.	mm	in.	mm	in.	
7	87.8	3.46	86.0	3.39	65.0	2.56	ø18.0/40.0*	ø0.71/1.57*	253PA6EP07211LG00
9	111.4	4.39	110.6	4.35	90.0	3.54	ø18.0/70.0*	ø0.71/2.76*	253PA6EP09211N00
							sq 38.1	sq 1.50	253PA6EP09211N00I150S
10	123.3	4.85	122.7	4.83	100.0	3.94	ø18.0/70.0*	ø0.71/2.76*	253PA6EP10211N00
							sq 38.1	sq 1.50	253PA6EP10211N00I150S
							sq 40.0	sq 1.57	253PA6EP10211N00M040S
11	135.2	5.32	134.9	5.31	110.0	4.33	ø18.0/70.0*	ø0.71/2.76*	253PA6EP11211N00
12	147.2	5.80	147.1	5.79	120.0	4.72	ø18.0/70.0*	ø0.71/2.76*	253PA6EP12211LG00
							sq 38.1	sq 1.50	253PA6EP12211N00I150S
							sq 40.0	sq 1.57	253PA6EP12211N00M040S
15	183.3	7.22	183.6	7.23	120.0	4.72	ø18.0/40.0*	ø0.71/1.57*	253PA6EP15211N00

* Minimum/maximum round bore.

Placement of Wearstrips and Sprockets

No. of teeth	Minimum B-dimension		Wearstrip distance A	
	mm	in.	mm	in.
7	48.3	1.90	35.2	1.39
9	60.0	2.36	48.0	1.89
10	66.0	2.60	54.3	2.14
11	72.0	2.83	60.5	2.38
12	78.0	3.07	66.7	2.63
15	96.0	3.78	85.3	3.36

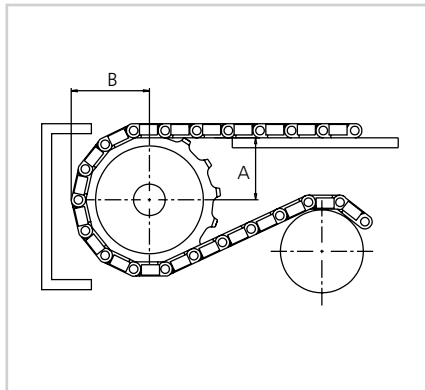

Other sprocket sizes are available upon request. Two-part sprockets are available upon request.

Max. Load per Sprocket

Belt material	POM		PP	
	N	lbf	N	lbf
uni Light EP	1000	225	600	135

Pitch 50.0 mm (1.97 in.)



uni L-SNB – the heavy duty Open Top and Rib Top belt

The uni Large SNB 2 in. pitch belt is designed for heavy duty applications in various industries. The unique surface profile limits friction and contact between products and belt and increases airflow. The uni L-SNB belt has the unique stainless steel reinforcement link feature which allows pitch control in high temperature applications.

The uni L-SNB belt increases performance in the following industries/applications:

- Meat applications including microwaves, and cooling freezing lines
- Fruit & vegetable applications including de-watering lines, cooling and lines
- Pasta applications including blanchers, pasteurizers and cooling lines
- Beverage applications including accumulating tables, pasteurizers and palletizers
- Can manufacturing applications including accumulation tables, mass handling, palletizers, battery filling and charging lines

Product features and operational benefits:

- Less friction and product contact - for easy cooking, cooling of products
- Large open area for easy drainage
- Steel reinforcement feature reducing belt elongation in high temperature applications
- Easy cleaning providing less maintenance and downtime
- Finger plates for trouble free transfer
- Small backflex radius for lower profile conveyors

Standard Selection

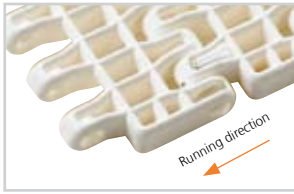

uni L-SNB
Surface opening 36%



uni L-SNB Rib
Surface opening 36%

Dimensional Sketches

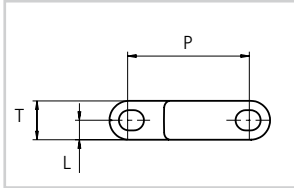

uni L-SNB

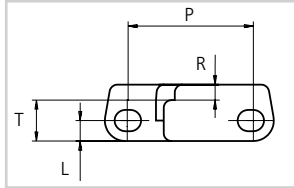

uni L-SNB Rib

Dimensions

	mm	in.
L	8.0	0.31
P	50.0	1.97
R	6.0	0.23
T	16.0	0.63

- Straight running
- 50.0 mm (1.97 in.)
- Endlock
- $\varnothing 8$ mm (0.31 in.)
- Patented
- See page 11
- 70 mm (2.8 in.)
uni L-SNB Rib: 140 mm (5.5 in.)
- See page 81
- See page 171
- Alternative**
- PE** W SS304
- Accessories**
- See page 82
- SS316** See page 16

Standard Materials and Colors

Type	Standard materials and colors	Standard pin materials and colors	Standard lock materials and colors
uni L-SNB	PP W	PP N	PP W
	PP N	PP N	PP N
uni L-SNB Rib	POM-LF BR	PP N	PP G
	PP G	PP N	PP G

Standard Bricklaid Belt Widths (See below for Single Link® widths)

mm	in.	mm	in.	mm	in.	mm	in.	mm	in.
152	6.0	760	29.9	1369	53.9	1977	77.8	2585	101.8
228	9.0	836	32.9	1445	56.9	2053	80.8	2661	104.8
304	12.0	912	35.9	1521	59.9	2129	83.8	2737	107.8
380	15.0	988	38.9	1597	62.9	2205	86.8	2813	110.7
456	18.0	1064	41.9	1673	65.9	2281	89.8	2889	113.7
532	20.9	1140	44.9	1749	68.9	2357	92.8	2965	116.7
608	23.9	1217	47.9	1825	71.9	2433	95.8	3041	119.7
684	26.9	1293	50.9	1901	74.8	2509	98.8	3117	122.7

On above belt width values, the belt width tolerance on standard materials is +0/-0.4% at 23°C/73°F.

uni L-SNB Single Link®



uni L-SNB Single Link® is available in the following standard widths:

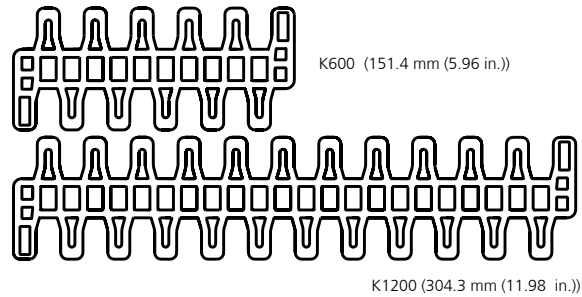

Belt Weights

Belt material	POM				PP			
	plastic		steel		plastic		steel	
Pin material	kg/m ²		lb/ft ²		kg/m ²		lb/ft ²	
uni L-SNB	10.2	2.09	17.1	3.50	6.7	1.37	13.8	2.83
uni L-SNB Rib	14.8	3.03	21.8	4.46	9.8	2.01	16.7	3.42

Permissible Tensile Strength

Belt material	POM		PP	
	N/m	lbf/ft	N/m	lbf/ft
uni L-SNB	35000	2398	17500	1199
uni L-SNB Rib	55000	3768	29800	12042

uni L-SNB Reinforcement Link



The use of uni-chains belts with the SS reinforcement /pitch control links in blanchers, cookers and other high temperature applications will reduce belt elongation due to temperature by more than 90%. This will simplify the belt take-up system and reduce maintenance.

Ammeraal Beltech Modular recommends three reinforcement links per K1200 module.

Note: Reinforcement links require the use of SS pins.

Load Capacity per Reinforcement Link

	N/row	lbf/row
uni L-SNB	2500	562

Standard Sprockets

No. of teeth	Pitch diameter		Overall diameter		Hub diameter		Bore		Reference no. plastic
	mm	in.	mm	in.	mm	in.	mm	in.	
6	100.0	3.94	92.5	3.64	70.0	2.76	ø18.0/40.0*	ø0.71/1.57*	203PA6LSNB06211LG00
8	130.7	5.15	128.6	5.06	100.0	3.94	ø18.0/40.0*	ø0.71/1.57*	203PA6LSNB08211LG00
					100.0	3.94	ø40.0/70.0*	ø1.57/2.76*	203PA6LSNB08211N01
10	161.8	6.37	159.8	6.29	70.0	2.76	ø18.0/40.0*	ø0.71/1.57*	203PA6LSNB10211LG00
					120.0	4.72	ø40.0/70.0*	ø1.57/2.76*	203PA6LSNB10211N01
12	193.2	7.61	192.5	7.58	70.0	2.76	ø18.0/40.0*	ø0.71/1.57*	203PA6LSNB12211LG00
					120.0	4.72	ø40.0/70.0*	ø1.57/2.76*	203PA6LSNB12211N01
16	256.3	10.09	257.3	10.13	200.0	7.87	ø40.0/70.0*	ø1.57/2.76*	203PA6LSNB16211N01

* Minimum/maximum round bore.

Placement of Wearstrips and Sprockets

No. of teeth	Minimum B-dimension		Wearstrip distance A	
	mm	in.	mm	in.
6	58.0	2.28	35.3	1.39
8	73.3	2.89	52.4	2.06
10	88.9	3.50	69.0	2.72
12	104.6	4.12	85.3	3.36
16	136.1	5.36	117.7	4.63

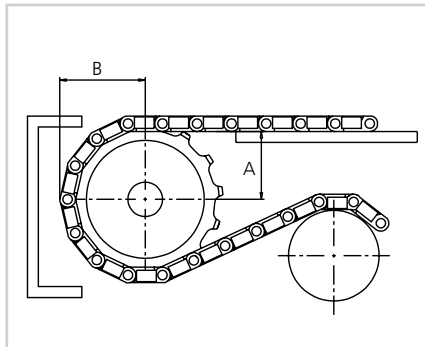

Other sprocket sizes are available upon request. Two-part sprockets are available upon request.

Max. Load per Sprocket

Belt material	POM		PP	
	N	lbf	N	lbf
uni L-SNB	4000	899	2200	496

Accessories | Finger Plates

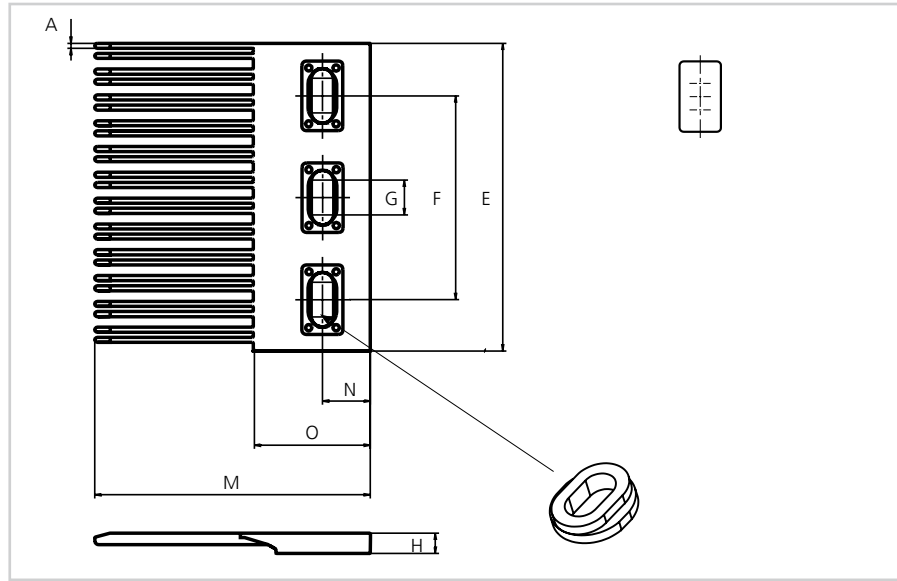

uni L-SNB Finger Plate Type A

Dimensions

	mm	in.
A	2.5	0.10
E	152.1	5.99
F	100.3	3.95
G	12.0	0.47
H	10.0	0.39
I	80.0	3.15
J	114.0	4.49
K	192.0	7.56
M	135.0	5.31
N	23.0	0.91
O	57.0	6.18

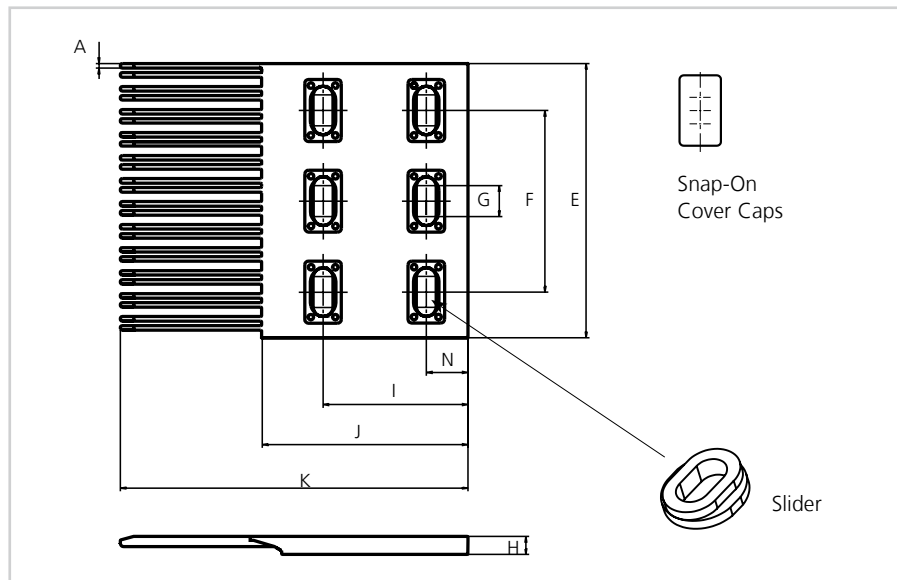

uni L-SNB Finger Plate Type B

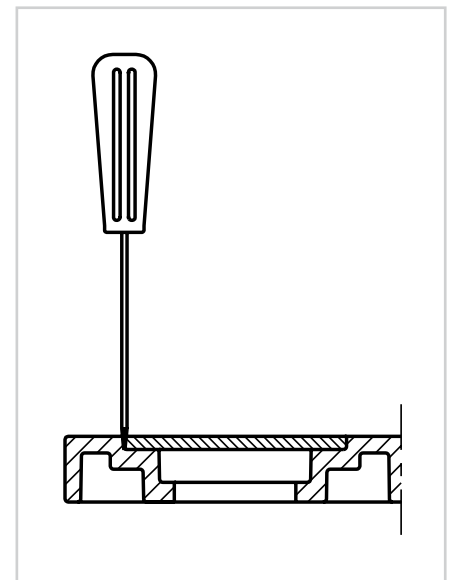

All uni-chains belt systems are available in a raised rib version that can be supplied with matching finger plates, also called combs. The finger plates are supplied

with cover caps which can be attached when the finger plate has been installed. The cover caps can be removed by using a screwdriver that can be inserted between the cover and finger

plate. In order to adjust to belt width variations caused by temperature fluctuations, a slider facilitates the sideways movement of the finger plates.

Standard Material and Color

POM-LF **BR** POM-DI **G**

Pitch 50.0 mm (1.97 in.)



uni OPB – the open belt with a unique top and bottom surface

The uni OPB 2 in. pitch belt is developed for the processes of cooking, blanching and pasteurizing in the food industry. The different openings provide high performance with various food products.

The uni OPB belt is commonly used in the following industries/ applications:

- Fruit & vegetable applications including elevators, blanchers, cooking lines and pasteurizers
- Pasta applications including blanchers, pasteurizers and cooling lines
- Agricultural applications (corn & rice) including, elevators, blanchers and cooking lines
- Beverage applications including accumulating tables, pasteurizers and palletizers

Product features and operational benefits:

- Small or large opening including fine mesh for water drainage
- Pitch control/steel reinforcement feature reduce belt elongation with up to 90% in high temperature applications
- Wear and impact resistant bottom surface
- Reinforced product supports for high load elevators and incline conveyors
- Finger plates for trouble free transfer

Standard Selection



uni OPB 4V 23%



uni OPB 4V 23%
fine-meshed



uni OPB 4V 23% Rib



uni OPB 4V 36%

* Running in both directions is possible. Ammeraal Beltech Modular recommends this travel direction.
Note: uni OPB 4V 23%, uni OPB 4V 23% Rib and uni OPB 4V 36% are listed in the USDA "Accepted Meat and Poultry Equipment" publication as accepted for food contact.

Dimensional Sketches

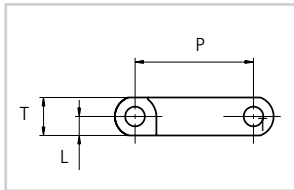

uni OPB 4V

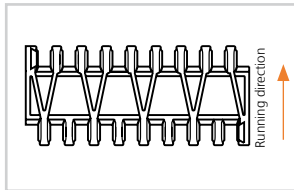

Bottom uni OPB 4V

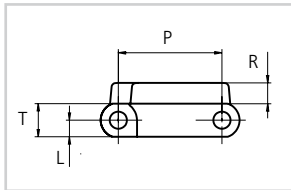

uni OPB 4V Rib

Dimensions

	mm	in.
L	8.0	0.31
P	50.0	1.97
R	10.0	0.39
T	16.0	0.63

- Straight running
- 50.0 mm (1.97 in.)
- ø8 mm (0.31 in.)
- Materials** See page 11
- Rib: 300 mm (11.8 in.)
Side Guards: 200 mm (7.9 in.)
- See page 84
- See page 171

Alternative

- PE **W** PA6.6 **N**
- PP **W** PE **W** SS304 SS316
- PP **W** G B PE **W** B
- Trilock

Accessories

- See page 88
- See page 88
- See page 89
- SS316** See page 86

Standard Materials and Colors

Type	Standard materials and colors	Standard pin materials and colors
uni OPB 4V 23%	PPHW B	PP W
uni OPB 4V 23% fine-meshed	PPHW B	PP W
uni OPB 4V 23% Rib	PP G	PP W
uni OPB 4V 36%	PE W	PP W

Standard Bricklaid Belt Widths (See below for Single Link® widths)

mm	in.	mm	in.	mm	in.	mm	in.	mm	in.
151	5.9	452	17.8	754	29.7	1055	41.5	2262	89.1
185	7.3	486	19.1	788	31.0	1206	47.5	2413	95.0
268	10.6	503	19.8	804	31.7	1357	53.4	2564	100.9
302	11.9	536	21.1	872	34.3	1508	59.4	2714	106.9
335	13.2	570	22.4	905	35.6	1659	65.3	2865	112.8
386	15.2	603	23.7	938	36.9	1810	71.2	3016	118.7
403	15.9	636	25.0	988	38.9	1960	77.2	3167	124.7
418	16.5	703	27.7	1022	40.2	2111	83.1	3318	130.6

On above belt width values, the belt width tolerance on standard materials is +0/-0.4% at 23°C/73°F.

Note: For belt widths for 23% fine-meshed, please add 0.35% to above values.

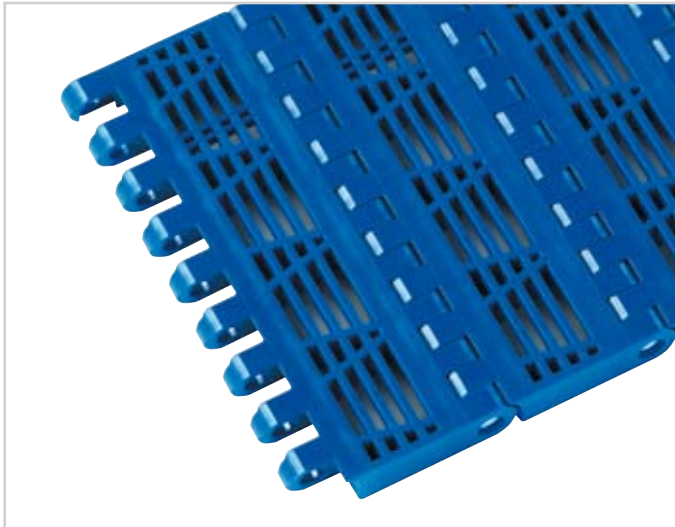
uni OPB Single Link®

uni OPB Single Link® is available in the following standard widths:

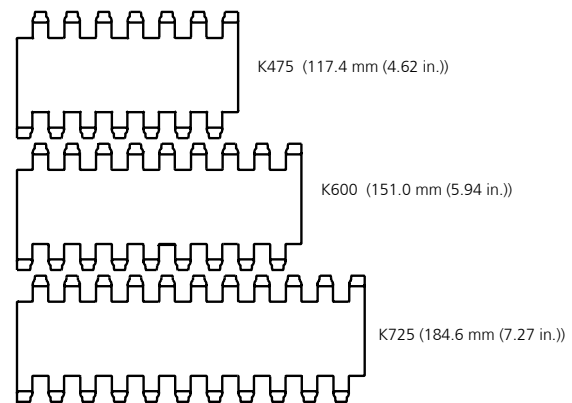
uni OPB Single Link® Belt Widths

Belt type and widths	K475 117.4 mm (4.62 in.)	K600 151.0 mm (5.94 in.)	K725 184.6 mm (7.27 in.)
uni OPB 4V 23%	X	X	X
uni OPB 4V 23% fine-meshed	X	X	X
uni OPB 4V 23% Rib		X	
uni OPB 4V 36%		X	

Belt Weights

Belt material	POM				PP			
Pin material	plastic		steel		plastic		steel	
	kg/m ²	lb/ft ²	kg/m ²	lb/ft ²	kg/m ²	lb/ft ²	kg/m ²	lb/ft ²
uni OPB 23% fine-meshed	10.1	2.07	17.0	3.48	6.8	1.39	13.7	2.81
uni OPB Rib	14.6	2.99	21.5	4.40	9.7	1.99	16.6	3.40
uni OPB 36%	9.5	1.95	14.4	3.36	6.4	1.31	13.3	2.72

Permissible Tensile Strength

Belt material	POM		PP	
	N/m	lbf/ft	N/m	lbf/ft
uni OPB 4V	22000	1507	11000	754

uni OPB Reinforcement/Pitch Control Links



The use of uni-chains belts with the SS reinforcement /pitch control links in blanchers, cookers and other high temperature applications will reduce belt elongation due to temperature by more than 90%. This will simplify the belt take-up system and reduce maintenance.

Ammeraal Beltech Modular recommends one reinforcement link per K600 module.

Note: Reinforcement links require the use of SS pins.

Load Capacity per Reinforcement Link

	N/row	lbf/row
uni OPB	2500	562

Standard Sprockets

No. of teeth	Pitch diameter		Overall diameter		Hub diameter		Bore		Reference no. plastic
	mm	in.	mm	in.	mm	in.	mm	in.	
6	100.0	3.94	94.5	3.72	65.0	2.56	ø18.0/40.0*	ø0.71/1.57*	243PA6OPBS06211N00
							sq 38.1	sq 1.50	243PA6OPBS06211N00I150S
							sq 40.0	sq 1.57	243PA6OPBS06211N00M040S
8	130.7	5.15	129.0	5.08	65.0	2.56	ø18.0/40.0*	ø0.71/1.57*	243PA6OPBS08211N00
							sq 38.1	sq 1.50	243PA6OPBS08211N00I150S
							sq 40.0	sq 1.57	243PA6OPBS08211N00M040S
10	161.8	6.37	160.1	6.30	65.0	2.56	ø18.0/40.0*	ø0.71/1.57*	243PA6OPBS10211N00
							sq 38.1	sq 1.50	243PA6OPBS10211N00I150S
							sq 40.0	sq 1.57	243PA6OPBS10211N00M040S
					120.0	4.72	ø40.0/70.0*	ø1.57/2.76*	243PA6OPBS10211N01
12	193.2	7.61	191.5	7.54	65.0	2.56	ø18.0/40.0*	ø0.71/1.57*	243PA6OPBS12211N00
							sq 38.1	sq 1.50	243PA6OPBS12211N00I150S
							sq 40.0	sq 1.57	243PA6OPBS12211N00M040S
					150.0	5.91	ø40.0/70.0*	ø1.57/2.76*	243PA6OPBS12211N01
13	208.9	8.22	207.3	8.16	72.0	2.83	ø18.0/40.0*	ø0.71/1.57*	243PA6OPBS13211N00
					150.0	5.91	sq 38.1	sq 1.50	243PA6OPBS13211N01
16	256.3	10.09	254.9	10.04	200.0	7.87	ø40.0/70.0*	ø1.57/2.76*	243PA6OPBS16211N01

* Minimum/maximum round bore.

Placement of Wearstrips and Sprockets

No. of teeth	Minimum B-dimension*		Wearstrip distance A	
	mm	in.	mm	in.
6	58.0	2.28	35.3	1.39
8	73.3	2.89	52.4	2.06
10	88.9	3.50	68.9	2.71
12	104.6	4.12	85.3	3.36
13	112.5	4.43	93.4	3.68
16	136.1	5.36	117.7	4.63



*Note B-dimension is for a Flat Top belt. In case of other belt configuration please add height of Rib-Top, Product Supports or Side guards to B-dimension.

Other sprocket sizes are available upon request. Two-part sprockets are available upon request.

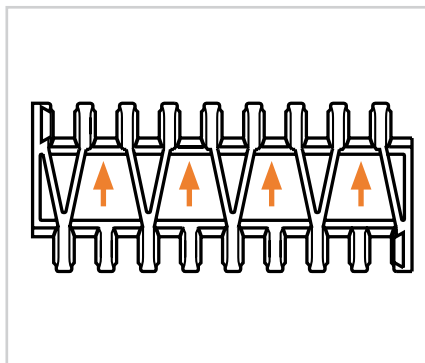
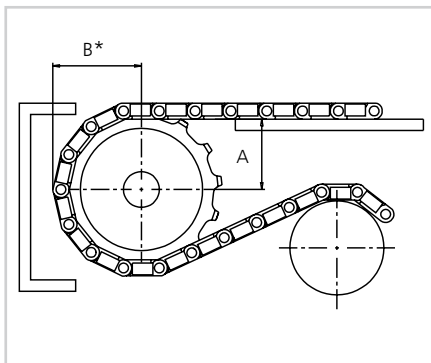
Placing of Sprockets

Max. Load per Sprocket

Belt material	POM		PP	
	N	lbf	N	lbf
uni OPB	3500	787	2000	450

Accessories | Product Support

uni OPB Product Support
No Cling

uni OPB Product Support
No Cling with Ribs

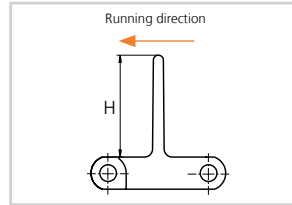
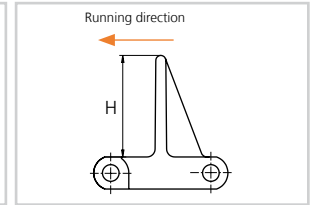
Dimensional Sketches

uni OPB Product Support
No Cling

uni OPB Product Support
No Cling with Ribs

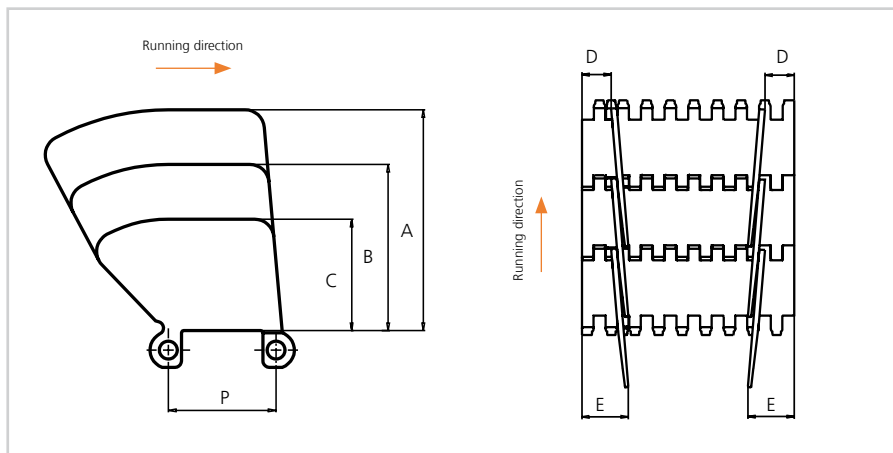
Standard Materials, Colors and Dimensions

Style	H		Width			Standard materials & colors
	mm	in.				
uni OPB 4V PS No Cling	50.8	2.00	K600	151.0	5.94	PPHW B
	76.2	3.00				
	101.6	4.00				
uni OPB 4V PS No Cling with Ribs	50.8	2.00	K600	151.0	5.94	PPHW B
	76.2	3.00				
	101.6	4.00				
uni OPB 4V 23F PS No Cling	101.6	4.00	K600	151.0	5.94	PPHW B
uni OPB 4V 23F PS No Cling with Ribs	76.2	3.00	K600	151.0	5.94	PPHW B
	101.6	4.00				

uni OPB Side Guard

Dimensions

	mm	in.
A	102.6	4.04
B	77.2	3.04
C	51.8	2.04
D*	21.0	0.83
E*	34.0	1.34
P	50.0	1.97

* Min. indent
Increment: 8.4 mm (0.33 in.)

Standard Materials and Colors

PA6 **B** PPHW **B**

Accessories | Finger Plate

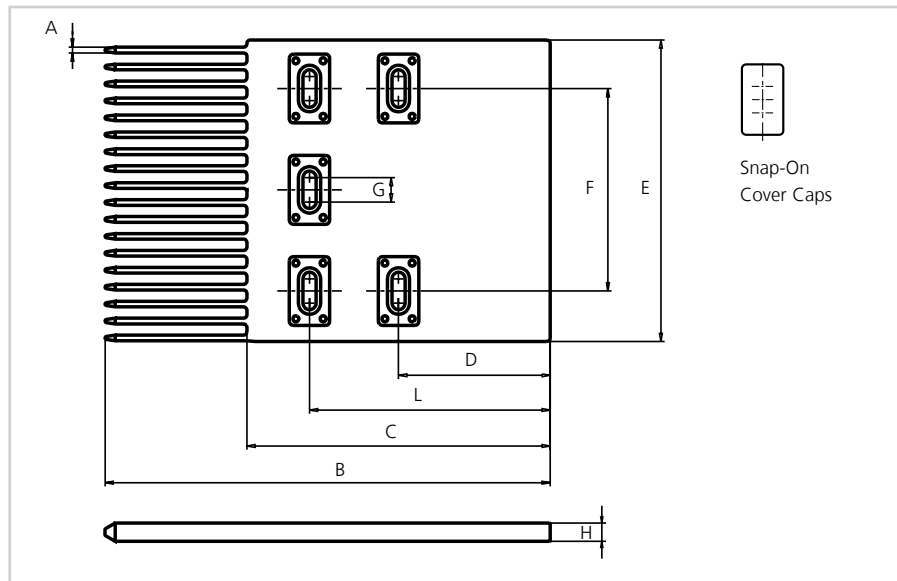

uni OPB Finger Plate Type 1A

Dimensions

	mm	in.
A	2.8	0.11
B	220.0	8.66
C	150.0	5.91
D	75.0	2.95
E	149.0	5.87
F	100.0	3.94
G	12.0	0.47
H	9.0	0.35
L	119.0	4.69
M	123.0	4.84
N	22.0	0.87
O	53.0	2.09

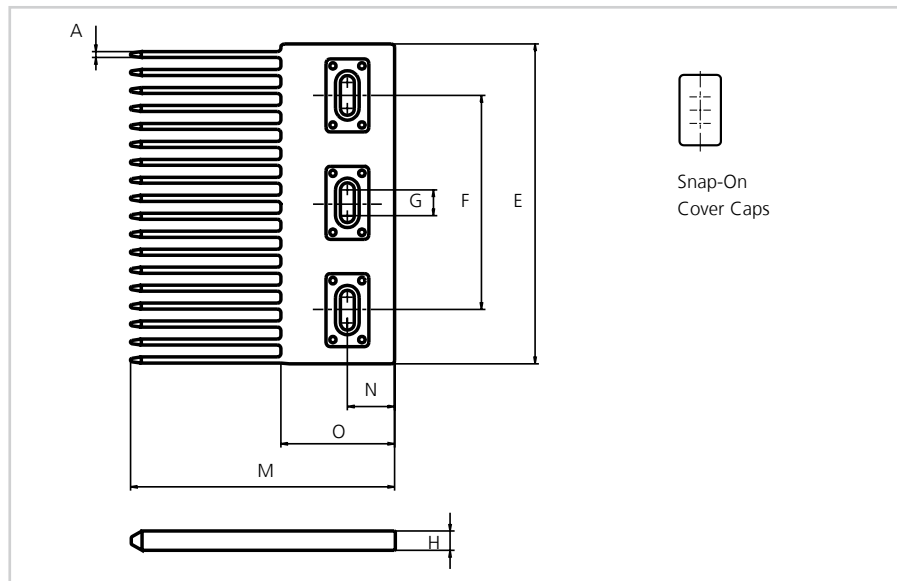

uni OPB Finger Plate Type 2

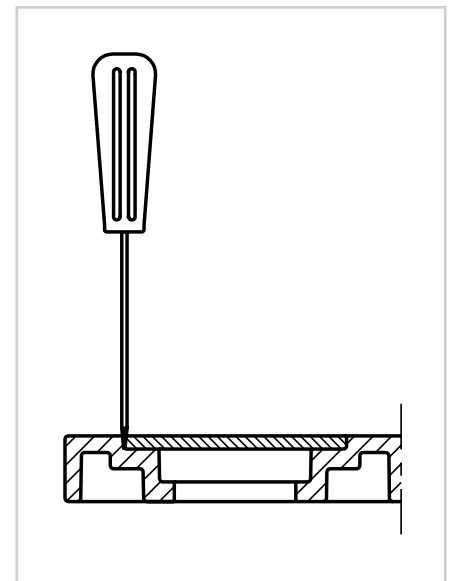

All uni-chains belt systems are available in a raised rib version and can be supplied with matching finger plates, also called combs.

The finger plates are supplied with cover caps which can be attached when the finger plate has been installed. The cover caps can be removed by using

a screwdriver that can be inserted between the cover and finger plate.

Standard Material and Color

POM-DI G

Pitch 50.8 mm (2.00 in.)



uni BLB – the perfect belt for cooking, steaming and blanching

The uni BLB design combines plastic with stainless steel. A unique belt surface ensures that the conveyed products are only in contact with plastic without abandoning the advantages of stainless steel. The plastic and stainless steel combination thus prevents belt elongation and strength reduction at water boiling temperatures. This makes uni BLB ideal for handling all sorts of sensitive products like vegetables, fruits and pasta. With the special surface openings, even rice can be handled by uni BLB. This makes uni BLB ideal for handling all sorts of sensitive products like vegetables, fruits and pasta. With the unique surface

openings even rice can be handled on uni BLB.

The uni BLB belt increases performance in the following industries/applications:

- Blanching of vegetables & rice
- Cooking or precooking of fresh pasta
- Steaming of rice & pasta
- Cooking and cooling of fish & shellfish

Product features and operational benefits:

- Improved product quality as the belt surface ensures minimum product damage and easy release from the belt

- No marking on the products from the belt surface
- No product contamination or damage due to contact with stainless steel
- Long life and low maintenance costs
- Simplified and reliable equipment design as belt elongation due to temperature is reduced by 90% compared to all plastic belts
- Higher product yield due to hygienic design and less cleaning time
- Increased equipment utilisation as various products can be handled on the same belt. Making the equipment less depending on short harvesting seasons

Standard Selection

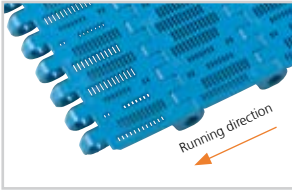

uni BLB
Surface opening 18%, Top



uni BLB
with reinforcement links, bottom

Dimensional Sketch

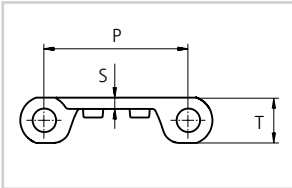

uni BLB

Dimensions

	mm	in.
P	50.8	2.00
S	4.0	0.16
T	16.0	0.63

- Straight running
- 50.8 mm (2.00 in.)
- $\varnothing 8.0$ mm (0.31 in.)
- Patent pending
- See page 11
- 65 mm (2.6 in.)
Side Guards: 200 mm (7.9 in.)
- See page 93
- See page 171

Alternatives



Accessories



Standard Materials and Colors

Type	Standard materials and colors	Standard pin materials and colors	Standard lock materials and colors
uni BLB	PPHW LB	SS304	PPHW LB
uni BLB with side guards	PPHW LB	SS304	PPHW LB

Standard Bricklaid Belt Widths

mm	in.	mm	in.	mm	in.	mm	in.
152	6.0	507	20.0	1167	45.9	1623	63.9
254	10.0	558	22.0	1268	49.9	1775	69.9
305	12.0	609	24.0	1369	53.9	1927	75.9
355	14.0	761	30.0	1454	57.2	1979	77.9
406	16.0	964	38.0	1504	59.2	2029	79.9
457	18.0	1065	41.9	1572	61.9	2181	85.9

On above belt width values, the belt width tolerance on standard materials is +0/-0.4% at 23°C/73°F.

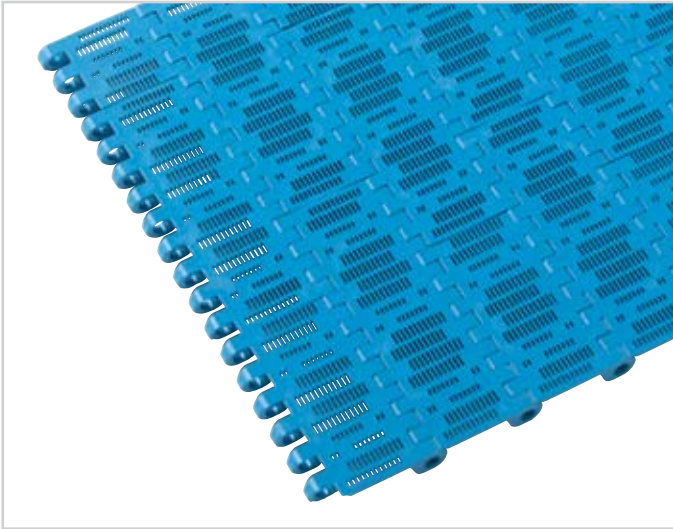
uni BLB Single Link®

uni BLB Single Link® is available in the following standard widths:

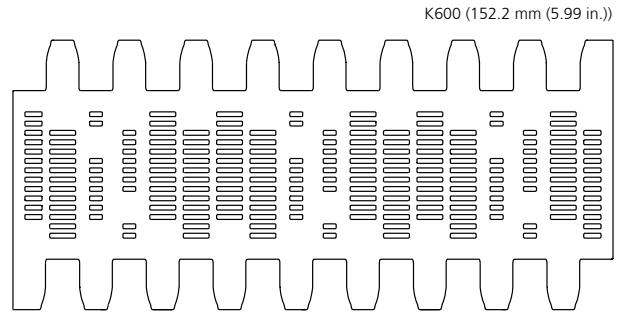
Belt Weights

Belt material	PPHW		PPHW	
	SS		PP	
Pin material	kg/m ²	lb/ft ²	kg/m ²	lb/ft ²
uni BLB with reinforcement	12.7	2.60	-	-
uni BLB without reinforcement	11.7	2.40	4.8	0.98

Max. Permissible Load

Belt material	PPHW		PPHW	
	SS		PP	
Pin material	N/row	lbf/row	N/m	lbf/ft
uni BLB with reinforcement*	2500	562	-	-
uni BLB without reinforcement	-	-	3300	226

* Load capacity per row of reinforcement links in the belt. Maximum 19 rows per metre belt width.
 Example: If seven rows are installed the max. permissible load of the belt is 7 x 2500 N(562 lbf) = 17500 N(3934 lbf).

Standard Sprockets

No. of teeth	Pitch diameter		Overall diameter		Hub diameter		Bore		Reference no. plastic
	mm	in.	mm	in.	mm	in.	mm	in.	
6	101.6	4.00	99.5	3.92	65.0	2.56	∅18.0/40.0*	∅0.71/1.57*	183PA6MPBH06111N00
							sq 38.1	sq 1.50	183PA6MPBH06111N00I150S
							sq 40.0	sq 1.57	183PA6MPBH06111LG00M040S
8	132.8	5.23	132.9	5.23	65.0	2.56	∅18.0/40.0*	∅0.71/1.57*	183PA6MPBH08111LG00
							sq 38.1	sq 1.50	183PA6MPBH08111LG00I150S
							sq 40.0	sq 1.57	183PA6MPBH08111N00M040S
					100.0	3.94	sq 50.8	sq 2.00	183PA6MPBH08111N00I200S
10	164.4	6.47	166.3	6.55	65.0	2.56	∅18.0/40.0*	∅0.71/1.57*	183PA6MPBH10111N00
							sq 38.1	sq 1.50	183PA6MPBH10111N00I150S
							sq 40.0	sq 1.57	183PA6MPBH10111LG00M040S
					120.0	4.72	∅40.0/70.0*	∅1.57/2.76*	183PA6MPBH10111LG01
							sq 50.8	sq 2.00	183PA6MPBH10111N00I200S
							sq 63.5	sq 2.50	183PA6MPBH10111N00I250S
sq 60.0	sq 2.36	183PA6MPBH10111LG00M060S							
12	196.3	7.73	198.6	7.82	65.0	2.56	∅18.0/40.0*	∅0.71/1.57*	183PA6MPBH12111LG02
							sq 38.1	sq 1.50	183PA6MPBH12111N00I150S
							sq 40.0	sq 1.57	183PA6MPBH12111N00M040S
					120.0	4.72	∅40.0/70.0*	1.57/2.76*	183PA6MPBH12111N01
							sq 50.8	sq 2.00	183PA6MPBH12111N00I200S
sq 60.0	sq 2.36	183PA6MPBH12111N00M060S							
16	260.4	10.25	263.8	10.04	65.0	2.56	∅18.0/40.0*	∅0.71/1.57*	183PA6MPBH16111N00
					150.0	5.91	∅40.0/70.0*	1.57/2.76*	183PA6MPBH16111N01

* Minimum/maximum round bore.

Placement of Wearstrips and Sprockets

No. of teeth	Minimum B-dimension		Wearstrip distance A	
	mm	in.	mm	in.
6	60.9	2.40	36.2	1.43
8	76.8	3.02	53.6	2.11
10	92.8	3.65	70.5	2.78
12	108.8	4.28	87.2	3.43
16	141.1	5.56	120.2	4.73

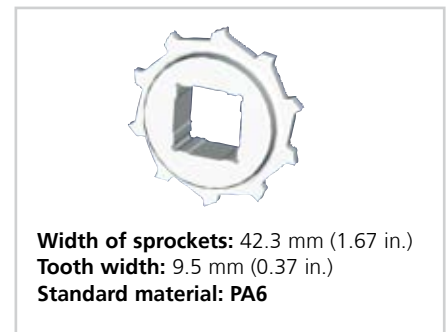
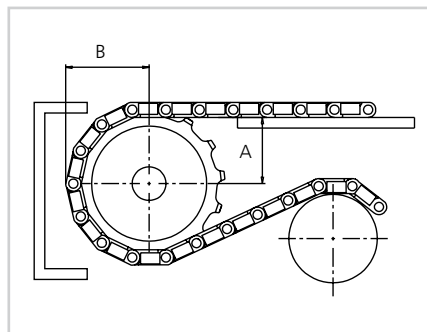

Other sprocket sizes are available upon request. Two-part sprockets are available upon request. Please note, if travel is in both directions, an extra set of sprockets is required. Alternatively, use bi-directional options.

Max. Load per Sprocket

Belt material	POM	
	N	lbf
uni BLB with snub roller	2000	450
uni BLB without snub roller	1250	281

Accessories | Side Guard

Dimensional Sketches

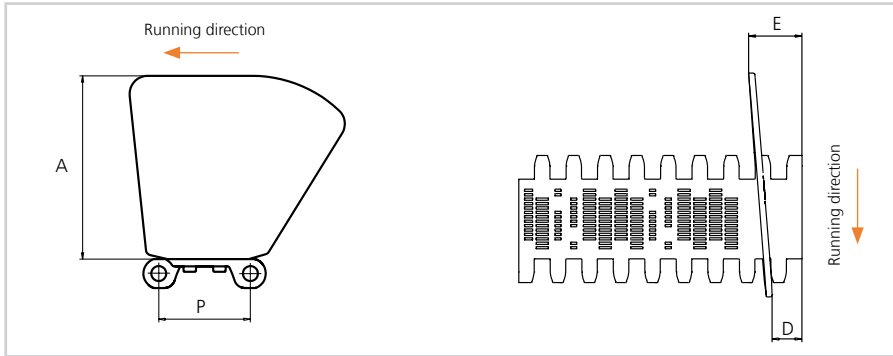

uni BLB Side Guard left

Dimensions

	mm	in.
A	101.6	4.00
D	16.0	0.63
E	28.5	1.12
P	50.8	2.00

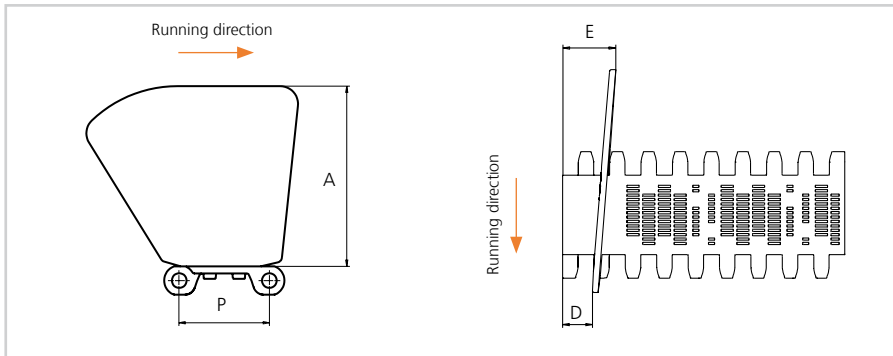

uni BLB Side Guard right

Standard Material and Color

PPHW **LB**

Pitch 50.8 mm (2.00 in.)



uni RTB - State of The Art in Roller Top Modular Belts

The new uni RTB belt is the most flexible and reliable handling solution for your products to be conveyed.

Numerous variation options in roller positioning makes uni RTB the smartest straight running modular belt.

The Pinless Snap Link® enables easy assembling and provides product reliability.

uni RTB – will be the Number One Belt in the following Industries/ Applications:

Material handling applications
Tyre and rubber industries:

- Collector belt of finished tires from vulcanizing/curing presses
- Final finish tire handling
- Sorting application
- Merging application
- 90-180 degree turning
- Tyre accumulation
- Semiproducts handling
- Rubber tape slitting equipment

Product features and operational benefits:

- High efficiency with elimination of jams, line stoppages and product damage
- Simultaneous handling of many product sizes without controls or manual adjustments
- Facilitated roller maintenance
- Pinless Snap Link® concept for easy assembly and product reliability
- Roller height above belt surface three and six mm (M1 and M2)
- Flexible roller positioning
Rollers in six different positions: 0°, 30°, 60°, 90°, 120° and 150°
- M2 rollers for active conveying
- No rollers blocking even with sticky rubber

Standard Selection



uni RTB M1



uni RTB M2

Dimension for rollers

uni RTB M1: 17.9 mm (0.70 in.)
uni RTB M2: 23.9 mm (0.94 in.)

- Straight running
- 50.8 mm (2.00 in.)
- See page 11
- 65.0 mm (2.56 in.)
- See page 98
- See page 171

Dimensional Sketches

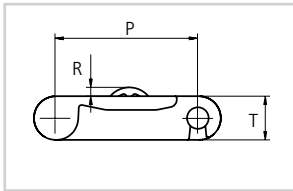

uni RTB M1

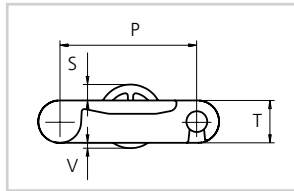

uni RTB M2

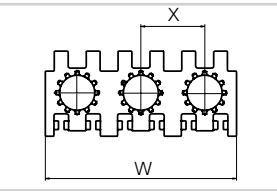

uni RTB M1 | uni RTB M2

Roller position

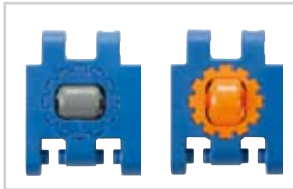

uni RTB M1 | uni RTB M2
000°

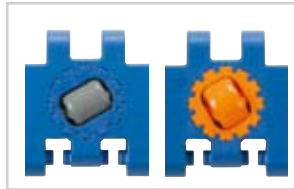

uni RTB M1 | uni RTB M2
030°

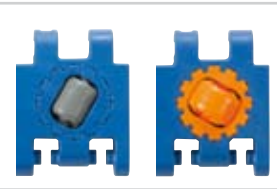

uni RTB M1 | uni RTB M2
060°

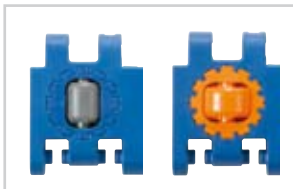

uni RTB M1 | uni RTB M2
090°

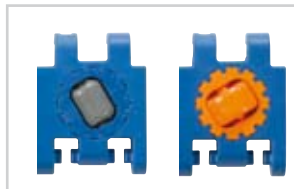

uni RTB M1 | uni RTB M2
120°

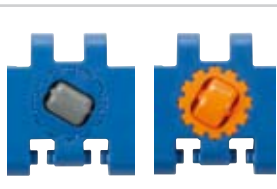

uni RTB M1 | uni RTB M2
150°

Dimensions

	mm	in.
P	50.8	2.00
T	16.0	0.63
R	3.0	0.12
S	6.0	0.24
V	2.0	0.08
W	152.8	6.00
X	50.8	2.00

uni RTB M1

The rollers are only extending on one side of the belt - the top. Accumulation roller provide less friction between the belt and the conveyed product and ensure the best possible sideways loading of the belt.

uni RTB M2

The rollers are only extending on two sides of the belt - the top and the bot-

tom. When the belt rollers are rotating, the conveyed products will move faster than the belt. When the belt rollers do not rotate, the conveyed product will travel at belt speed.

Mounting positions

0° = Rollers rotate in travel direction.

30° = Roller pins angled counter clockwise 30° (move products to the left).

60° = Roller pins angled counter clockwise 60° (move products to the left).

90° = Roller pins rotate perpendicularly to the travel direction.

120° = Roller pins angled counter clockwise 120° (move products to the right).

150° = Roller pins angled counter clockwise 150° (move products to the right).

Standard Materials and Colors

Type	Standard materials and colors	Standard roller materials and colors	Standard cover plate materials and colors	Standard pin for rollers
uni RTB M1	POM-S B	POM-NL G	POM-NL B	SS304
uni RTB M2	POM-S B	POM-NL O	POM-NL O	SS304

Standard Bricklaid Belt Widths

mm	in	mm	in	mm	in	mm	in
153	6.0	509	20.0	865	34.1	1222	48.1
204	8.0	560	22.0	916	36.1	1273	50.1
255	10.0	611	24.0	967	38.1	1323	52.1
305	12.0	662	26.1	1018	40.1	1374	54.1
356	14.0	713	28.1	1069	42.1	1425	56.1
407	16.0	764	30.1	1120	44.1	1476	58.1
458	18.0	814	32.1	1171	46.1	1527	60.1

On above belt width values, the belt width tolerance on standard materials is +0/-0.4% at 23°C/73°F

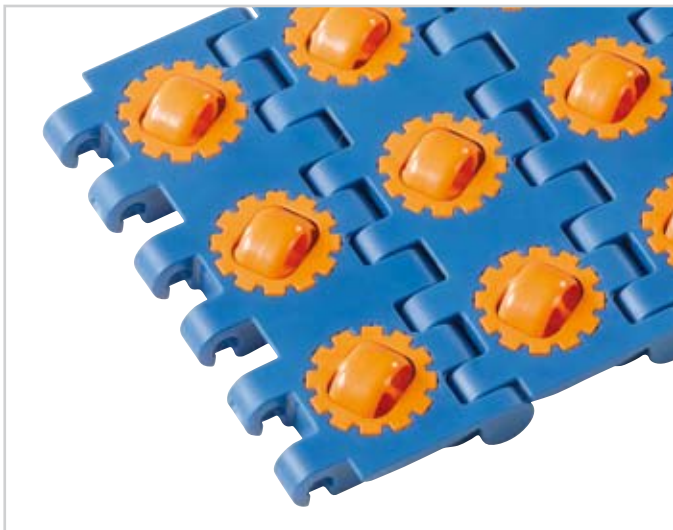
uni RTB Single Link®

uni RTB Single Link® is available in the following standard width:

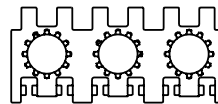

K600 (152.8 mm (6.00 in.))

Belt Weights

Belt material	POM	
	kg/m ²	lb/ft ²
uni RTB M1 uni RTB M2	20.1	4.12

Permissible Tensile Strength

Belt material	POM	
	N/m	lbf/ft
uni RTB M1 uni RTB M2	27500	1884

Max. Load per Roller

Belt material	Max. permissible static load		Max. permissible dynamic load	
	N	lbf	N	lbf
uni RTB M1	3000	674	100	23
uni RTB M2	2000	449	100	23

Standard Sprockets

No. of teeth	Pitch diameter		Overall diameter		Hub diameter		Bore		Reference no. plastic
	mm	in.	mm	in.	mm	in.	mm	in.	
6	101.6	4.00	99.5	3.92	65.0	2.56	∅18.0/40.0*	∅0.71/1.57*	183PA6MPBH06111N00
							sq 38.1	sq 1.50	183PA6MPBH06111N00I150S
							sq 40.0	sq 1.57	183PA6MPBH06111LG00M040S
8	132.8	5.23	132.9	5.23	65.0	2.56	∅18.0/40.0*	∅0.71/1.57*	183PA6MPBH08111LG00
							sq 38.1	sq 1.50	183PA6MPBH08111LG00I150S
							sq 40.0	sq 1.57	183PA6MPBH08111N00M040S
					100.0	3.94	sq 50.8	sq 2.00	183PA6MPBH08111N00I200S
10	164.4	6.47	166.3	6.55	65.0	2.56	∅18.0/40.0*	∅0.71/1.57*	183PA6MPBH10111N00
							sq 38.1	sq 1.50	183PA6MPBH10111N00I150S
							sq 40.0	sq 1.57	183PA6MPBH10111LG00M040S
					120.0	4.72	∅40.0/70.0*	∅1.57/2.76*	183PA6MPBH10111LG01
							sq 50.8	sq 2.00	183PA6MPBH10111N00I200S
							sq 63.5	sq 2.50	183PA6MPBH10111N00I250S
sq 60.0	sq 2.36	183PA6MPBH10111LG00M060S							
12	196.3	7.73	198.6	7.82	65.0	2.56	∅18.0/40.0*	∅0.71/1.57*	183PA6MPBH12111LG02
							sq 38.1	sq 1.50	183PA6MPBH12111N00I150S
							sq 40.0	sq 1.57	183PA6MPBH12111N00M040S
					120.0	4.72	∅40.0/70.0*	1.57/2.76*	183PA6MPBH12111N01
							sq 50.8	sq 2.00	183PA6MPBH12111N00I200S
sq 60.0	sq 2.36	183PA6MPBH12111N00M060S							
16	260.4	10.25	263.8	10.04	65.0	2.56	∅18.0/40.0*	∅0.71/1.57*	183PA6MPBH16111N00
					150.0	5.91	∅40.0/70.0*	1.57/2.76*	183PA6MPBH16111N01

* Minimum/maximum round bore.

Placement of Wearstrips and Sprockets

No. of teeth	Minimum B-dimension		Wearstrip distance A	
	mm	in.	mm	in.
6	59.5	2.34	36.2	1.43
8	75.1	2.96	53.6	2.11
10	91.0	3.58	70.5	2.78
12	107.0	4.21	87.2	3.43
16	139.2	5.48	120.2	4.73

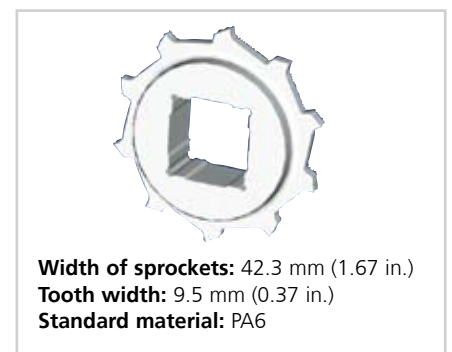
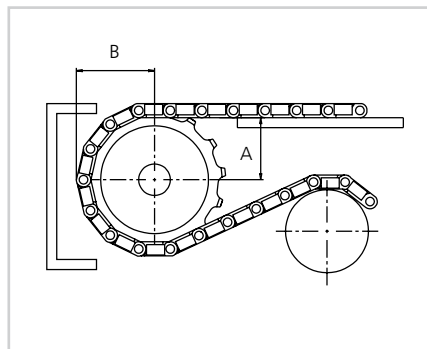

Other sprocket sizes are available upon request. Two-part sprockets are available upon request.

Max. Load per Sprocket

Belt material	POM	
	N	lbf
uni RTB M1 uni RTB M1	2000	450

Pitch 50.8 mm (2.00 in.)



uni CPB – a strong and wear resistant belt

The uni CPB 2 in. pitch, straight running belt is made for heavy duty conveyors. It replaces steel slat top chains and other technologies being used for high wear or heavy duty applications.

The uni CPB (Closed and Rough Top) belts have increased performance in the following industries/applications:

- Automotive applications including manrider belts, car conveyors and leak tests
- Carwash applications including carwash interior detailing areas
- Material handling applications including pallet handling and other heavy duty product applications
- Meat applications (beef & pork) including hook lines and hide takeaway conveyors
- Bakery applications including stacked pan handling and packaging lines
- People moving applications including ski lifts and amusement parks

Product features and operational benefits:

- No lubrication required
- Easy maintenance and less downtime with unique (lockpin system)
- Reduced noise level
- Extremely wear and impact resistant
- Unique sprocket engagement allowing long conveyors with reduced pulsation
- Rough top surface reducing slippage and allowing safe movements

Standard Selection

uni CPB C

uni CPB 20% Rough

uni CPB C Rough

uni CPB Rubber Top
Type RB1

uni CPB Rubber Top
Type RB2

The color of standard rubber material is black. However, as it is hardly possible to see black rubber on black links, the links have been illustrated with rubber in color natural.

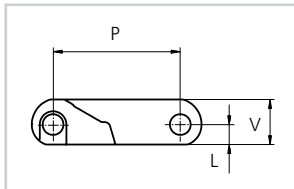
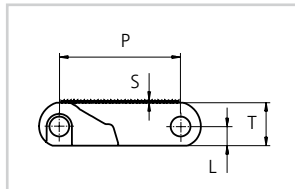
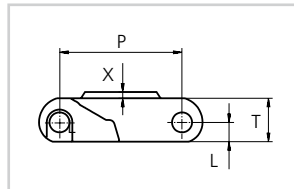
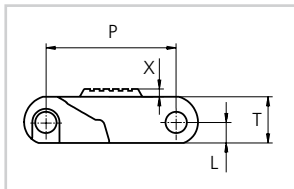
Dimensional Sketches

uni CPB C

uni CPB 20% Rough
uni CPB C Rough

uni CPB Rubber Top
Type RB1

uni CPB Rubber Top
Type RB2

- Straight running
- 50.8 mm (2.00 in.)
- Lockpin
- $\varnothing 8$ mm (0.31 in.)
- Materials** See page 11
- 85 mm (3.3 in.)
- See page 102 and 103
- See page 171
- 09 K** See page 16

Accessories

- See page 103

Dimensions

	mm	in.
L	8.0	0.31
P	50.8	2.00
S	1.0	0.04
T	18.0	0.71
V	19.0	0.75
X	3.0	0.12

Standard Materials and Colors

Type	Standard materials and colors	Standard pin materials and colors
uni CPB C	POM-NLAS K	PA6.6 N
	POM-NL K	PA6.6 N
	PP G	PA6.6 N
uni CPB 20% Rough	POM-NLAS K	PA6.6 N
	POM-NL K	PA6.6 N
uni CPB C Rough	POM-NL K	PA6.6 N
	POM-NLAS K	PA6.6 N
uni CPB Rubber Top RB1 and RB2	POM-NL K + 09 K	PA6.6 N

Standard Bricklaid Belt Widths (See below for Single Link® width)

mm	in.	mm	in.	mm	in.	mm	in.
150	5.9	651	25.6	1151	45.3	1652	65.0
200	7.9	701	27.6	1201	47.3	1702	67.0
250	9.8	751	29.6	1252	49.3	1752	69.0
300	11.8	801	31.5	1302	51.3	1802	70.9
350	13.8	851	33.5	1352	53.2	1852	72.9
401	15.8	901	35.5	1402	55.2	1902	74.9
451	17.8	951	37.4	1452	57.2	1952	76.9
501	19.7	1001	39.4	1502	59.1	2002	78.8
551	21.7	1051	41.4	1552	61.1	2052	80.8
601	23.7	1101	43.3	1602	63.1	2102	82.8

On above belt width values, the belt width tolerance on standard materials is +0/-0.4% at 23°C/73°F.

uni CPB Single Link®



uni CPB Single Link® is available in the following standard width:

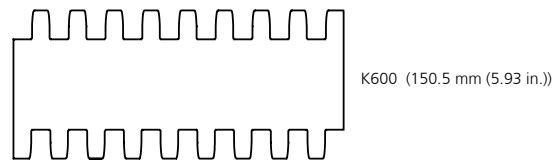

Belt Weights

Belt material	POM		PP	
	PA6.6		PA6.6	
Pin material	kg/m ²	lb/ft ²	kg/m ²	lb/ft ²
uni CPB C 20% Rough C Rough Rubber Top	16.6	3.40	11.1	2.27

Permissible Tensile Strength

Belt material	POM		PP	
	PA6.6		PA6.6	
Pin material	N/m	lbf/ft	N/m	lbf/ft
uni CPB C 20% Rough C Rough Rubber Top	52000	3563	35000	2398

Standard Sprockets

No. of teeth	Pitch diameter		Overall diameter		Hub diameter		Bore		Reference no. plastic
	mm	in.	mm	in.	mm	in.	mm	in.	
6	101.6	4.00	99.5	3.92	65.0	2.56	∅18.0/40.0*	∅0.71/1.57*	183PA6MPBH06111N00
							sq 38.1	sq 1.50	183PA6MPBH06111N00I150S
							sq 40.0	sq 1.57	183PA6MPBH06111LG00M040S
8	132.8	5.23	132.9	5.23	65.0	2.56	∅18.0/40.0*	∅0.71/1.57*	183PA6MPBH08111LG00
							sq 38.1	sq 1.50	183PA6MPBH08111LG00I150S
							sq 40.0	sq 1.57	183PA6MPBH08111N00M040S
					100.0	3.94	sq 50.8	sq 2.00	183PA6MPBH08111N00I200S
10	164.4	6.47	166.3	6.55	65.0	2.56	∅18.0/40.0*	∅0.71/1.57*	183PA6MPBH10111N00
							sq 38.1	sq 1.50	183PA6MPBH10111N00I150S
							sq 40.0	sq 1.57	183PA6MPBH10111LG00M040S
					120.0	4.72	∅40.0/70.0*	∅1.57/2.76*	183PA6MPBH10111LG01
							sq 50.8	sq 2.00	183PA6MPBH10111N00I200S
							sq 63.5	sq 2.50	183PA6MPBH10111N00I250S
sq 60.0	sq 2.36	183PA6MPBH10111LG00M060S							
12	196.3	7.73	198.6	7.82	65.0	2.56	∅18.0/40.0*	∅0.71/1.57*	183PA6MPBH12111LG02
							sq 38.1	sq 1.50	183PA6MPBH12111N00I150S
							sq 40.0	sq 1.57	183PA6MPBH12111N00M040S
					120.0	4.72	∅40.0/70.0*	1.57/2.76*	183PA6MPBH12111N01
							sq 50.8	sq 2.00	183PA6MPBH12111N00I200S
sq 60.0	sq 2.36	183PA6MPBH12111N00M060S							
16	260.4	10.25	263.8	10.04	65.0	2.56	∅18.0/40.0*	∅0.71/1.57*	183PA6MPBH16111N00
					150.0	5.91	∅40.0/70.0*	1.57/2.76*	183PA6MPBH16111N01

* Minimum/maximum round bore.

Placement of Wearstrips and Sprockets

No. of teeth	Minimum B-dimension		Wearstrip distance A	
	mm	in.	mm	in.
6	60.9	2.40	36.2	1.43
8	76.8	3.02	53.6	2.11
10	92.8	3.65	70.5	2.78
12	108.8	4.28	87.2	3.43
16	141.1	5.56	120.2	4.73

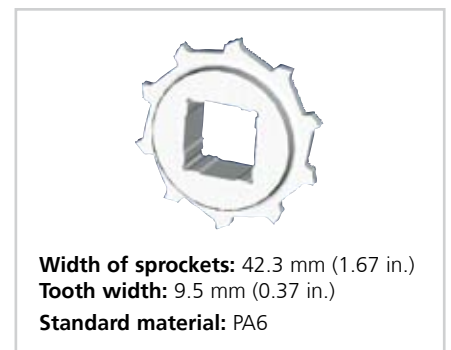
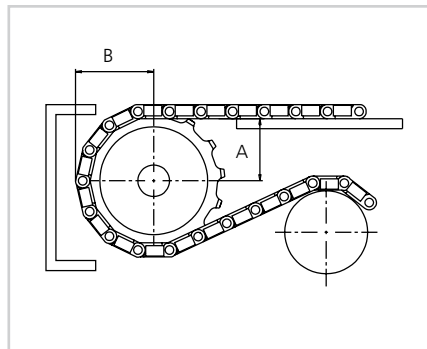

Other sprocket sizes are available upon request. Two-part sprockets are available upon request.

Please note, if travel is in both directions, an extra set of sprockets is required. Alternatively use bi-directional options. (See next page.)

Max. Load per Sprocket

Belt material	POM	
	N	lbf
uni CPB	2500	560

Standard Bi-directional Sprockets

No. of teeth	Pitch diameter		Overall diameter		Hub diameter		Bore		Reference no. plastic
	mm	in.	mm	in.	mm	in.	mm	in.	
10	164.4	6.47	166.3	6.55	65.0 ¹⁾	2.56	∅18.0/40.0*	∅0.71/1.57*	183PA6MPBH10221N00
							sq 38.1	sq 1.50	183PA6MPBH10221N00I150S
							sq 40.0	sq 1.57	183PA6MPBH10221LG00M040S
					120.0 ¹⁾	4.72	∅40.0/70*	∅1.57/2.76*	183PA6MPBH10221N01
							sq 60.0	sq 2.36	183PA6MPBH10221N00M060S
							sq 63.5	sq 2.50	183PA6MPBH10221N00I250S
12	196.3	7.73	198.6	7.82	120.0 ¹⁾	4.72	sq 60.0	sq 2.36	183PA6MPBH12221N00M060S
					113.0 ²⁾	4.45	sq 60.0	sq 2.36	183PA6MPBH12221LG01M060S
					156.0 ²⁾	6.14	sq 90.0	sq 3.54	183PA6MPBH12221LG01M090S
16	260.4	10.25	263.8	10.04	160.0 ³⁾	6.30	sq 60.0	sq 2.36	183PA6MPBH16221N00M060S*
							sq 90.0	sq 3.54	183PA6MPBH16221N00M090S*
					114.0 ²⁾	4.49	sq 60.0	sq 2.36	183PA6MPBH16221LG01M060S**
					156.0 ²⁾	6.14	sq 90.0	sq 3.54	183PA6MPBH16221LG01M090S**

* Minimum/maximum round bore.

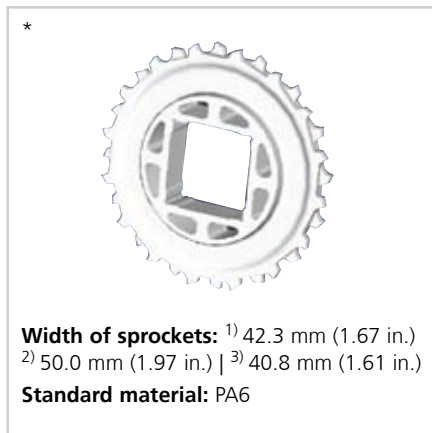

Other sprocket sizes are available upon request. Two-part sprockets are available upon request.

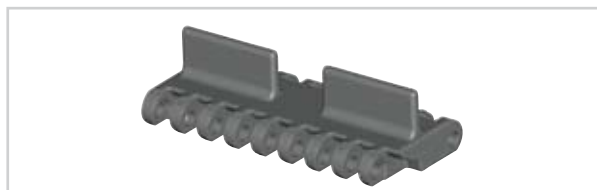
Accessories | Product Support

uni CPB Product Support
Flat (no Ribs)

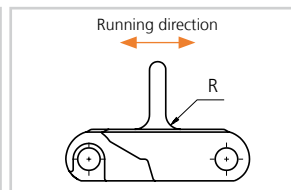
Dimensional Sketch

uni CPB Product Support
Flat (no Ribs)

Dimensions

	mm	in.
R	5.5	0.22

Cap between Product Supports is 30.0 mm (1.18 in.)

Standard Materials, Colors and Dimensions

Height		Width			Standard materials & colors
mm	in.	Type	mm	in.	POM-NLAS
25.4	1.00	K600	150.5	5.93	K

Pitch 50.8 mm (2.00 in.)



uni MPB – the most cleanable plastic modular belt in the world

The uni MPB belt is the most cleanable, 2 in. pitch, straight running plastic modular belt in the world and the belt holds the valid NSF/USDA approvals. The belt is used in various food applications and offers various styles from closed and open surfaces to roller or rubber top.

The uni MPB belt is the preferred belt in the following industries/applications:

- Meat applications (beef & pork) including deboning lines, fat/trim lines, cutting lines, offal lines, evisceration lines,
- Poultry applications including cage dumper lines, deboning lines, fat/trim lines, offal lines, grading lines, packaging lines and elevator/incline conveyors
- Fruit & vegetable applications including elevators, steam peeler lines, inspection tables, blanchers and packaging lines
- Seafood applications including bulk feeder, elevators, inspection tables, grading lines, glazing lines, cooling and freezing lines
- Snack food applications including fryer discharge and incline applications

Product features and operational benefits:

- Easy to clean Single Link® belt (no brick lay) reducing downtime for cleaning with up to 70%
- Single Link® belt reducing bacteria growth and eliminating knives sticking in belt seams
- Unique lockpin locking system
- Unique sprocket engagement
- Strong and thick product supports allowing load without breakage
- Stick and non stick surfaces allowing optimized product throughput

Standard Selection

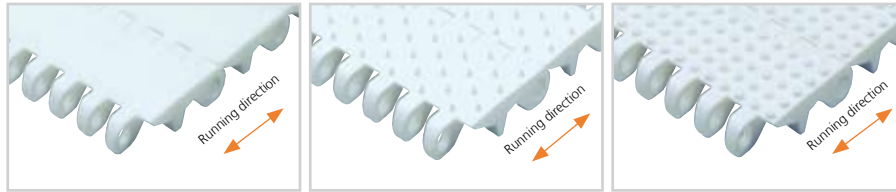

uni MPB C

uni MPB G*

uni MPB N*

* Indent: uni MPB GE and uni MPB NE are 35.0 mm (1.38 in.).



uni MPB 18%

uni MPB 20%

uni MPB 22%



uni MPB PRR

uni MPB RO

uni MPB Rubber Top
Type RB4

Dimensional Sketches

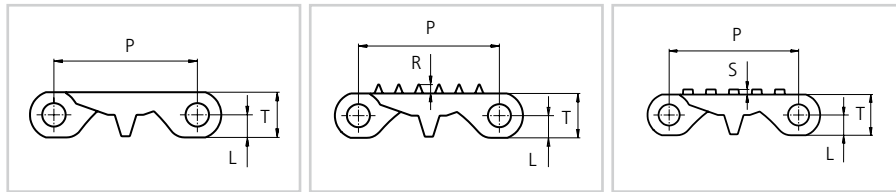

uni MPB | uni MPB 18%
uni MPB 20% | uni MPB 22%

uni MPB G | uni MPB GE

uni MPB N | uni MPB NE

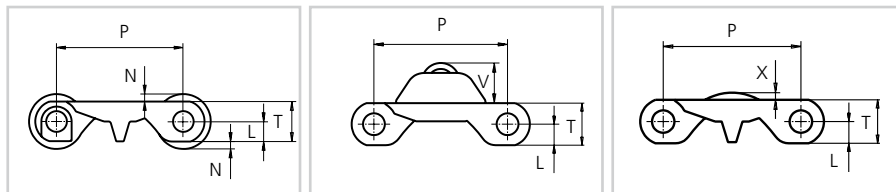

uni MPB RO

uni MPB PRR

uni MPB Rubber Top
Type RB4



Straight running



50.8 mm (2.00 in.)



ø8 mm (0.31 in.)



Patented



See page 11



65 mm (2.6 in.)
Side Guards: 200 mm (7.9 in.)



See pages 109 and 110



See page 171



01 **N** See page 16

Alternative



PP **W** PE **W** PA6.6 **N**
SS304

Accessories



See page 112



See page 111



See page 112

Dimensions

	mm	in.
L	8.0	0.31
N	3.0	0.12
P	50.8	2.00
R	3.2	0.13
S	2.0	0.08
T	16.0	0.63
V	15.3	0.60
X	3.5	0.14

Standard Materials and Colors

Type	Standard materials and colors	Standard pin materials and colors
uni MPB C	POM-DI W	PP W
	POM-DI B	PP W
	PP W	PP W
	PP B	PP W
	PE-I N	PE W
	PE-I B	PE W
uni MPB G uni MPB GE	POM-DI W	PP W
uni MPB N uni MPB NE	PE-I N	PE W
uni MPB 18%	POM-DI W	PP W
	PP W	PP W
	PE-I N	PE W
uni MPB 20%	PE-I N	PE W
	PP W	PP W
uni MPB 22%	PE-I N	PE W
	PE-I B	PE W
	PP W	PP W
uni MPB Rubber Top RB4	POM-DI N + 01 N	PA6.6 N

Standard Materials and Colors for uni MPB PRR

Type	Baselink Standard materials and colors	Standard pin materials and colors	Roller Standard materials and colors	Roller bed Standard materials and colors	Standard Roller pins
uni MPB PRR	POM-DI W	PP W	PA6.6 W	POM-DI W	SS304
	POM-DI W	PA6.6 N	PA6.6 W	POM-DI W	SS304

Standard Materials and Colors for uni MPB RO

Type	Baselink Standard materials and colors	Standard pin materials and colors	Roller Standard materials and colors
uni MPB RO	POM-DI G	PP N	POM-DI B

Standard Bricklaid Belt Widths (See below for Single Link® widths)

mm	in.	mm	in.	mm	in.	mm	in.	mm	in.	mm	in.
151	5.9	637	25.1	1022	40.2	1407	55.4	1809	71.2	2211	87.0
184	7.2	653	25.7	1055	41.5	1457	57.4	1842	72.5	2228	87.7
268	10.6	704	27.7	1089	42.9	1474	58.0	1859	73.2	2261	89.0
302	11.9	720	28.3	1106	43.5	1507	59.3	1909	75.2	2295	90.4
335	13.2	754	29.7	1156	45.5	1541	60.7	1926	75.8	2312	91.0
402	15.8	787	31.0	1173	46.2	1558	61.3	1960	77.2	2362	93.0
418	16.5	804	31.7	1206	47.5	1608	63.3	1993	78.5	2379	93.7
452	17.8	854	33.6	1240	48.8	1625	64.0	2010	79.1	2412	95.0
486	19.1	871	34.3	1256	49.4	1658	65.3	2060	81.1	2446	96.3
503	19.8	905	35.6	1307	51.5	1692	66.6	2077	81.8	2462	96.9
553	21.8	938	36.9	1323	52.1	1709	67.3	2110	83.1	2512	98.9
569	22.4	955	37.6	1357	53.4	1759	69.3	2144	84.4	-	-
603	23.7	1005	39.6	1390	54.7	1776	69.9	2161	85.1	-	-

On above belt width values, the belt width tolerance on standard materials is +0/-0.4% at 23°C/73°F.

uni MPB Single Link®

uni MPB Single Link® is available in the following standard widths:

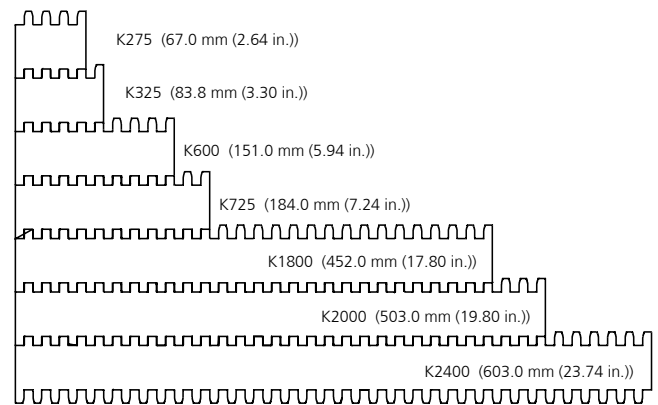
uni MPB Single Link® Belt Widths

Belt type and widths	K275 67.0 mm (2.64 in.)	K325 83.8 mm (3.30 in.)	K600 151.0 mm (5.94 in.)	K725 184.0 mm (7.24 in.)	K1800 452.0 mm (17.80 in.)	K2000 503.0 mm (19.80 in.)	K2400 603.0 mm (23.74 in.)
uni MPB C	X	X	X	X	X	X	X
uni MPB 18%	X	X	X	X			
uni MPB 20%	X	X	X	X			
uni MPB 22%			X	X			
uni MPB G uni MPB GE			X				
uni MPB N uni MPB NE			X				
uni MPB PRR			X				
uni MPB RO			X	X			
uni MPB Rubber Top			X				

Belt Weights

Belt material	POM		PP		PE	
Pin material	plastic		plastic		plastic	
	kg/m ²	lb/ft ²	kg/m ²	lb/ft ²	kg/m ²	lb/ft ²
uni MPBC G GE N NE Rubber Top	11.9	2.44	8.3	1.70	8.8	1.80
uni MPB 18%	11.1	2.27	7.5	1.54	8.0	1.64
uni MPB 20%	11.2	2.29	7.4	1.52	7.9	1.62
uni MPB 22%	10.8	2.21	7.2	1.47	7.6	1.56
uni MPB RO	11.3	2.31	-	-	-	-
uni MPB PRR*	9.3	1.91	-	-	-	-

* For total belt weights add 0.011 kg (0.024 lb) x no. of roller kits.

Permissible Tensile Strength

Belt material	POM		PP		PE	
Pin material	plastic		plastic		plastic	
	N/m	lbf/ft	N/m	lbf/ft	N/m	lbf/ft
uni MPB C 18% 20% 22% G/GE N/NE Rubber Top	27500	1884	16000	1096	13000	891
uni MPB RO	11000	754	-	-	-	-
uni MPB PRR	27500	1884	-	-	-	-

Max. Load per Roller

	Max. permissible static load		Max. permissible dynamic load (accumulation)	
	N	lbf	N	lbf
uni MPB RO	2200	495	100	23
uni MPB PRR	2000	450	300	67

Standard Sprockets

No. of teeth	Pitch diameter		Overall diameter		Hub diameter		Bore		Reference no. plastic
	mm	in.	mm	in.	mm	in.	mm	in.	
6	101.6	4.00	99.5	3.92	65.0	2.56	∅18.0/40.0*	∅0.71/1.57*	183PA6MPBH06111N00
							sq 38.1	sq 1.50	183PA6MPBH06111N00I150S
							sq 40.0	sq 1.57	183PA6MPBH06111LG00M040S
8	132.8	5.23	132.9	5.23	65.0	2.56	∅18.0/40.0*	∅0.71/1.57*	183PA6MPBH08111LG00
							sq 38.1	sq 1.50	183PA6MPBH08111LG00I150S
							sq 40.0	sq 1.57	183PA6MPBH08111N00M040S
					100.0	3.94	sq 50.8	sq 2.00	183PA6MPBH08111N00I200S
10	164.4	6.47	166.3	6.55	65.0	2.56	∅18.0/40.0*	∅0.71/1.57*	183PA6MPBH10111N00
							sq 38.1	sq 1.50	183PA6MPBH10111N00I150S
							sq 40.0	sq 1.57	183PA6MPBH10111LG00M040S
					120.0	4.72	∅40.0/70.0*	∅1.57/2.76*	183PA6MPBH10111LG01
							sq 50.8	sq 2.00	183PA6MPBH10111N00I200S
							sq 63.5	sq 2.50	183PA6MPBH10111N00I250S
sq 60.0	sq 2.36	183PA6MPBH10111LG00M060S							
12	196.3	7.73	198.6	7.82	65.0	2.56	∅18.0/40.0*	∅0.71/1.57*	183PA6MPBH12111LG02
							sq 38.1	sq 1.50	183PA6MPBH12111N00I150S
							sq 40.0	sq 1.57	183PA6MPBH12111N00M040S
					120.0	4.72	∅40.0/70.0*	1.57/2.76*	183PA6MPBH12111N01
							sq 50.8	sq 2.00	183PA6MPBH12111N00I200S
sq 60.0	sq 2.36	183PA6MPBH12111N00M060S							
16	260.4	10.25	263.8	10.04	65.0	2.56	∅18.0/40.0*	∅0.71/1.57*	183PA6MPBH16111N00
					150.0	5.91	∅40.0/70.0*	1.57/2.76*	183PA6MPBH16111N01

* Minimum/maximum round bore.

Placement of Wearstrips and Sprockets

No. of teeth	Minimum B-dimension		Wearstrip distance A	
	mm	in.	mm	in.
6	60.9	2.40	36.2	1.43
8	76.8	3.02	53.6	2.11
10	92.8	3.65	70.5	2.78
12	108.8	4.28	87.2	3.43
16	141.1	5.56	120.2	4.73

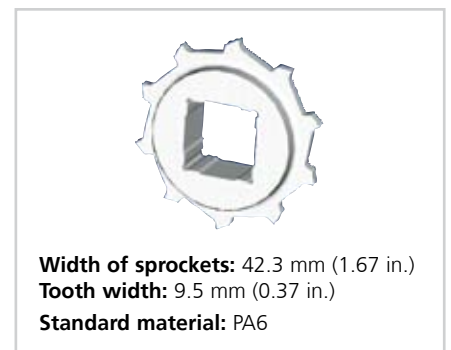
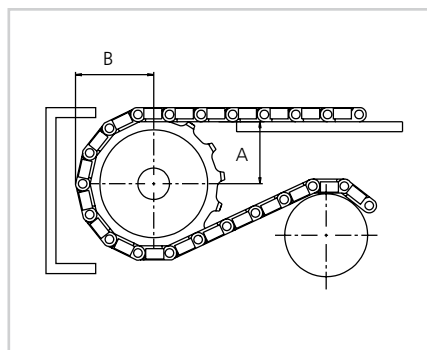

Other sprocket sizes are available upon request. Two-part sprockets are available upon request. Please note, if travel is in both directions, an extra set of sprockets is required. Alternatively use bi-directional options. (See next page.)

Max. Load per Sprocket

Belt material	POM	
	N	lbf
uni MPB with snub roller	2000	450
uni MPB without snub roller	1250	281

Standard Bi-directional Sprockets

No. of teeth	Pitch diameter		Overall diameter		Hub diameter		Bore		Reference no. plastic
	mm	in.	mm	in.	mm	in.	mm	in.	
10	164.4	6.47	166.3	6.55	65.0 ¹⁾	2.56	∅18.0/40.0*	∅0.71/1.57*	183PA6MPBH10221N00
							sq 38.1	sq 1.50	183PA6MPBH10221N00I150S
							sq 40.0	sq 1.57	183PA6MPBH10221LG00M040S
					120.0 ¹⁾	4.72	∅40.0/70*	∅1.57/2.76*	183PA6MPBH10221N01
							sq 60.0	sq 2.36	183PA6MPBH10221N00M060S
							sq 63.5	sq 2.50	183PA6MPBH10221N00I250S
12	196.3	7.73	198.6	7.82	120.0 ¹⁾	4.72	sq 60.0	sq 2.36	183PA6MPBH12221N00M060S
					113.0 ²⁾	4.45	sq 60.0	sq 2.36	183PA6MPBH12221LG01M060S
					156.0 ²⁾	6.14	sq 90.0	sq 3.54	183PA6MPBH12221LG01M090S
16	260.4	10.25	263.8	10.04	160.0 ³⁾	6.30	sq 60.0	sq 2.36	183PA6MPBH16221N00M060S*
							sq 90.0	sq 3.54	183PA6MPBH16221N00M090S*
					114.0 ²⁾	4.49	sq 60.0	sq 2.36	183PA6MPBH16221LG01M060S**
					156.0 ²⁾	6.14	sq 90.0	sq 3.54	183PA6MPBH16221LG01M090S**

* Minimum/maximum round bore.

*



Width of sprockets: ¹⁾ 42.3 mm (1.67 in.)
²⁾ 50.0 mm (1.97 in.) | ³⁾ 40.8 mm (1.61 in.)
Standard material: PA6

**



Width of sprockets: 50.0 mm (1.97 in.)
Tooth width: 17.0 mm (0.67 in.)
Standard material: PA6

Other sprocket sizes are available upon request.

Two-part sprockets are available upon request.

Accessories | Product Support

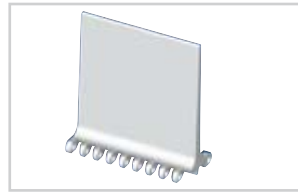

uni MPB
Product Support Flat



uni MPB
Product Support Bent

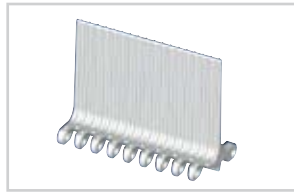

uni MPB
Product Support No Cling

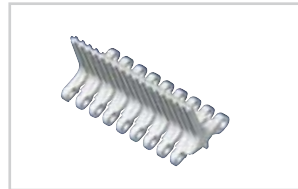

uni MPB
Product Support No Cling Drain

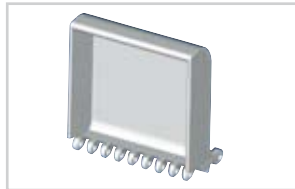

uni MPB
Product Support Cupped



uni MPB
Product Support Micro

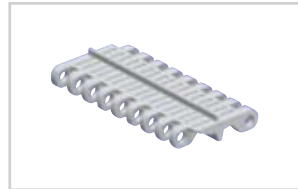

uni MPB
Product Support Micro 20%

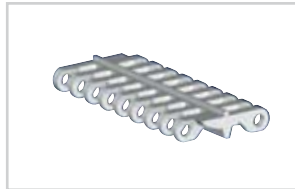

uni MPB
Product Support Micro 22%



uni MPB
Product Support molded Indent
34 mm (1.34 in.)

Note: For indent of 34 mm (1.34 in.) avoid using PP or PE lockpin, always use PA6.6 lockpin or use an alternative pin retaining system. Depending on height and spacing A the use of product supports may influence the backflex radius.

Dimensional Sketches

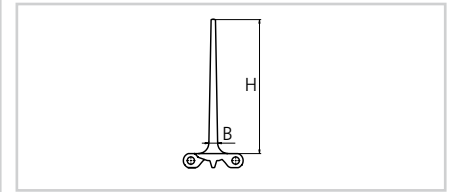

uni MPB
Product Support Flat | Bent | NC | NC Drain

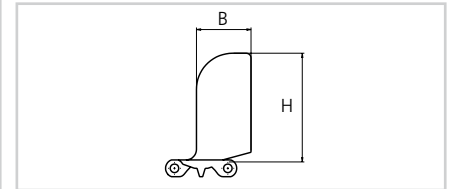

uni MPB
Product Support Cupped

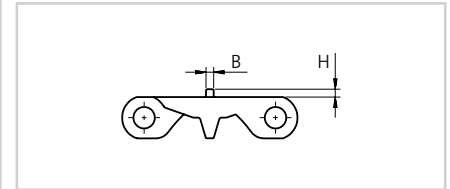

uni MPB
Product Support Micro | Micro 20% | Micro 22%

Standard Materials, Colors and Dimensions

Style	H		B		Width			Standard materials & colors		
	mm	in.	mm	in.	Type	mm	in.	POM-D	PE-I	PP-I
Product Support Flat	25.4	1.00	7.3	0.29	K600	151.0	5.94	W	B N	W B
	50.8	2.00	8.2	0.32				W B	B N	W B
	76.2	3.00	9.1	0.36				W	B N	W B
	101.6	4.00	10.0	0.39				W B		W B
	152.4	6.00	10.0	0.39				W	B N	W
Product Support Bent	76.2	3.00	9.2	0.36	K600	151.0	5.94			W
	101.6	4.00							N	W
	152.4	6.00								W
Product Support No Cling	76.2	3.00	9.6	0.38	K600	151.0	5.94		B N	W
	101.6	4.00	10.5	0.41					B N	W B
Product Support No Cling Drain	50.8	2.00	8.7	0.34	K600	151.0	5.94		B N	W B
	76.2	3.00	9.6	0.38					B N	W
	101.6	4.00	10.5	0.41					B	W B
Product Support Cupped	101.6	4.00	52.0	2.05	K600	151.0	5.94			W
Product Support Micro	5.0	0.20	3.0	0.12	K600	151.0	5.94		N	
	10.0	0.39							N	W
Product Support Micro 20%	5.0	0.20	3.0	0.12	K600	151.0	5.94		N	
Product Support Micro 22%	3.0	0.12	3.0	0.12	K600	151.0	5.94		N	W
Product Support molded indent 34 mm (1.34 in.)	101.6	4.00	10.0	0.39	K600	151.0	5.94	B		W B

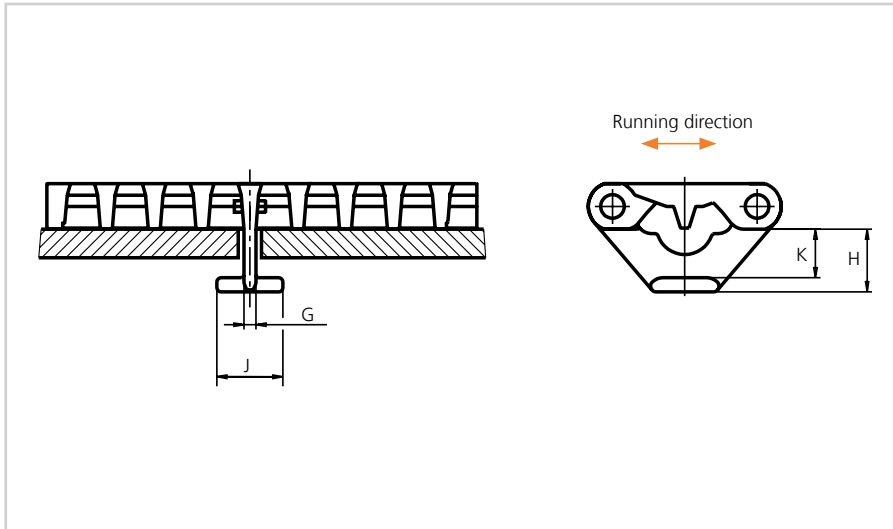
Accessories | Tab

uni MPB Tab
Dimensions

	mm	in.
G	4.2	0.17
H	22.0	0.87
J	23.2	0.91
K	17.0	0.67

Note: When using tabs, please verify sufficient clearance to the shaft.

Max. shaft diameter = Sprocket pitch diameter - 63.5 mm (2.50 in.).

When using square shafts, please verify that the diagonal does not exceed max. diameter.

Example: Sprocket z = 6: Max. shaft diameter 100.0 - 63.5 = \varnothing 36 mm (3.94 - 2.50 = \varnothing 1.4 in.).

Standard Material and Color
POM-DI W

Note: When using a belt system with tabs, the temperature should be constant. Please note that the tabs are not always placed in the middle of the belt.

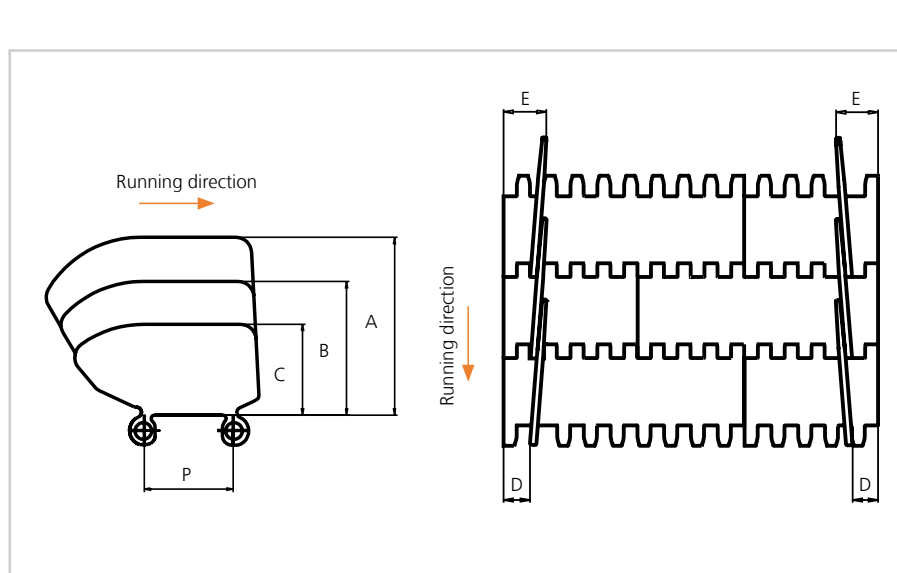
uni MPB Side Guard
Dimensions

	mm	in.
A	101.7	4.00
B	76.4	3.00
C	50.9	2.00
D*	16.0	0.63
E	32.0	1.26
P	50.8	2.00

* 34.0 mm (1.34 in.) combined with Product Support.

Increment: 8.4 mm (0.33 in.).

Note: Side Guards can not be positioned on top of G and N cones.

Standard Materials, Colors and Dimensions

Height		Standard materials & colors	
mm	in.	PE-I	PP-I
50.8	2.00		W
76.2	3.00	B	B
101.6	4.00	N	W B

Note: Backflex radius when side guards are used: 200 mm (7.9 in.).

Pitch 63.5 mm (2.50 in.)



uni X-MPB – the strongest hygienic belt for the food industry

The uni X-MPB is part of the cleanable uni MPB series used mainly in various food applications. The 2.5 in. pitch, straight running belt has the highest tensile strength and impact resistance among the food belts available in the uni-chains product range.

The uni X-MPB belt has proven to be a better belt in several industries/applications:

- Meat applications (beef & pork) including deboning lines, fat/trim lines, cutting lines, offal lines, evisceration lines and elevator/incline conveyors
- Poultry applications including cage dumper lines, deboning lines, fat/trim lines, offal lines and elevator/incline conveyors
- Fruit & vegetable applications including elevators and inspection tables

Product features and operational benefits:

- Easy to clean with reduced downtime for cleaning
- Unique lockpin locking system providing with faster and simpler maintenance
- Unique sprocket engagement enabling higher product load and longer conveyors
- FDA approved materials and USDA accepted construction
- Strong and thick product supports allowing more load without breakage
- Impact resistance to withstand heavy objects falling onto the belt

Standard Selection

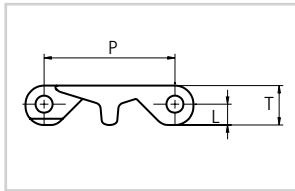
uni X-MPB C
Dimensional Sketch

uni X-MPB C
Dimensions

	mm	in.
L	10.1	0.40
P	63.5	2.50
T	19.1	0.75

- Straight running
- 63.5 mm (2.50 in.)
- $\varnothing 8$ mm (0.31 in.)
- Patent pending
- See page 11
- 75 mm (2.95 in.)
- See page 116
- See page 171

Accessories

- See page 115

Alternative

- PP W

Standard Materials and Colors

Type	Standard materials and colors	Standard pins materials and colors
uni X-MPB C	POM-DI W	PA6.6 N
	PE-I N	PA6.6 N
	PE-I B	PA6.6 N

Standard Bricklaid Belt Widths (See next for Single Link® widths)

mm	in.	mm	in.	mm	in.	mm	in.	mm	in.
75	3.0	679	26.7	1283	50.5	1887	74.3	2490	98.0
151	5.9	755	29.7	1358	53.5	1962	77.2	2566	101.0
226	8.9	830	32.7	1434	56.4	2037	80.2	2641	104.0
302	11.9	906	35.7	1509	59.4	2113	83.2	2717	107.0
377	14.9	981	38.6	1585	62.4	2188	86.2	2792	109.9
453	17.8	1056	41.6	1660	65.4	2264	89.1	2868	112.9
528	20.8	1132	44.6	1736	68.3	2339	92.1	2943	115.9
604	23.8	1207	47.5	1811	71.3	2415	95.1	3019	118.8

On above belt width values, the belt width tolerance on standard materials is +0/-0.4% at 23°C/73°F.

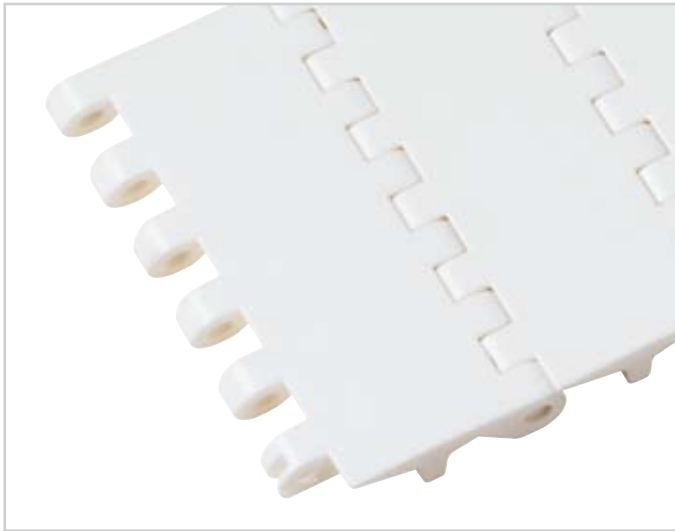
uni X-MPB Single Link®

uni X-MPB Single Link® is available in the following standard widths:

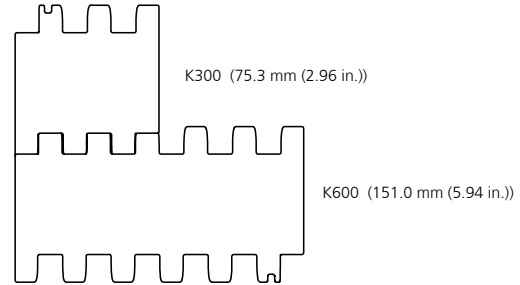
Belt Weights

Belt material	POM				PE	
	PP		PA6.6		PE	
Pin material	kg/m ²	lbf/ft ²	kg/m ²	lbf/ft ²	kg/m ²	lbf/ft ²
uni X-MPB C	14.5	2.96	14.7	3.00	10.0	2.05

Permissible Tensile Strength

Belt material	POM				PE	
	PP		PA6.6		PE	
Pin material	N/m	lbf/ft	N/m	lbf/ft	N/m	lbf/ft
uni X-MPB C	30000	2056	37500	2570	10000	685

Accessories | Product Support

uni X-MPB Product Support

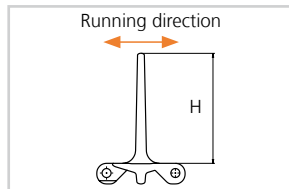
Dimensional Sketch

uni X-MPB Product Support

Standard Materials, Colors and Dimensions

H		Width			Standard materials & colors
mm	in.	Type	mm	in.	POM-DI
101.6	4.00	K600	151.0	5.94	W

Standard Bi-directional Sprockets for uni X-MPB

No. of teeth	Pitch diameter		Overall diameter		Hub diameter		Bore		Reference no.
	mm	in.	mm	in.	mm	in.	mm	in.	
6	126.0	4.96	124.2	4.89	70.0	2.76	ø18.0/40.0*	ø0.71/1.57*	803PA6XMPB06221N00
8	164.6	6.48	165.6	6.52	70.0	2.76	ø18.0/40.0*	ø0.71/1.57*	803PA6XMPB08221N00
10	203.9	8.03	206.6	8.13	120.0	4.72	ø40.0/70.0*	ø1.57/2.76*	8033XMPB10NBBR2
13	265.3	10.44	267.8	10.54	70.0	2.76	ø18.0/40.0*	ø0.71/1.57*	803PA6XMPB13221N00
					120.0	4.72	sq 38.1	sq 1.50	803PA6XMPB13221N001150S
							sq 63.5	sq 2.50	803PA6XMPB13221N001250S

* Minimum/maximum round bore.

Placement of Wearstrips and Sprockets

No. of teeth	Minimum B-dimension		Wearstrip distance A	
	mm	in.	mm	in.
6	72.5	2.85	44.9	1.77
8	92.0	3.62	66.6	2.62
10	111.7	4.40	87.6	3.45
13	141.7	5.58	118.7	4.67

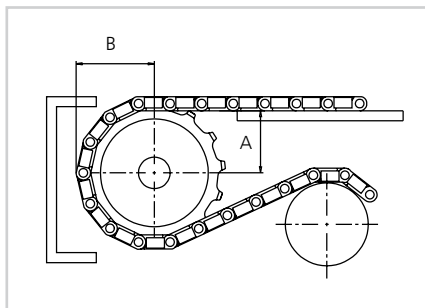

Other sprocket sizes are available upon request. Two-part sprockets are available upon request.

Pitch 63.5 mm (2.50 in.)



uni XLB – the strongest belt in the “uni-Verse”

uni XLB 2.5 in. pitch, straight running belt is designed for heavy duty conveyors. It is perfect belt to replace steel slat top chains, drag chains and other technologies used for high wear or heavy duty applications.

The uni XLB (Closed Top, Rough Top and V-Shape) belts have increased performance in the following industries/applications:

- Automotive applications including skid conveyors, manrider belts, car conveyors, leak tests
- Carwash applications including carwash and interior detailing areas
- Material handling applications including pallet handling and moving large paper rolls
- Meat (beef & pork) applications including shackle tables and gam tables

Product features and operational benefits:

- No lubrication required
- Reduced horsepower thanks to low friction materials
- Reduced downtime thanks to easy maintenance
- Reduced noise level
- Extreme wear and impact resistance
- Unique sprocket engagement enabling long conveyors with reduced pulsation
- Rough top surface reducing slippage and providing safe movements

Standard Selection



uni XLB C



uni XLB C Rough



uni XLB 15% Rough



uni XLB M2 V8

Dimensional Sketches

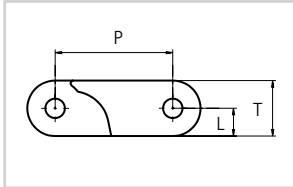

uni XLB C

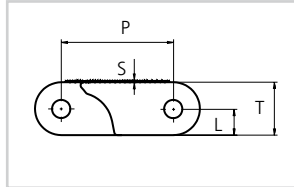

uni XLB C Rough

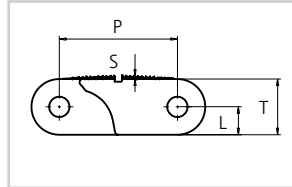

uni XLB 15% Rough

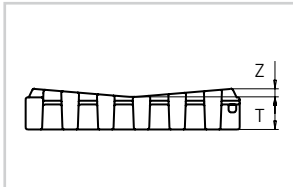

uni XLB M2 V8

- Straight running
- 63.5 mm (2.50 in.)
- \varnothing 10 mm (0.39 in.)
- Materials See page 11
- 100 mm (3.9 in.)
- See page 120
- See page 171

Alternative

PA6.6 N SS304

Dimensions

	mm	in.
L	15.0	0.59
P	63.5	2.50
S	1.5	0.06
T	30.0	1.18
Z	8.0	0.31

Standard Materials and Colors

Type	Standard materials and colors	Standard pin materials and colors	Standard lock materials and colors
uni XLB C	POM-NLAS K	PA6.6 N	PP D
	POM-NL K	PA6.6 N	PP D
uni XLB C Rough	POM-NLAS K	PA6.6 N	PP D
uni XLB 15% Rough	POM-NLAS K	PA6.6 N	PP D
uni XLB M2 V8	POM-D K	PA6.6 N	PP D

Standard Bricklaid Belt Widths

mm	in.	mm	in.	mm	in.	mm	in.	mm	in.	mm	in.	mm	in.	mm	in.
100	3.9	501	19.7	902	35.5	1302	51.3	1703	67.0	2104	82.8	2504	98.6	2905	114.4
200	7.9	601	23.7	1002	39.4	1402	55.2	1803	71.0	2204	86.8	2604	102.5	3005	118.3
301	11.8	701	27.6	1102	43.4	1503	59.2	1903	74.9	2304	90.7	2705	106.5	3105	122.3
401	15.8	801	31.5	1202	47.3	1603	63.1	2003	78.9	2404	94.6	2805	110.4	3205	126.2

On above belt width values, the belt width tolerance on standard materials is +0/-0.4% at 23°C/73°F.

uni XLB Single Link®

uni XLB Single Link® is available in the following standard widths:

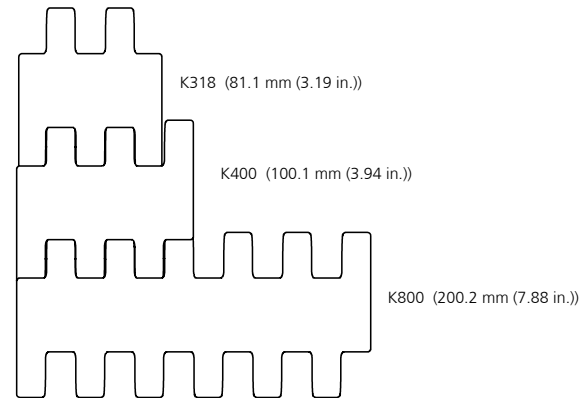
uni XLB Single Link® Belt Widths

Belt type and widths	K318 81.1 mm (3.19 in.)	K400 100.1 mm (3.94 in.)	K800 200.2 mm (7.88 in.)
uni XLB C	SLO	X	X
uni XLB C Rough		X	X
uni XLB 15% Rough		X	X
uni XLB M2 V8			X

SLO = Single Link only

Belt Weights

Belt material	POM			
	PA6.6		SS	
Pin material	kg/m ²	lb/ft ²	kg/m ²	lb/ft ²
uni XLB	31.0	6.35	40.8	8.36
uni XLB M2 V8	33.9	6.94	42.3	8.66

Permissible Tensile Strength

Belt material	POM			
	PA6.6		SS	
Pin material	N/m	lbf/ft	N/m	lbf/ft
uni XLB	90000	6210	100000	6900

Standard Bi-directional Sprockets for uni XLB

No. of teeth	Pitch diameter		Overall diameter		Hub diameter		Bore		Reference no. plastic
	mm	in.	mm	in.	mm	in.	mm	in.	
10	205.5	8.09	202.6	7.98	70.0	2.76	ø18.0/60.0*	ø0.71/2.36*	733PA6XLB10221N00
							sq 38.1	sq 1.50	733PA6XLB10221N00I150S
							sq 40.0	sq 1.57	733PA6XLB10221N01M040S
					100.0	3.94	ø41.0/90.0*	ø1.3/3.54*	733PA6XLB10221LG01
							sq 63.5	sq 2.50	733PA6XLB10221N00I250S
							sq 50.8	sq 2.00	733PA6XLB10221N00I200S
155	6.10	sq 60.0	sq 2.36	733PA6XLB10221N00M060S					
		sq 90.0	sq 3.54	733PA6XLB10221N00M090S					
13	265.3	10.44	264.4	10.41	235	9.25	ø18.0/200.0*	ø0.71/7.87*	733PA6XLB13221N00
					135	5.31	sq 76.2	sq 3.00	733PA6XLB13221LG00I300S
15	305.4	12.02	305.9	12.04	150	5.91	ø70.0/250.0*	ø2.76/9.84*	733PA6XLB15221N00
							sq 63.5	sq 2.50	733PA6XLB15221N00I250S
					150.0	5.91	sq 90.0	sq 3.54	733PA6XLB15221LG00M090S
							195.0	7.68	sq 120.0
220.0	8.66	sq 140.0	sq 5.51	733PA6XLB15221LG00M140S					
20	405.9	15.98	407.1	16.03	360	14.17	ø70.0/350	ø2.76/13.78	733PA6XLB20221N00
							sq 38.1	sq 1.50	733PA6XLB20221N00I150S
							sq 50.8	sq 2.00	733PA6XLB20221N00I200S
							sq 63.5	sq 2.50	733PA6XLB20221N00I250S
							sq 40.0	sq 1.57	733PA6XLB20221N00M040S
sq 60.0	sq 2.36	733PA6XLB20221N00M060S							

* Minimum/maximum round bore.

Placement of Wearstrips and Sprockets

No. of teeth	Minimum B-dimension		Wearstrip distance A	
	mm	in.	mm	in.
10	117.7	4.63	82.7	3.26
13	147.7	5.81	113.8	4.48
15	168.0	6.61	134.7	5.30
20	218.0	8.58	185.5	7.30

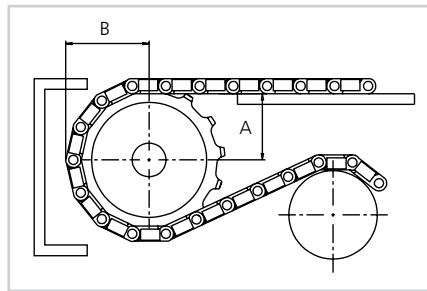

Other sprocket sizes are available upon request.

Two-part sprockets are available upon request.



Width of sprockets: 33.0 mm (1.30 in.)
Tooth width: 16.0 mm (0.63 in.)
Standard material: PA6

Max. Load per Sprocket

	N	lbf
uni XLB	12000	2700

Accessories | Product Support | Car Pusher

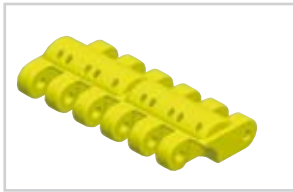

uni XLB Product Support



uni XLB Car Pusher

Dimensional Sketches

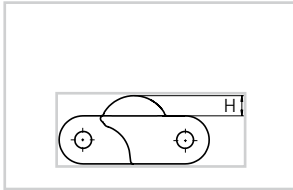

uni XLB Product Support

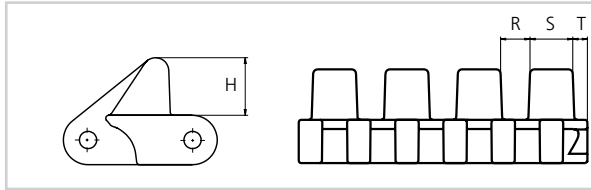

uni XLB Car Pusher

Dimensions

	mm	in.
R	18.1	0.71
S	32.0	1.26
T	9.0	0.35

Standard Materials, Colors and Dimensions

Style	H		Width			Standard materials & colors	
	mm	in.		mm	in.	POM-DK	POM-D
uni XLB Product Support	12.5	0.49	K800	199.6	7.86		Y
uni XLB Car Pusher	35.0	1.38	K800	199.6	7.86	O	

Pitch 25.4 mm (1.00 in.)



uni Flex ASB

This new generation of 1 inch pitch radius belts with or without hold down tabs in combination with a flat or curved surface offers a unique patent design providing a very strong radius belt. This new generation is easier to clean and combined with POM-D material, it has good release characteristics. The increased lateral stability allows fewer support strips than normal, where the beveled edges facilitates side way loading. Furthermore, the curved surface of the uni Flex ASB CS belt offers a reduced contact area of 10% and a smooth transfer. And in combination with a 9 tooth sprocket it forms a circle allowing a scraper against the belt. The uni Flex ASB is a proven belt in spiral applications.

The uni Flex ASB Series increases performance in the following industries and applications:

- Bakery industry including dough transport, cooling lines, internal transport, metal detectors and packaging lines
- Seafood applications including tray packing lines
- Meat & poultry applications including packaging lines
- Spiral applications as proofing and freezing of croissants, cooling and resting

Product features:

- Improved strength - 60% higher than previously, so longer conveyors are possible
- Standard POM-D material containing a self-lubricating component, improving non-stick characteristics and reducing friction
- Easy to clean due to improved hygienic design of the hinges
- Efficient product transfer and less product contact area (efficient cooling) with the curved surface type
- Less support strips due to increased lateral stability

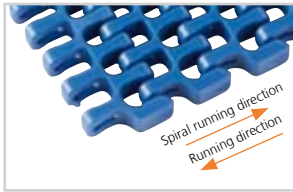
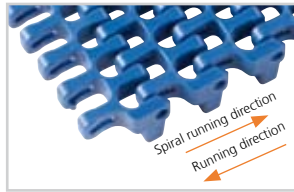
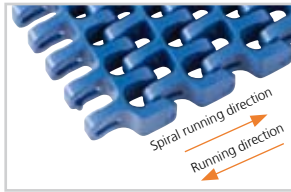
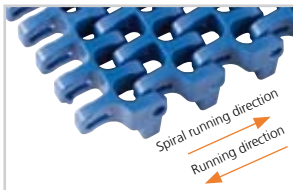
Standard Selection

uni Flex ASB
Surface opening 43%

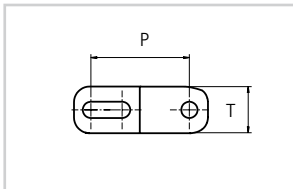
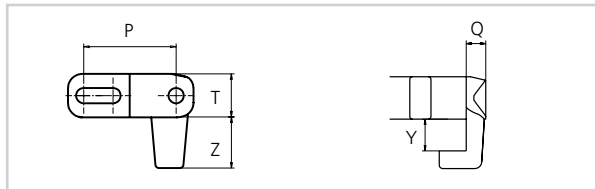
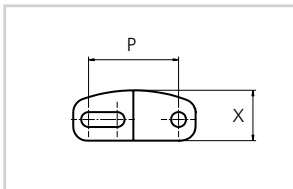
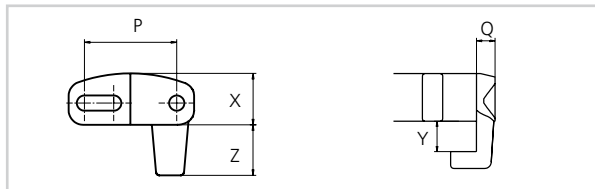
uni Flex ASB T
Surface opening 43%

uni Flex ASB CS
Surface opening 43%

uni Flex ASB CS T
Surface opening 43%

Min. inside radius 2.2 x belt width for all four types.

Dimensional Sketch

uni Flex ASB

uni Flex ASB T

uni Flex ASB CS

uni Flex ASB CS T

- Side flexing
- 25.4 mm (1.00 in.)
- Patent pending
- See page 11
- 25.0 mm (0.98 in.)
- See page 126
- See page 171

Accessories

- See page 125

Dimensions

	mm	in.
Q	5.5	0.20
P	25.4	1.00
T	12.0	0.47
X	14.2	0.56
Y	9.0	0.35
Z	14.0	0.55

Standard Materials and Colors

Type	Standard materials and colors	Standard pin materials and colors
uni Flex ASB	POM-D W	PA6.6 B
	POM-D B	PA6.6 B
	PP G	PA6.6 W
uni Flex ASB T	POM-D B	PA6.6 B
uni Flex ASB CS	POM-D W	PA6.6 B
	POM-D B	PA6.6 B
uni Flex ASB CS T	POM-D B	PA6.6 B

Standard Bricklaid Belt Widths

mm	in.	mm	in.	mm	in.	mm	in.
301	11.9	607	23.9	913	35.9	1219	48.0
378	14.9	684	26.9	990	39.0	1296	51.0
454	17.9	760	29.9	1066	42.0	1372	54.0
531	20.9	837	32.9	1143	45.0	1449	57.0

On above belt width values, the belt width tolerance on standard materials is +0/-0.4% at 23°C/73°F.

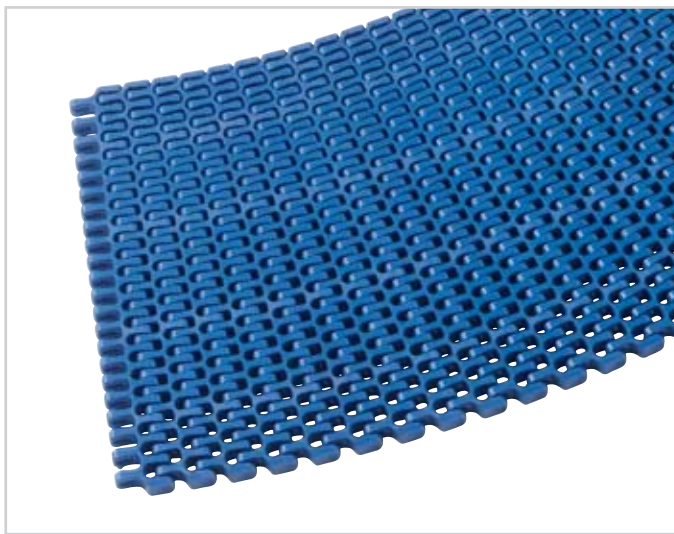
uni Flex ASB Single Link®

uni Flex ASB Single Link® is available in the following standard widths:

K1200 (301.1 mm (11.85 in.))

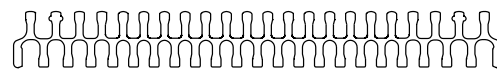

The both link is split in two and used as the outer part of the belt.

K1200 (306.0 mm (12.05 in.))

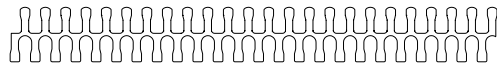

The center module are used in the middle of the belt.

uni Flex ASB T

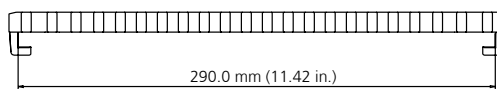
Standard Single Link® widths

Belt type and widths	K1200 Both 301.1 mm (11.85 in.)	K1200 Center 306.0 mm (12.05 in.)
uni Flex ASB	X	X
uni Flex ASB T	X	
uni Flex ASB CS	X	X
uni Flex ASB CS T	X	

Max. Permissible Load in Curve

Belt material	Belt width	POM		PP	
		PA6.6		PP	
Pin material	in.	N	lbf	N	lbf
uni Flex ASB T CS CS T	6 in. ≤ W < 12 in.	1200	270	720	162
uni Flex ASB T CS CS T	12 in. ≤ W < 18 in.	1600	360	960	216
uni Flex ASB T CS CS T	W > 18 in.	2040	459	1224	275

Max. Permissible Load in Straight Sections

Belt material	POM		PP	
	PA6.6		PP	
Pin material	N/m	lbf/ft	N/m	lbf/ft
uni Flex ASB T CS CS T	18800	1297	12500	863

Belt Weights

Belt material	POM		PP	
Pin material	PA6.6		PP	
	kg/m ²	lb/ft ²	kg/m ²	lb/ft ²
uni Flex ASB T	8.2	1.68	5.2	1.06
uni Flex ASB CS CS T	8.3	1.70	-	-

Design Guidelines

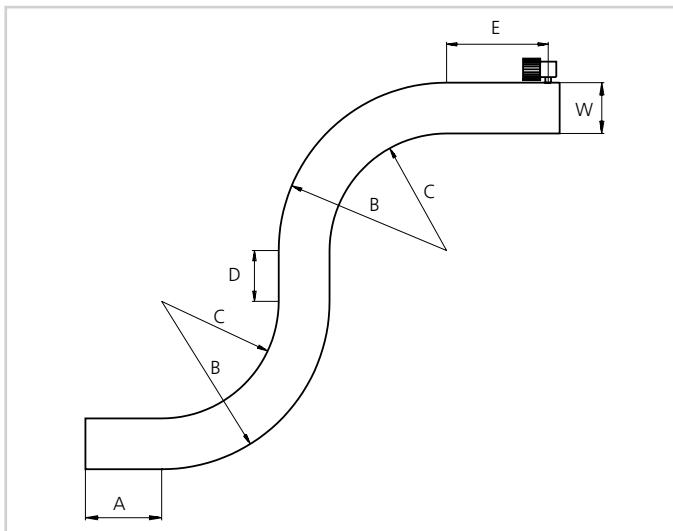

	Radius 2.2
A	min. 1.5 x W
B	min 3.2 x W
C	min 2.2 x W
D	min 2 x W
E	min 2 x W, min. 450 mm (17.7 in.)
W	Belt width

For min. conveyor dimensions please refer to sketch and diagram.

Accessories | Lane Divider



Lane Divider

Dimensions

	mm	in.
H	25.4	1.00

Standard Materials and Colors

POM-D	B	W
-------	----------	---

Standard Sprockets

No. of teeth	Pitch diameter		Overall diameter		Hub diameter		Bore		Reference no. plastic
	mm	in.	mm	in.	mm	in.	mm	in.	
7	58.5	2.30	58.0	2.28	0	0	ø18.0/25.0	ø0.71/0.98	653PA6FASB07221N00
9	74.3	2.93	75.0	2.95	0	0	ø18.0/30.0	ø0.71/1.18	6653PA6FASB09221N00
							sq 25.4	sq 1.00	653PA6FASB09221N00I100S
12	98.1	3.86	100.0	3.94	0	0	ø18.0/40.0	0.71/1.57	653PA6FASB12221N00
							sq 38.1	sq 1.50	653PA6FASB12221N00I150S
15	122.2	4.81	124.6	4.91	0	0	ø18.0/70.0	ø0.71/2.76	653PA6FASB15221N00
							sq 38.1	sq 1.50	653PA6FASB15221N00I150S
							sq 40.0	sq 1.57	653PA6FASB15221N00M040S
18	146.3	5.76	149.3	5.88	0	0	ø18.0/70.0	ø0.71/2.76	653PA6FASB18221N00
							sq 38.1	sq 1.50	653PA6FASB18221N00I150S
							sq 40.0	sq 1.57	653PA6FASB18221N00M040S

Placement of Wearstrips and Sprockets

No. of teeth	Minimum B-dimension		Wearstrip distance A	
	mm	in.	mm	in.
7	37.3	1.47	19.5	0.77
9	45.1	1.78	28.0	1.10
12	57.1	2.25	40.5	1.59
15	69.1	2.72	52.9	2.08
18	81.1	3.19	65.2	2.57

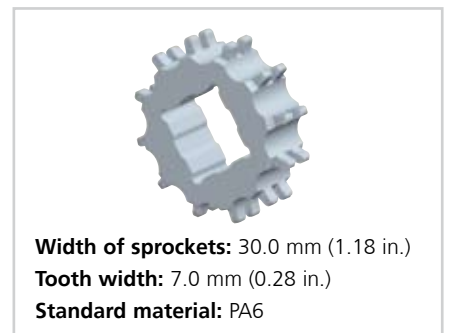
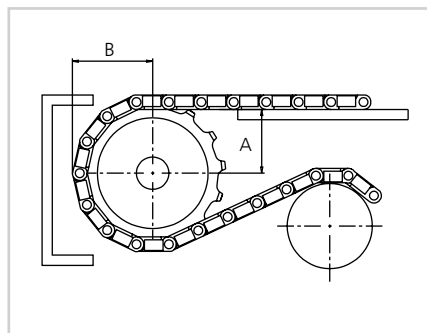

Other sprocket sizes are available upon request.

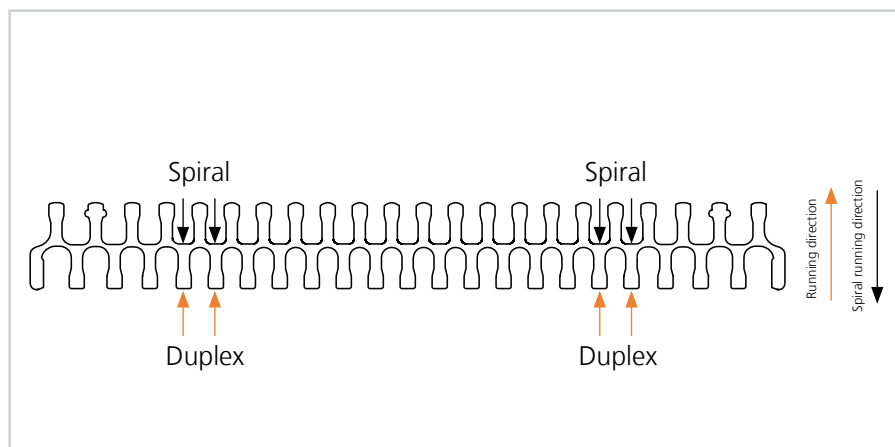
Placing of Sprockets

Max. Load per Sprocket

Belt material	POM		PP	
	N	lbf	N	lbf
uni Flex ASB T CS CS T	2000	450	1100	247

Pitch 25.4 mm (1.00 in.)



uni Flex SNB – strong and tight radius side flexing belt

uni Flex SNB 1 in. pitch is created to optimize throughput in high volume operations with space limitations. The belt has unique strength and side flexing characteristics and is used in many different applications.

The uni Flex SNB belt has increased performance in the following industries/applications:

- Meat & poultry applications including tray pack conveyors, box/tote handling, freezers infeed/outfeed, low tension spirals and other side flexing applications
- Fruit & vegetable applications including filling lines, canning lines and incline/decline applications
- Bakery applications including cooling lines, pan handling, proofers and oven infeed and takeaway
- Beverage applications including case conveyors, shrink tunnels and incline/decline applications
- Can manufacturing applications including mass handling, transfer conveyors and palletizers infeed conveyors

Product features and operational benefits:

- 180 degree high speed side flexing applications
- High temperature and wear resistance
- Tight radius applications with reduced space requirements
- Unique locking system (no pin walking or pins coming out)
- Unique radius top surface for minimum product contact and less friction
- Reinforced stainless steel links for higher strength, speed or load

Standard Selection

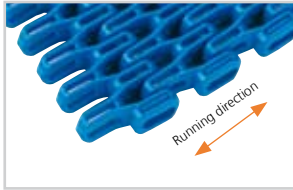

uni Flex SNB L
Surface opening 55%

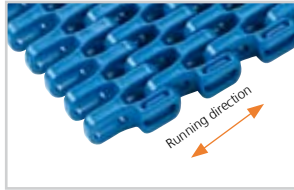

uni Flex SNB C
Surface opening 47%



uni Flex SNB CR
Surface opening 47%

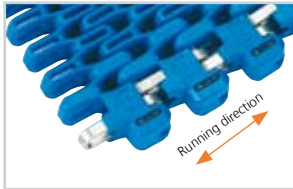

uni Flex SNB W
Surface opening 55%



uni Flex SNB WT
Surface opening 55%

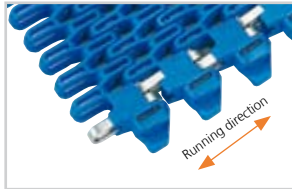

uni Flex SNB WO
Surface opening 55%



uni Flex SNB CR Rubber Top
Surface opening 47%



uni Flex SNB C Rubber Top
Surface opening 47%

Indent
uni Flex SNB CR Rubber Top is 26.5 mm (1.04 in.).
uni Flex SNB C Rubber Top is 7.0 mm (0.28 in.).
uni Flex SNB L Rubber Top is available without indent.

Dimensional Sketches

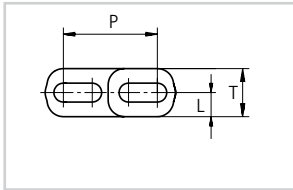

uni Flex SNB L
uni Flex SNB W
uni Flex SNB WO

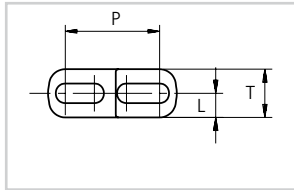

uni Flex SNB C
uni Flex SNB CR

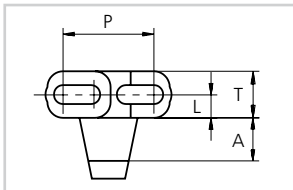

uni Flex SNB WT

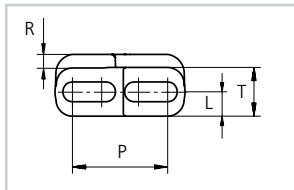

uni Flex SNB Rubber Top

- Side flexing
- 25.4 mm (1.00 in.)
- \varnothing 5 mm (0.20 in.)
- Patented
- See page 11
- 25 mm (1.0 in.)
- See page 135
- See page 171
- 03 K** **03 N** See page 16

Alternative

- PP W** **SS304** **SS316**

Dimensions

	mm	in.
A	12.0	0.47
L	6.5	0.26
P	25.4	1.00
R	3.0	0.12
T	13.0	0.51

uni Flex SNB L: Standard radius. Min. inside radius 2.3 x belt width. 55% open area for optimal airflow/cooling.

uni Flex SNB C: Standard radius. Min. inside radius 2.3 x belt width. 47% open hygienic solid grid surface.

uni Flex SNB CR: Tight radius. Min. inside radius 1.6 x belt width. 47% open hygienic solid grid surface.

uni Flex SNB W: Standard radius (2.3 x W) fitted with reinforcement links and steel pins. Integral molded edge wearpart.

uni Flex SNB WT: Standard radius (2.3 x W) fitted with cover links and PA6.6 pins or with reinforcement links and steel pins. Integral molded edge wearpart. Integral underside tab (S-Tab).

uni Flex SNB WO: Standard radius (2.3 x W) fitted with reinforcement links and steel pins. Integral outer edge tab system. Enables transportation of products wider than the belt.

Standard Materials and Colors

Type	Standard materials and colors		Standard pin materials and colors
uni Flex SNB L	POM-D	W	PA6.6 N
	POM-D	B	PA6.6 B
	PP	W	PA6.6 N
	PP	B	PA6.6 B
	PA6.6	B	PA6.6 B
	PA6.6	W	PA6.6 N
uni Flex SNB C/CR	POM-D	W	PA6.6 N
	POM-D	B	PA6.6 B
	PP	W	PA6.6 N
	PP	B	PA6.6 B
	PA6.6	B	PA6.6 B
	PA6.6	W	PA6.6 N
uni Flex SNB W	POM-D	W	SS304
	POM-D	B	SS304
	PP	W	SS304
	PP	B	SS304
	PA6.6	B	SS304
	PA6.6	W	SS304
uni Flex SNB WT	POM-D	W	SS304 or PA6.6 N
	POM-D	B	SS304 or PA6.6 B
	PP	W	SS304 or PA6.6 N
	PP	B	SS304 or PA6.6 B
	PA6.6	B	SS304 or PA6.6 B
	PA6.6	W	SS304 or PA6.6 N
uni Flex SNB WO	POM-D	W	SS304
	POM-D	B	SS304
	PP	W	SS304
	PP	B	SS304
	PA6.6	B	SS304
	PA6.6	W	SS304
uni Flex SNB Rubber Top	PP	B + 03 K	PA6.6 B
	PP	W + 03 N	PA6.6 N

For all uni Flex SNB L types: Lockingplate | Wearparts | O-Tab
Standard materials and colors

 Lockingplates **PP** W B

 Wearparts and O-Tab **PA6.6** W B

For high speed and/or abrasive applications:

 Wearpart and O-Tab **POM-DK** N

For uni Flex SNB | uni Flex SNB W | uni Flex SNB WT | uni Flex WO

Outer modules are always in PA6.6. On belt widths wider than 235 mm (9 in.)

Belt may be combined with any of above L or CM links in the middle.

 Reinforcement links: **SS304**
uni Flex SNB Cover Link

Standard materials and colors
PA6.6 W B

Standard Modular Widths for uni Flex SNB L (W_L)

mm	in.	mm	in.	mm	in.	mm	in.	mm	in.
76*	3.0*	304	12.0	532	20.9	760	29.9	988	38.9
152*	5.9*	379	14.9	608	23.9	836	32.9	1065	41.9
228**	9.0	456	18.0	684	26.9	912	35.9	-	-

Non standard cut widths are possible in multiples of 12.7 mm (0.50 in.). To find the belt widths for other uni Flex SNB tracking systems and belt types, please use formulas below. On above belt width values, the belt width tolerance on standard materials is +0/-0.4% at 23°C (73° F).

* Note: These belt widths are only available for uni Flex SNB L and uni Flex SNB C.

** uni Flex SNB W, uni Flex SNB WO, uni Flex SNB WT are only standard in PA6.6 material.

uni Flex SNB C, uni Flex SNB CR, uni Flex SNB L are closed with latching plates in both sides: $W = W_L$.

uni Flex SNB C | uni Flex SNB CR: $W = W_L$

uni Flex SNB L or uni Flex SNB C | uni Flex SNB C with wearpart both sides: $W = W_L + 2 \times 3 \text{ mm (2 x 0.12 in.)}$

For wearpart /O-Tab one side: $1 \times 3 \text{ mm (1 x 0.12 in.)}$

uni Flex SNB L uni Flex SNB C | uni Flex SNB CR with O-Tab both sides: $W = W_L + 2 \times 3 \text{ mm (2 x 0.24 in.)}$

For wearpart /O-Tab one side: $1 \times 3 \text{ mm (1 x 0.12 in.)}$

uni Flex SNB W | uni Flex SNB WO or uni Flex SNB WT both sides: $W = W_L + 2 \times 3 \text{ mm (2 x 0.12 in.)}$

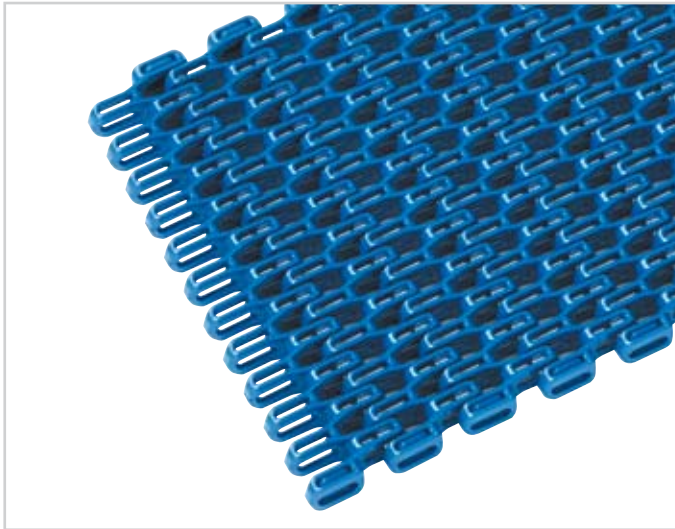
uni Flex SNB Link

uni Flex SNB L Single Link® is available in the following standard widths:

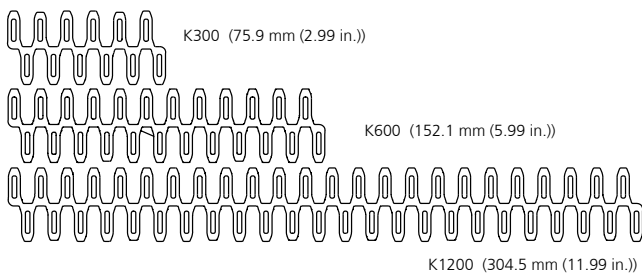

uni Flex SNB C Single Link® is available in the following standard widths:

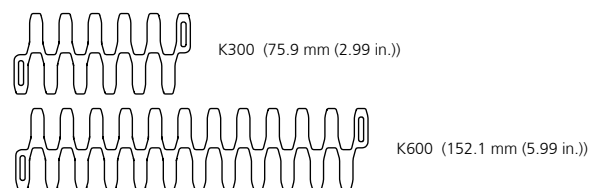

uni Flex SNB Link®

uni Flex SNB W Single Link® is available in the following standard widths:

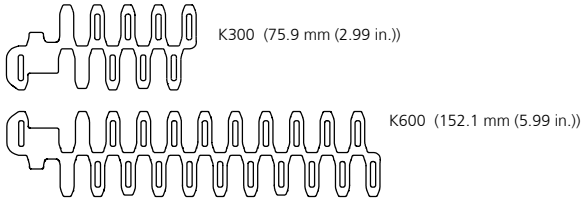

uni Flex SNB CR Single Link® is available in the following standard widths:

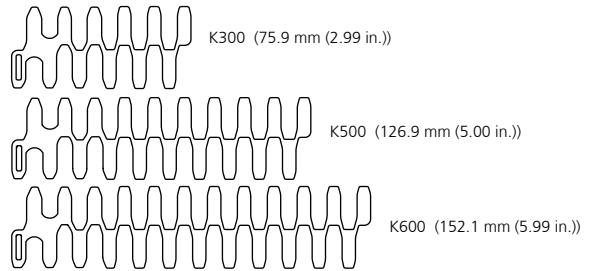

uni Flex SNB WT Single Link® is available in the following standard widths:

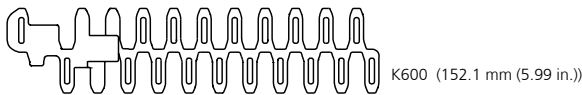

uni Flex SNB WO Single Link® is available in the following standard widths:

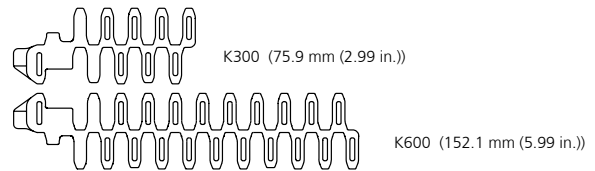
uni Flex SNB Single Link® Widths

Belt type and widths	K300 75.9 mm (2.99 in.)	K500 126.9 mm (5.00 in.)	K600 152.1 mm (5.99 in.)	K1200 304.5 mm 11.99 in.)
uni Flex SNB L	X		X	X
uni Flex SNB L Rubber Top	X		X	
uni Flex SNB C	X		X	
uni Flex SNB C Rubber Top	X		X	
uni Flex SNB CR*	X	X	X	
uni Flex SNB W**	X		X	
uni Flex SNB WT***			X	
uni Flex SNB WO****	X		X	

* Not available as Single Link.

** Has integrated wearpart.

*** Has integrated underside tab (S-Tab).

**** Has integrated outer edge tab system (O-Tab).

uni Flex SNB Program

Belt type	Material	Hinge design	Flex ratio/min inside radius
uni Flex SNB L	all plastic	open hinge	2.3
uni Flex SNB C	all plastic	closed hinge	See below
uni Flex SNB CR	all plastic	closed hinge	1.6**
uni Flex SNB W	plastic and steel	open hinge	2.3
uni Flex SNB WT	all plastic or plastic and steel	open hinge	2.3
uni Flex SNB WO	plastic and steel	open hinge	2.3

Please, refer to this diagram for the material combinations, surface openings and turning radii of the five different uni Flex SNB types.

Minimum straight section from idler end and first curve 1.5 x belt width (W).

Minimum straight section between left and right curves: 2.0 x belt width (W).

Inner curve radius = Flex ratio x belt width.

Minimum straight section from last curve to drive section 2.0 x belt width (W).

* K300 Single Link® Flex ratio = 1.9 and K600 Single Link® Flex ratio = 1.8.

** Widths below 9 in. (228 mm): 1.5

Max. Permissible Load in Curve

	Belt material	POM/PA6.6		PP	
	Pin material	N	lbf	N	lbf
uni Flex SNB L uni Flex SNB C uni Flex SNB CR	SS	600	135	600	135
uni Flex SNB L uni Flex SNB C uni Flex SNB CR	PA6.6	1000	225	600	135

Max. Permissible Load in Curve

	Belt material	POM/PA6.6		PP	
	Pin material	N	lbf	N	lbf
uni Flex SNB W uni Flex SNB WO uni Flex SNB WT	SS	600	135	600	135
uni Flex SNB W uni Flex SNB WO uni Flex SNB WT	PA6.6**	1000	225	600	135
uni Flex SNB W uni Flex SNB WO uni Flex SNB WT	SS + RL*	3300	742	-	-

* RL = Reinforcement link

** Only standard in uni Flex SNB WT.

Max. Permissible Load in Straight Sections

	Belt material	POM/PA6.6		PP	
	Pin material	N/m	lbf/ft	N/m	lbf/ft
uni Flex SNB L uni Flex SNB C uni Flex SNB CR uni Flex SNB W uni Flex SNB WO uni Flex SNB WT	PA6.6 or SS	30000	2055	15000	1028

Load Capacity per Reinforcement Link

	N/pcs	lbf/pcs
uni Flex SNB	3300	742

The use of belts with the SS reinforcement IPitch control links in blanchers, cookers and other high temperature applications will reduce belt elongation due to temperature by more than 90%. This will simplify the belt take-up system and reduce maintenance.

Note: Reinforcement links require the use of SS pins.

Belt Tracking og Control Systems

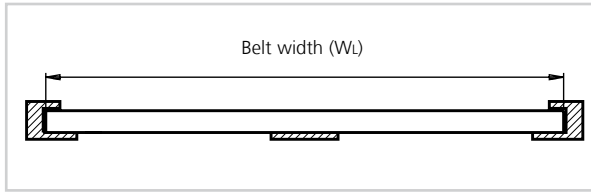
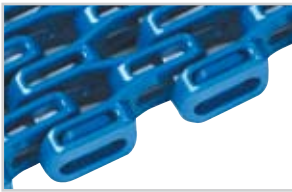

Basic belt types can be combined with the belt tracking and control systems below to enhance performance. Basic belt types can be combined with the belt tracking and control systems below to enhance performance.

uni Flex SNB L
Standard

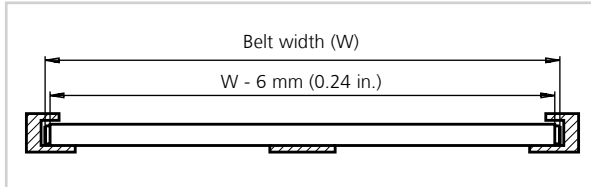

Wearpart system made of heat and wear re-sistant nylon to reduce the friction between belt edge and wearstrip. Only this part needs to be replaced when it has been worn out, not the entire belt.

Wearpart

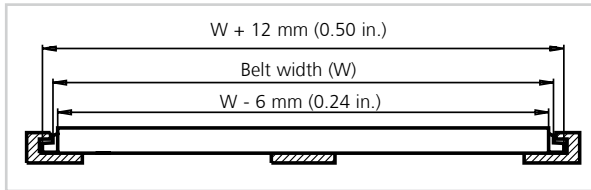

Outer edge tab system made of heat and wear resistant nylon to reduce the friction between belt edge and wearstrip. Using a slotted wearstrip, the O-Tab will track the belt and allow the conveyed products to be wider than the belt.

O-Tab

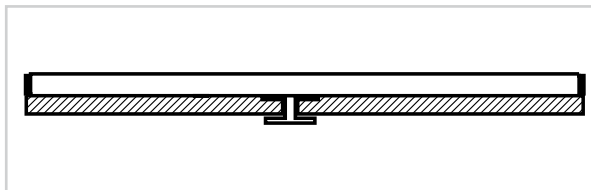

Intermediate tabs are placed on the bottom side of the belt to hold it down on incline conveyors. The intermediate tabs will fit anywhere across the belt bottom and at pitch multiples of 12.7 mm (0.50 in.).

I-Tab

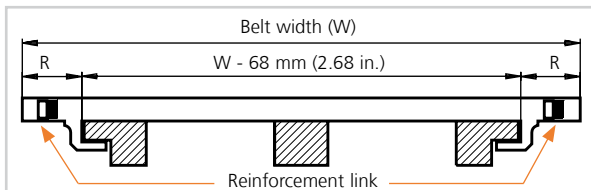

Side tab for holding the belt down. Normally used for wide belts. With S-Tabs, the radial forces in the curve are transferred to the outside radius (uni Flex SNB-WT).
R = 34.0 mm (1.34 in.).

S-Tab

Note: When using S Tabs, please verify sufficient clearance to the shaft. Max. shaft diameter = Sprocket pitch diameter - 50.8 mm (2.00 in.). When using square shafts, please verify that the diagonal does not exceed max. diameter.
Example: Sprocket z = 10: Max. shaft diameter 82.2 - 50.8 = $\varnothing 31$ mm (3.24 - 2.00 = $\varnothing 1.2$ in.).

Belt type	Belt tracking and control combination			
	Wearpart	O-Tab	S-Tab	I-Tab
uni Flex SNB L	+	+	-	+
uni Flex SNB C uni Flex SNB CR	+	+	-	-
uni Flex SNB W	✓	-	-	+
uni Flex SNB WT	-	-	✓	+
uni Flex SNB WO	-	✓	-	+

✓ Standard + Optional - Unavailable

Belt Weights for uni Flex SNB L

Belt material	POM		PP		PA6.6	
Pin material	kg/m ²	lb/ft ²	kg/m ²	lb/ft ²	kg/m ²	lb/ft ²
PA6.6	6.9	1.41	4.8	0.98	5.8	1.19
SS	12.1	2.48	10.0	2.05	11.0	2.25

Belt Weights for uni Flex SNB C | uni Flex SNB CR

Belt material	POM		PP		PA6.6	
Pin material	kg/m ²	lb/ft ²	kg/m ²	lb/ft ²	kg/m ²	lb/ft ²
PA6.6	7.7	1.58	5.4	0.98	6.4	1.31
SS	12.9	2.64	10.2	2.09	11.6	2.38

Belt Weights for uni Flex SNB W

Belt material	POM		PP		PA6.6	
Pin material	kg/m ²	lb/ft ²	kg/m ²	lb/ft ²	kg/m ²	lb/ft ²
PA6.6	7.3	1.50	5.1	1.04	6.0	1.23
SS	12.5	2.56	10.3	2.11	11.2	2.29

Belt Weights for uni Flex SNB WT

Belt material	POM		PP		PA6.6	
Pin material	kg/m ²	lb/ft ²	kg/m ²	lb/ft ²	kg/m ²	lb/ft ²
PA6.6	7.6	1.56	5.3	1.09	6.3	1.29
SS	12.8	2.62	10.5	2.15	11.5	2.36

Belt Weights for uni Flex SNB WO

Belt material	POM		PP		PA6.6	
Pin material	kg/m ²	lb/ft ²	kg/m ²	lb/ft ²	kg/m ²	lb/ft ²
PA6.6	7.5	1.54	5.3	1.09	6.2	1.27
SS	12.7	2.60	10.5	2.15	11.4	2.34

Standard Sprockets

No. of teeth	Pitch diameter		Overall diameter		Hub diameter		Bore		Reference no. plastic
	mm	in.	mm	in.	mm	in.	mm	in.	
9	74.3	2.93	73.8	2.91	56.8	2.24	ø18.0/30.0*	ø0.71/1.18*	213PA6FSNB09211LG00
							sq 25.4	sq 1.00	2133FSNB0910INSQ
							sq 30.0	sq 1.18	213PA6FSNB09211N00M030S
10	82.2	3.24	82.2	3.24	65.2	2.57	ø18.0/40.0*	ø0.71/1.57*	213PA6FSNB10211N00
							sq 25.4	sq 1.00	213PA6FSNB10211N00I100S
							sq 30.0	sq 1.18	213PA6FSNB10211N00M030S
12	98.2	3.87	98.8	3.89	70.0	2.76	ø18.0/40.0*	ø0.71/1.57*	213PA6FSNB12211N00
							sq 38.1	sq 1.50	213PA6FSNB12211N00I150S
							sq 40.0	sq 1.57	213PA6FSNB12211N00M040S
15	122.2	4.81	123.5	4.86	70.0	2.76	ø18.0/40.0*	ø0.71/1.57*	213PA6FSNB15211N00
							sq 38.1	sq 1.50	213PA6FSNB15211N00I150S
							sq 40.0	sq 1.57	213PA6FSNB15211N00M040S
18	146.3	5.76	146.1	5.75	70.0	2.76	ø18.0/40.0*	ø0.71/1.57*	213PA6FSNB18211N00
							sq 38.1	sq 1.50	213PA6FSNB18211N00I150S
							sq 40.0	sq 1.57	213PA6FSNB18211N00M040S
19	154.3	6.07	156.2	6.15	70.0	2.76	ø18.0/40.0*	ø0.71/1.57*	213PA6FSNB19211N00
							sq 38.1	sq 1.50	213PA6FSNB19211N00I150S
							sq 40.0	sq 1.57	213PA6FSNB19211N00M040S

* Minimum/maximum round bore.

Placement of Wearstrips and Sprockets

No. of teeth	Minimum B-dimension		Wearstrip distance A	
	mm	in.	mm	in.
9	43.5	1.71	28.4	1.12
10	47.5	1.87	32.6	1.28
12	55.5	2.19	40.9	1.61
15	67.5	2.66	53.2	2.09
18	79.6	3.13	65.5	2.58
19	83.6	3.29	69.6	2.74

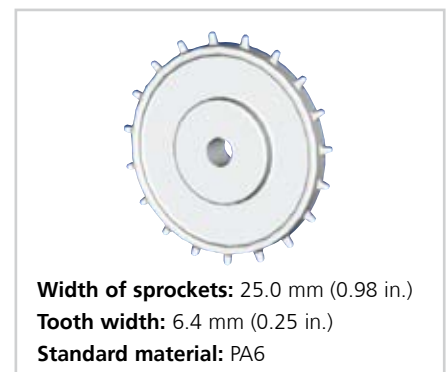
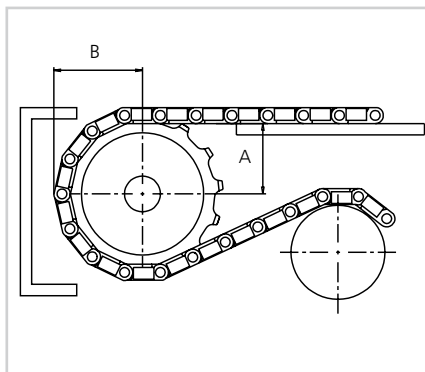

Other sprocket sizes are available upon request. Two-part sprockets are available upon request.

Max. Load per Sprocket

Belt material	POM or PA6.6		PP	
	N	lbf	N	lbf
uni Flex SNB	1200	270	850	191

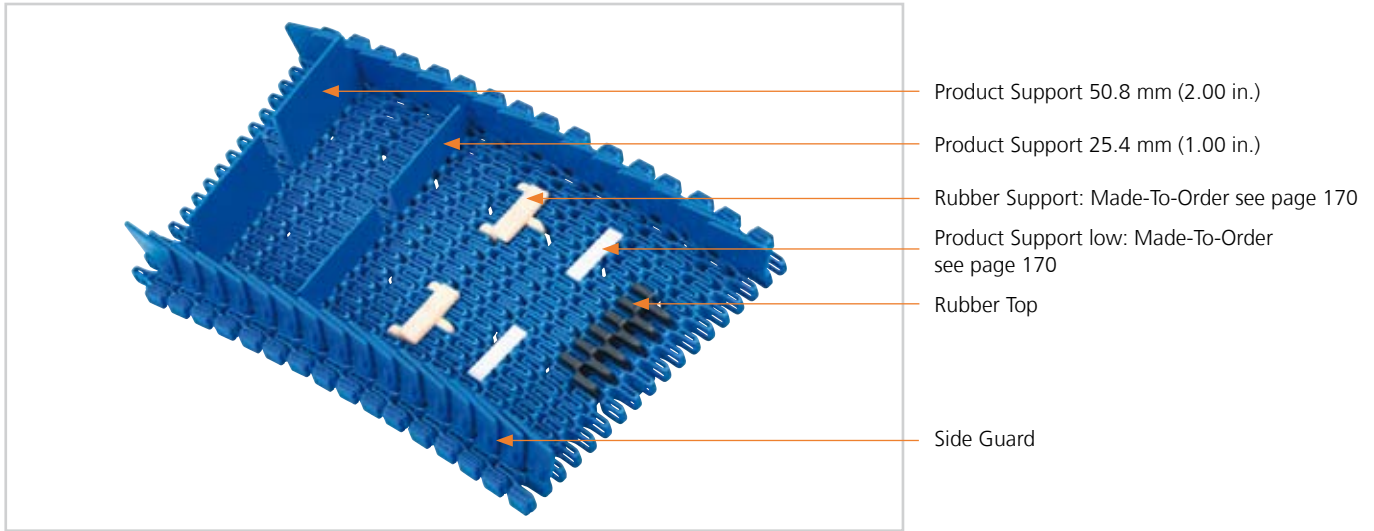
Accessories

Standard Materials and Colors

Style	Height		Width		Standard materials & colors		
	mm	in.	mm	in.	PA6.6	PP-I	PP
Side Guard	30.0	1.18	-	-		B	
Product Support	25.4	1.00	75.9	2.99	B		B
	50.8	2.00					

Belt Top Accessories

Belt type	Rubber Top	Side Guard	Product Support
uni Flex SNB L	+	+	+
uni Flex SNB C	+ ^{1/}	-	-
uni Flex SNB CR	+ ^{2/}	-	-
uni Flex SNB W	+ ^{3/}	+	+
uni Flex SNB WT	+ ^{3/}	+	+
uni Flex SNB WO	+ ^{3/}	+	+

+ = *Optional*

- = *Unavailable*

1/ Minimum indent from the side of the belt is 6.5 mm (0.26 in.).

2/ Minimum indent from the side of the belt is 26.5 mm (1.04 in.).

3/ Minimum indent from the side of the belt is 75.9 mm (2.99 in.).

For buildings patterns, please contact Ammeraal Beltech Modular.

Pitch 38.1 mm (1.50 in.)



uni Flex ONE – strong, cleanable and tight radius side flexing belt

uni Flex ONE 1.5 in. pitch is created to optimize throughput in high volume operations with space limitations. The belt is unique because of its pinless design and a higher tensile strength. No other side flexing belts in the market may compete with uni Flex ONE on straight.

The uni Flex ONE belt will increase performance in the following industries/applications:

- Meat & poultry applications including tray pack conveyors, box/tote handling, freezers infeed/outfeed and other side flexing applications
- Fruit & vegetable applications including side flexing and packaging lines
- Bakery applications including cooling lines, pan handling, proofers and oven infeed and takeaway
- Beverage applications including case conveyors and incline/decline applications
- Spiral applications including low and high tension spirals

Product features and operational benefits:

- High speed side flexing applications
- Tight radius applications providing reduced space requirements
- uni Snap Link® design (pinless) preventing no pin walking
- Unique safety top surface
- Edge Wearparts for higher speed and load
- Edge Roller Bearings for higher speed, load and no lubrication
- Integrated Wearparts for cleanable applications
- Easy maintenance with uni Snap Link® Design (pinless)

Standard Selection



uni Flex ONE O



uni Flex ONE EO



uni Flex ONE EW



uni Flex ONE ER



uni Flex ONE EOO

*Ammeraal Beltech recommends this travel direction. However, travel in both directions is possible.



Side flexing



38.1 mm (1.50 in.)



Patent pending



See page 11



50 mm (1.8 in.)



See page 145 and 146



See page 171



See page 147

Dimensional Sketches

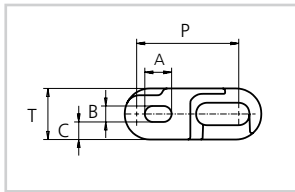

uni Flex ONE O (EO)

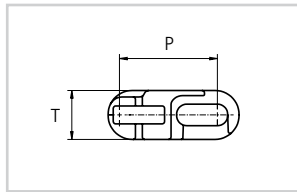

uni Flex ONE for EO | EOO | EW | ER

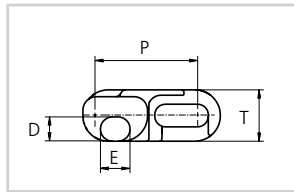

uni Flex ONE EOO

Exchangeable parts: O-Tabs (EO), Offset O-Tabs (EOO), Wearparts (EW), Edge Rollers (ER).

Standard Materials and Colors

Type	Standard materials and colors
uni Flex ONE	POM-SX W

Exchangeable O-Tab, wearpart in POM-DK: O

Dimensions

	mm	in.
A	10.0	0.39
B	5.9	0.23
C	6.6	0.26
D	9.0	0.35
E	11.0	0.43
P	38.1	1.50
T	19.1	0.75

uni Flex ONE O (O-Tab):

Using the uni Flex ONE with O-Tab and a slotted wearstrip, the O-Tab will allow the transported products to be wider than the belt. O-Tabs are molded into the belt to ensure cleanability and are preferred for direct food contact.

uni Flex ONE EO/EOO (Exchangeable O-Tab/ Exchangeable Offset O-Tab):

Exchangeable O-Tab system is made of heat and wear resistant

material to improve performance between the belt edge and the wearstrip. Using a slotted wearstrip the exchangeable O-Tab will track the belt and allow the transported products to be wider than the belt. Resists high curve load at increased speed.

uni Flex ONE EW (Exchangeable Wearpart):

Exchangeable Wearpart system is made of heat and wear resistant material to improve performance between the belt edge and the wearstrip. This Wearpart

can easily be replaced. Resists high curve load at increased speed.

uni Flex ONE ER (Exchangeable Edge Roller):

uni Flex ONE with Exchangeable Edge Rollers reduces friction in curves to a minimum making it very suitable for applications with many curves e.g. static spirals (non rotating drum) or high speed side flexing conveyors.

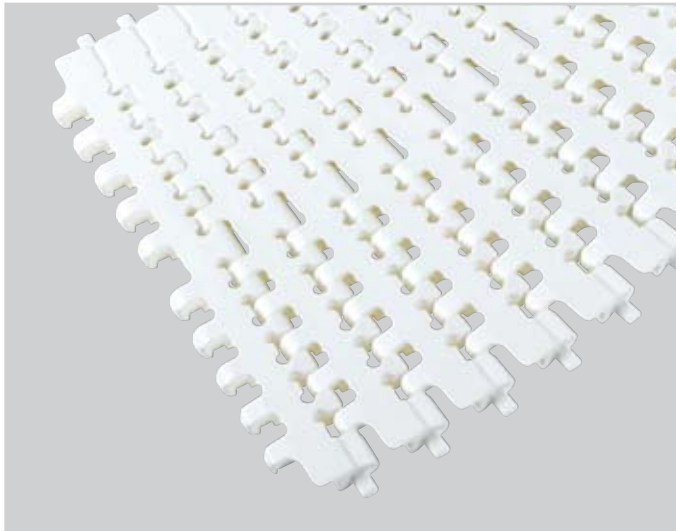
uni Flex ONE Single Link®

uni Flex ONE Single Link® is available in the following standard widths:

K750 190.5 mm (7.50 in.)

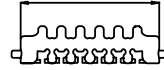

K1200 (304.8 mm (12.00 in.))

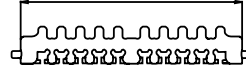

K1500 (381.0 mm (15.00 in.))

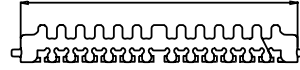

K2400 (609.6 mm (24.00 in.))

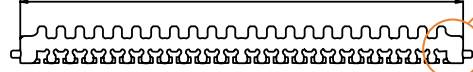
Standard Single Link® Belt Widths

Belt type and widths	K750	K1200	K1500	K2400
uni Flex ONE O	X	X	X	X
uni Flex ONE EW	X	X	X	X
uni Flex ONE EO/EOO	X	X	X	X
uni Flex ONE ER L/R*	X	X	X	X

* L/R = L (left)/R (right). When ordering, please specify Belt Edge Configuration on opposite side of edge roller (e.g. uni Flex ONE ER/EO = ER on left side and EO on right side - uni Flex ONE EW/ER = EW on left side and ER right side).

Permissible Tensile Strength

Assortment		Belt width W	Max. permissible load on straight section		Max. permissible load in curves at low speed*			
					UHMW PEHD 1000		Nylatron NSM	
					Size	N	lbf	N
uni Flex ONE	O	K750	2400	540	1800	405	2000	450
	EW				1800	405	2000	450
	EO/EOO				1800	405	2000	450
	ER				2000	450	2000	450
uni Flex ONE	O	K1200	4000	899	2700	607	3400	764
	EW				2700	607	3400	764
	EO/EOO				2700	607	3400	764
	ER				3400	764	3400	764
uni Flex ONE	O	K1500	6400	1439	2800	629	3500	787
	EW				2800	629	3500	787
	EO/EOO				2800	629	3500	787
	ER				3500	787	3500	787
uni Flex ONE	O	K2400	12000	2698	3200	719	3800	854
	EW				3200	719	3800	854
	EO/EOO				3200	719	3800	854
	ER				3800	854	3800	854

* Valid at 20° C (+ 68° F). Material for all types of uni Flex ONE: POM-SX.

Belt Weights

Assortment	POM				
	Size	mm	in.	kg/m	lb/ft
uni Flex ONE O	K750	190.5	7.50	2.5	1.68
uni Flex ONE EW				2.4	1.61
uni Flex ONE EO/EOO				2.5	1.68
uni Flex ONE ER-/L/R*				2.6	1.75
uni Flex ONE ER/ER				2.7	1.81
uni Flex ONE O	K1200	304.8	12.00	4.0	2.69
uni Flex ONE-EW				3.9	2.62
uni Flex ONE-EO/EOO				4.0	2.69
uni Flex ONE ER-/L/R*				4.1	2.76
uni Flex ONE ER/ER				4.2	2.82
uni Flex ONE O	K1500	381.0	15.00	4.9	3.29
uni Flex ONE EW				4.9	3.29
uni Flex ONE EO/EOO				4.9	3.29
uni Flex ONE ER-/L/R*				5.0	3.36
uni Flex ONE ER/ER				5.1	3.43
uni Flex ONE O	K2400	609.6	24.00	7.9	5.31
uni Flex ONE EW				7.8	5.24
uni Flex ONE EO/EOO				7.8	5.24
uni Flex ONE ER-/L/R*				7.9	5.31
uni Flex ONE ER/ER				8.1	5.44

* L/R = L (left)/R (right). When ordering, please specify belt edge configuration on opposite side of edge roller (e.g. uni Flex ONE ER/EO = ER on left side and EO on right side - uni Flex ONE EW/ER = EW on left side and ER right side).

Surface Opening

Belt width	Opening at straight running belt	Opening min. flex ratio = 1.6
K750	13%	12%
K1200	13%	12%
K1500	15%	11%
K2400	17%	11%

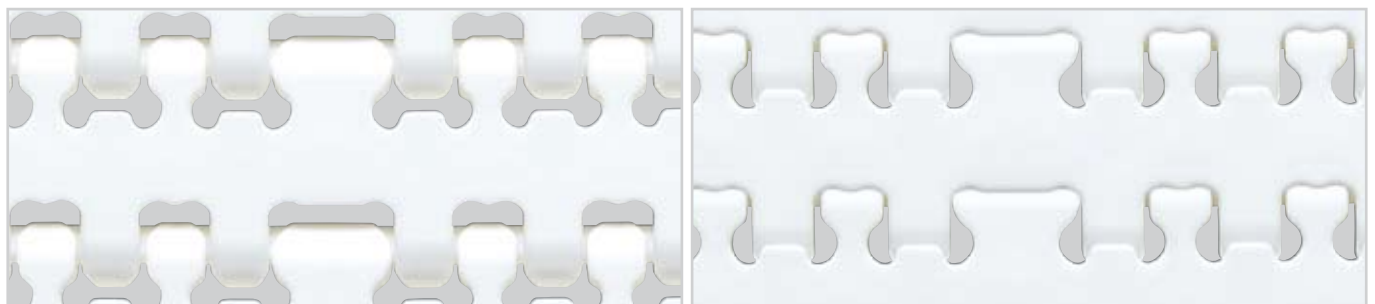
Compression

Compression rate is 23% (e.g. 1 meter (3.28 ft) of belt can compress 0.23 m (0.75 ft) to a length of 0.77 m (2.53 ft).

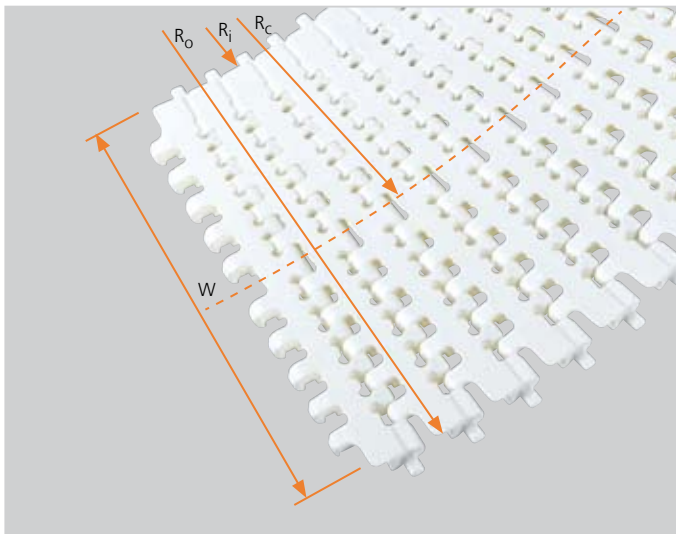
Technical Data

Assortment	POM			Min. Center Radius, R_c		Min. Inner Radius, R_i		Flex Ratio (R_i to W)
	Belt width W							
	Size	mm	in.	mm	in.	mm	in.	
uni Flex ONE O	K750	190.5	7.50	365.3	14.38	305.0	12.00	1.60
uni Flex ONE EW								
uni Flex ONE EO/EOO								
uni Flex ONE ER-/L/R*								
uni Flex ONE ER/ER								
uni Flex ONE O	K1200	304.8	12.00	612.4	24.11	488.0	19.21	1.60
uni Flex ONE EW								
uni Flex ONE EO/EOO								
uni Flex ONE ER-/L/R*								
uni Flex ONE ER/ER								
uni Flex ONE O	K1500	381.0	15.00	780.5	30.73	610.0	24.02	1.60
uni Flex ONE EW								
uni Flex ONE EO/EOO								
uni Flex ONE ER-/L/R*								
uni Flex ONE ER/ER								
uni Flex ONE O	K2400	609.6	24.00	1294.8	51.00	975.0	38.39	1.60
uni Flex ONE EW								
uni Flex ONE EO/EOO								
uni Flex ONE ER-/L/R*								
uni Flex ONE ER/ER								

On above belt width values, the belt width tolerance on standard materials is $+0/-0.4\%$ at $23^\circ\text{C}/73^\circ\text{F}$.

* L/R = L (left)/R (right). When ordering, please specify Belt Edge Configuration on opposite side of edge roller (e.g. uni Flex ONE ER/EO = ER on left side and EO on right side - uni Flex ONE EW/ER = EW on left side and ER right side).

Profiles for uni Flex ONE O/EO

Compact Profile Configuration

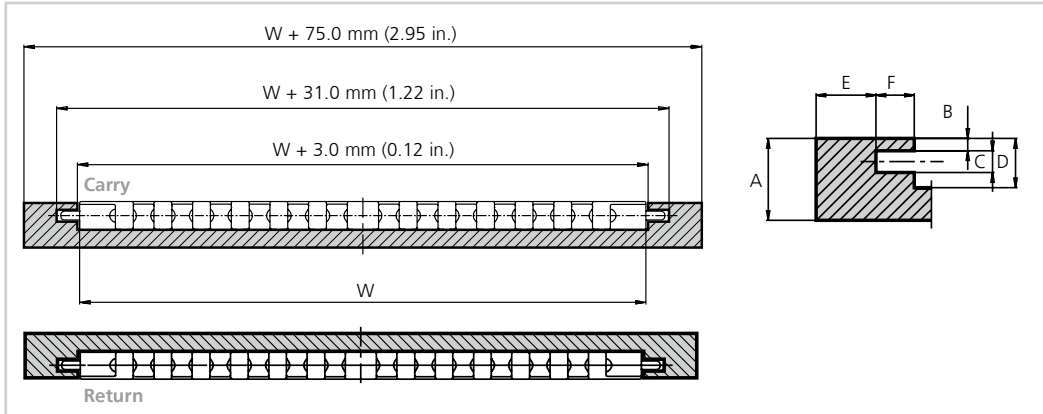

Dimensions

	mm	in.
A	30.0	1.18
B	4.5	0.18
C	8.0	0.31
D	18.0	0.71
E	22.0	0.87
F	14.0	0.55

Slotted Wearstrip Configuration

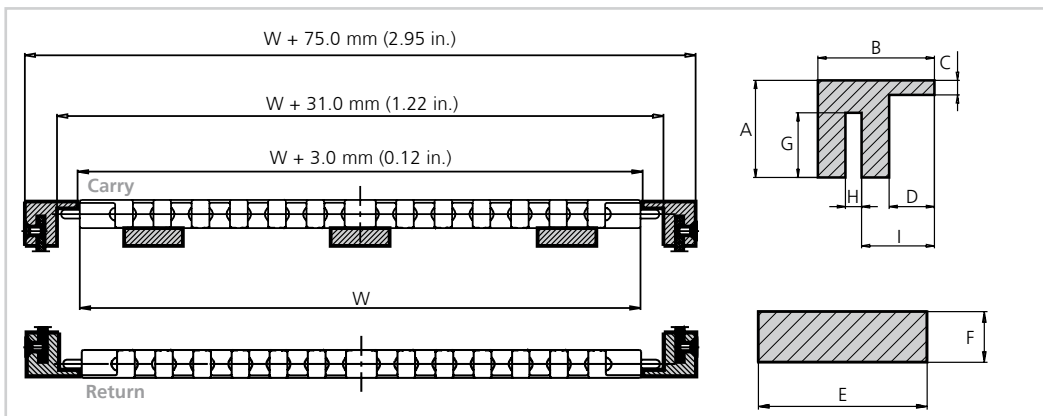

Dimensions

	mm	in.
A	30.0	1.18
B	36.0	1.42
C	4.5	0.18
D	14.0	0.55
E	40.0	1.57
F	12.0	0.47
G	20.0	0.79
H	5.0	0.20
I	22.5	0.89

Solid Wearstrip Configuration

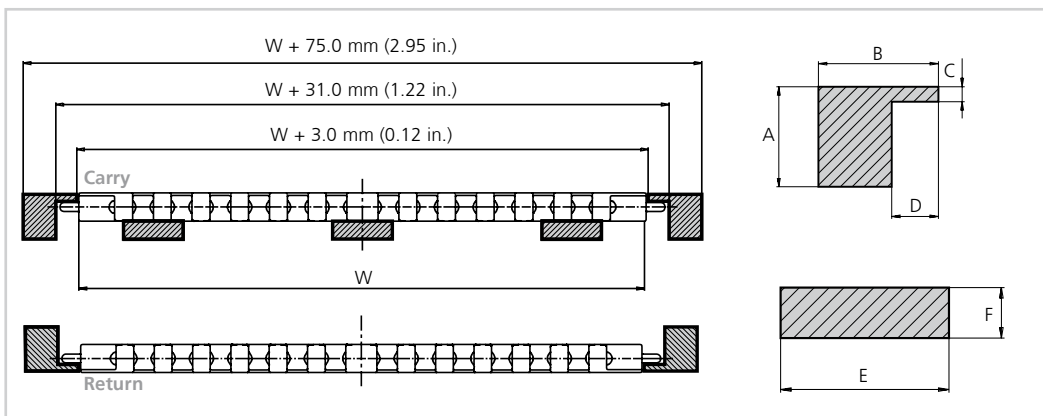

Dimensions

	mm	in.
A	30.0	1.18
B	36.0	1.42
C	4.5	0.18
D	14.0	0.55
E	40.0	1.57
F	12.0	0.47

Profiles for uni Flex ONE EW/ER

Compact Profile Configuration

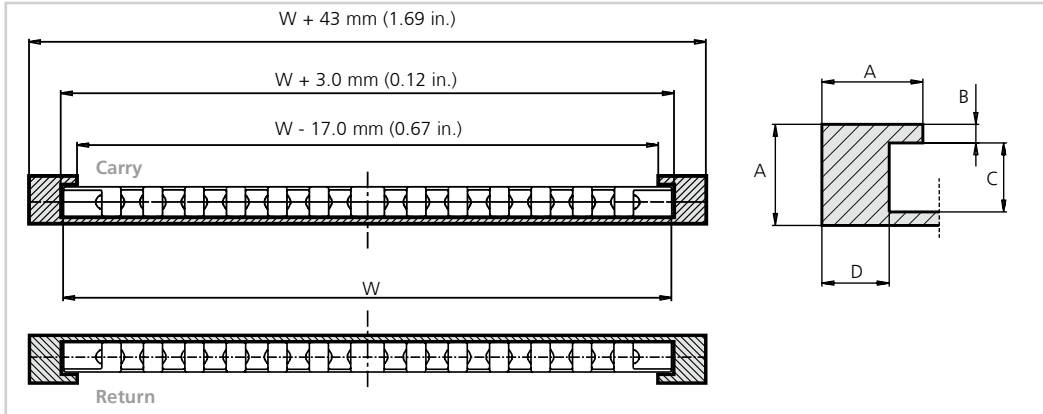

Dimensions

	mm	in.
A	30.0	1.18
B	5.5	0.22
C	20.5	0.81
D	20.0	0.79

Slotted Wearstrip Configuration

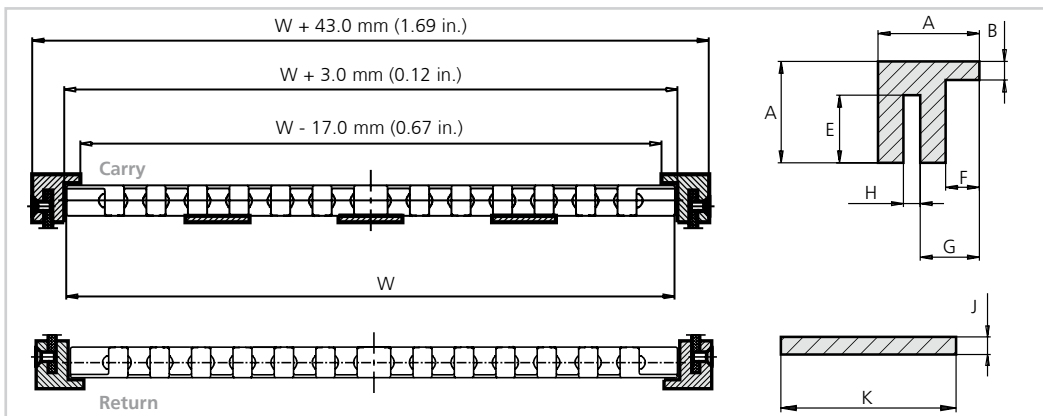

Dimensions

	mm	in.
A	30.0	1.18
B	5.5	0.22
E	20.0	0.79
F	10.0	0.39
G	17.5	0.69
H	5.0	0.20
J	4.0	0.16
K	40.0	1.57

Solid Wearstrip Configuration

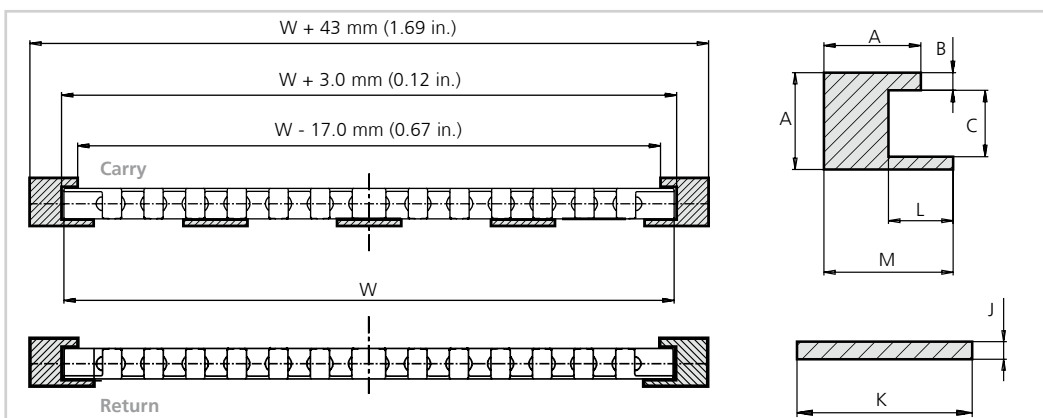

Dimensions

	mm	in.
A	30.0	1.18
B	5.5	0.22
C	20.5	0.81
J	4.0	0.16
K	40.0	1.57
L	20.0	0.79
M	40.0	1.57

Profiles for uni Flex ONE EOO

Compact Profile Configuration

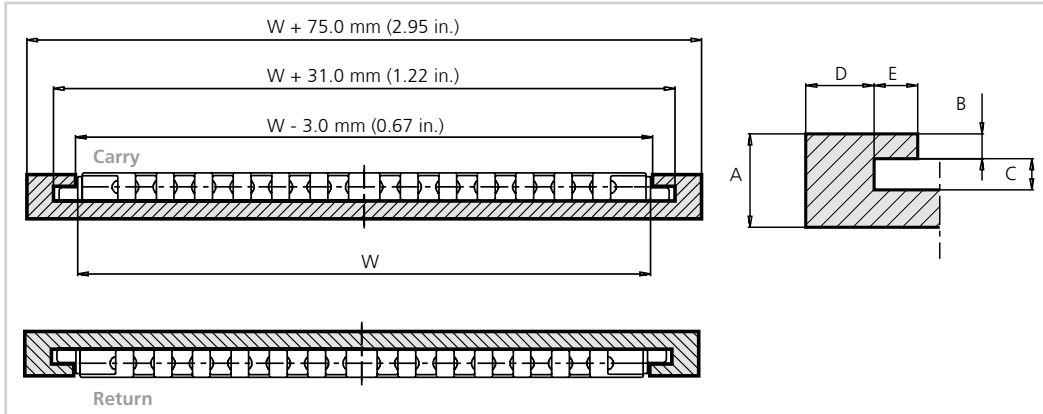

Dimensions

	mm	in.
A	30.0	1.18
B	8.0	0.31
C	10.0	0.39
D	22.0	0.87
E	14.0	0.55

Slotted Wearstrip Configuration

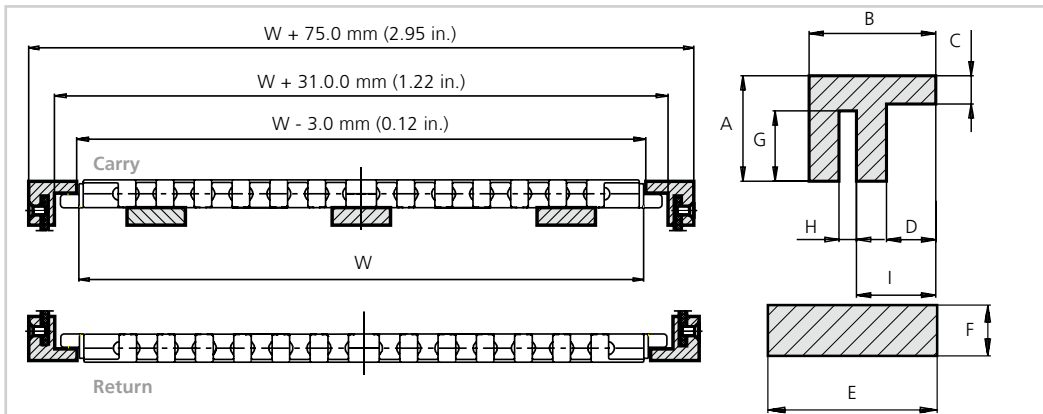

Dimensions

	mm	in.
A	30.0	1.18
B	36.0	1.42
C	8.0	0.79
D	14.0	0.55
E	40.0	1.57
F	12.0	0.47
G	20.0	0.79
H	5.0	0.20
I	22.5	0.89

Solid Wearstrip Configuration

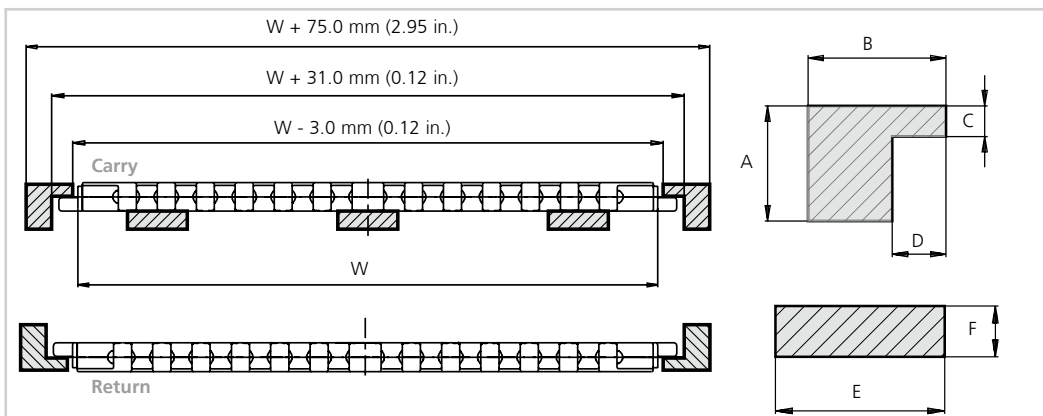

Dimensions

	mm	in.
A	30.0	1.18
B	36.0	1.42
C	8.0	0.31
D	14.0	0.55
E	40.0	1.57
F	12.0	0.47

Standard Sprockets

No. of teeth	Pitch diameter		Overall diameter		Hub diameter		Bore		Reference no. plastic
	mm	in.	mm	in.	mm	in.	mm	in.	
8	99.6	3.92	101.0	3.98	60.0	2.36	∅18.0/40.0*	∅0.71/1.57*	823PA6FONE08111LG00
					64.0	2.52	sq 25.4	sq 1.00	823PA6FONE08111LG00I100S
							sq 30.0	sq 1.18	823PA6FONE08111LG00M030S
9	111.4	4.39	113.7	4.48	70.0	2.76	∅18.0/40.0*	∅0.71/1.57*	823PA6FONE09111LG00
					74.0	2.91	sq 38.1	sq 1.50	823PA6FONE09111LG00I150S
							sq 40.0	sq 1.57	823PA6FONE09111LG00M040S
11	135.2	5.32	138.8	5.46	70.0	2.76	∅18.0/40.0*	∅0.71/1.57*	823PA6FONE11111LG00
					74.0	2.91	sq 38.1	sq 1.50	823PA6FONE11111LG00I150S
							sq 40.0	sq 1.57	823PA6FONE11111LG00M040S
					95.0	3.74	∅40.0/∅70.0	∅1.57/2.76	823PA6FONE11111LG01
					100	3.94	sq 50.8	sq 2.00	823PA6FONE11111LG00I200S
sq 60.0	sq 2.36	823PA6FONE11111LG00M060S							
12	147.2	5.80	151.2	5.95	70.0	2.76	∅18.0/40.0*	∅0.71/1.57*	823PA6FONE12111LG00
					74.0	2.91	sq 38.1	sq 1.50	823PA6FONE12111LG00I150S
							sq 40.0	sq 1.57	823PA6FONE12111LG00M040S
					110.0	4.33	∅40.0/∅70.0	∅1.57/2.76	823PA6FONE12111LG01
					114.0	4.49	sq 50.8	sq 2.00	823PA6FONE12111LG00I200S
sq 60.0	sq 2.36	823PA6FONE12111LG00M060S							
sq 63.5	sq 2.50	823PA6FONE12111LG00I250S							
13	159.2	6.27	163.6	6.44	70.0	2.76	∅18.0/40.0*	∅0.71/1.57*	823PA6FONE13111LGI00
					74.0	2.91	sq 38.1	sq 1.50	823PA6FONE13111LG00I150S
							sq 40.0	sq 1.57	823PA6FONE13111LG00M040S
					∅120.0	∅4.72	∅40.0/∅70.0	∅1.57/2.76	823PA6FONE13111LG01
					114.0	4.49	sq 50.8	sq 2.00	823PA6FONE13111LG00I200S
sq 60.0	sq 2.36	823PA6FONE13111LG00M060S							
sq 63.5	sq 2.50	823PA6FONE13111LG00I250S							
16	195.3	7.69	200.5	7.89	70.0	2.76	∅18.0/40.0*	∅0.71/1.57*	823PA6FONE16111LG00
					74.0	2.91	sq 38.1	sq 1.50	823PA6FONE16111LG00I150S
							sq 40.0	sq 1.57	823PA6FONE16111LG00M040S
					120.0	4.72	∅40.0/∅70.0	∅1.57/2.76	823PA6FONE16111LG01
					114.0	4.49	sq 50.8	sq 2.00	823PA6FONE16111LG00I200S
sq 60.0	sq 2.36	823PA6FONE16111LG00M060S							
sq 63.5	sq 2.50	823PA6FONE16111LG00I250S							

* Minimum/maximum round bore.

Placement of Wearstrips and Sprockets

No. of teeth	Minimum B-dimension		Wearstrip distance A	
	mm	in.	mm	in.
8	36.5	1.44	58.9	2.32
9	42.8	1.69	64.9	2.56
11	55.3	2.18	76.9	3.03
12	61.6	2.43	82.9	3.26
13	67.8	2.67	88.9	3.50
16	86.2	3.40	107.0	4.21

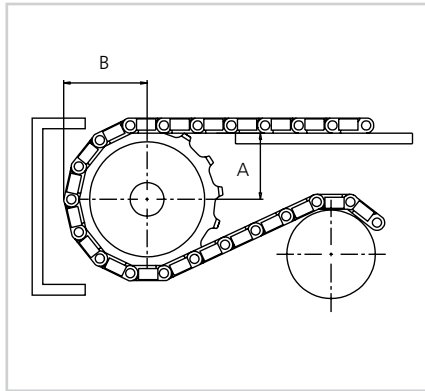

Placement and Number of Sprockets

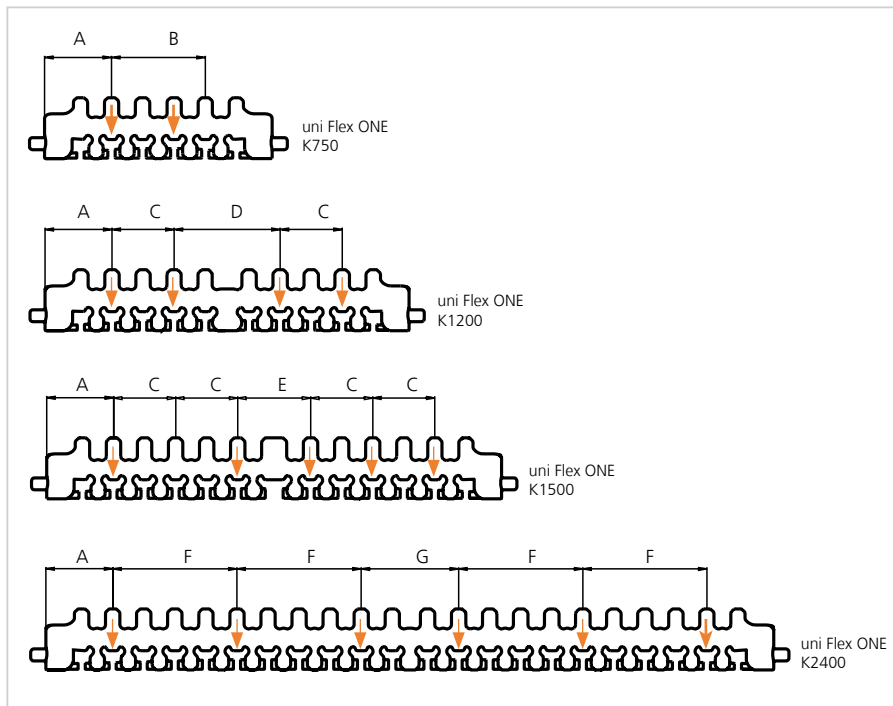

Dimensions

	mm	in.
A	56.0	2.20
B	78.5	3.10
C	52.0	2.05
D	88.8	3.50
E	61.0	2.40
F	104.0	4.10
G	81.6	3.21

Please note, if travel is in both directions, an extra set of sprockets is required.

Accessories | Idler

No. of teeth	Diameter idler	
	mm	in.
8	72.9	2.87
9	85.6	3.37
11	110.7	4.36
12	123.1	4.85
13	135.5	5.33
16	172.4	6.79

Recommended for use at idler end to ensure smooth and low noise operation.

uni Flex ONE Idler
Standard Material and Color
POM-D N
Accessories | Rubber Clip On

uni Flex ONE
 Rubber Clip On

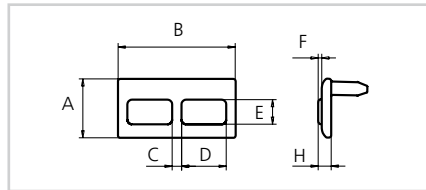
Dimensional Sketch

uni Flex ONE
 Rubber Clip On

Dimensions

	mm	in.
A	25.0	0.98
B	50.0	1.97
C	4.0	0.16
D	19.0	0.75
E	10.5	0.41
F	1.5	0.06

Accessories | Product Support

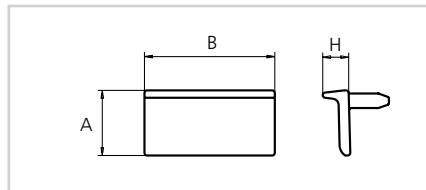
uni Flex ONE
 Product Support 10 mm

Dimensional Sketch

uni Flex ONE
 Product Support 10 mm

Standard Materials, Colors and Dimensions

Style	H		Standard materials & colors
	mm	in.	POM-D
uni Flex ONE Rubber Clip On	5.5	0.22	O + Rubber 03 K
uni Flex ONE Product Support	10.0	0.39	O

Pitch 50.8 mm (2.00 in.)



uni Flex L-ASB

This new generation of 2 in. pitch radius belts with or without hold down tabs offers a unique patent design providing an extremely strong radius belt.

Also a uni Flex L-ASB R with tighter turning radius is also available.

This new generation is easy to clean and combined with POM-D material, it has good release characteristics.

The increased lateral stability allows fewer support strips than normal.

The improved hygienic design of this straight and side flexing belt makes it the ideal processing belt in cooling, freezing, drying or proofing applications. The uni Flex L-ASB is a proven belt in spiral applications.

The uni Flex L-ASB Series increases performance in the following industries and applications:

- Bakery industry including pan handling, cooling lines, internal transport, packaging lines with demands for height belt strength
- Meat & poultry applications including packaging lines
- Spiral applications
- Furniture industry

Product features:

- Standard POM-D material containing a self-lubricating component, improving non-stick characteristics and reducing friction
- Easy to clean thanks to improved hygienic design of the hinges
- Tight radius application reducing space requirements
- Less support strips thanks to increased lateral stability
- Available with 2.2 and 1.6 collapsing factor

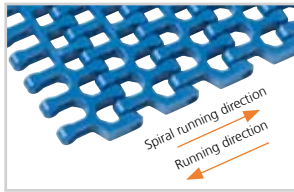
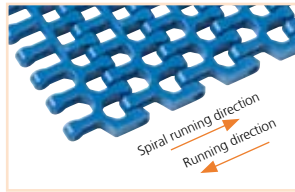
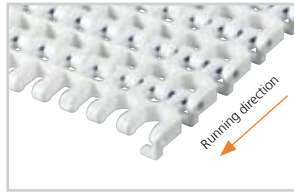
Standard Selection

uni Flex L-ASB
Surface opening 47%

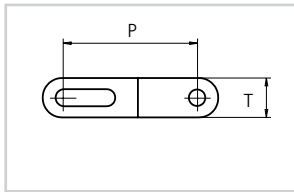
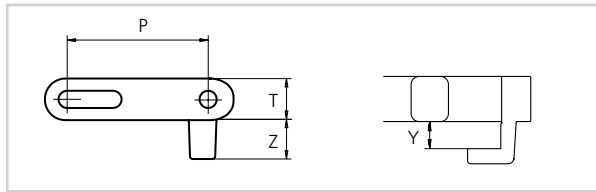
uni Flex L-ASB R
Surface opening 50%

uni Flex L-ASB T
Surface opening 47%

uni Flex ASB and uni Flex ASB T: Min. inside radius 2.2 x belt width.
uni Flex ASB-R: Min. inside radius 1.6 x belt width.

Dimensional Sketches

uni Flex L-ASB
uni Flex L-ASB R

uni Flex ASB T
Dimensions

	mm	in.
P	50.8	2.00
T	15.0	0.59
Y	9.0	0.35
Z	14.0	0.55

- Side flexing
- 50.8 mm (2.00 in.)
- Snap Pin A1
- $\varnothing 6.0$ mm (0.24 in.)
- Patent pending
- See page 11
- 100 mm (3.94 in.)
- See page 152
- See page 171
- Accessories**
- See page 151
- See page 151
- Alternatives**
- Snap Pin A1 **PP** **W**

Standard Materials and Colors

Type	Standard materials and colors	Standard pins materials and colors
uni Flex L-ASB	POM-D W	PA6.6 B
	POM-D B	PA6.6 B
	PP B	PA6.6 B
uni Flex L-ASB T	POM-D W	PA6.6 B
	POM-D B	PA6.6 B
	PP B	PA6.6 B
uni Flex L-ASB R	POM-D W	PA6.6 B
	POM-D B	PA6.6 B
	PP B	PA6.6 B

Standard Bricklaid Belt Widths

mm	in.	mm	in.	mm	in.	mm	in.	mm	in.	mm	in.	mm	in.	mm	in.
249	9.8	452	17.8	605	23.8	704	27.7	910	35.8	1087	42.8	1545	60.8	2002	78.8
325	12.8	478	18.8	630	24.8	783	30.8	935	36.8	1240	48.8	1697	66.8	2154	84.8
402	15.8	554	21.8	656	25.8	859	33.8	1011	39.8	1392	54.8	1849	72.8	2307	90.8

On above belt width values, the belt width tolerance on standard materials is +0/-0.4% at 23°C (73° F).

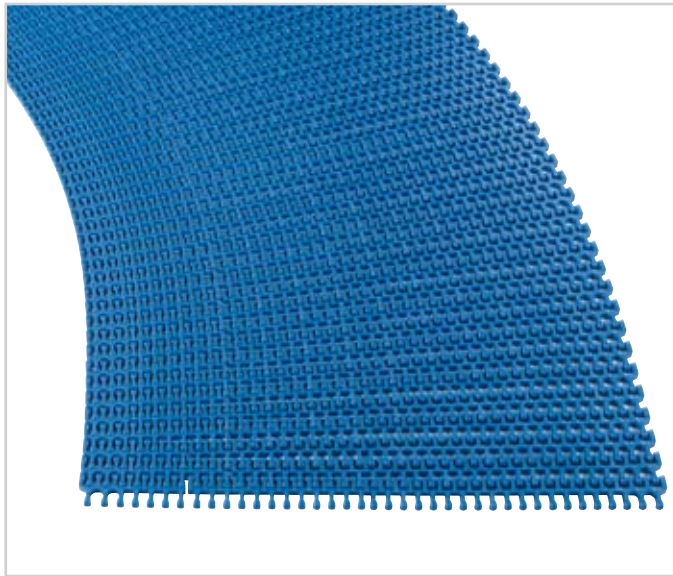
uni Flex L-ASB Single Link®

uni Flex L-ASB Single Link® is available in the following standard widths:

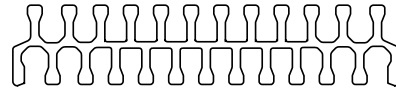
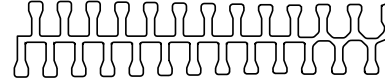
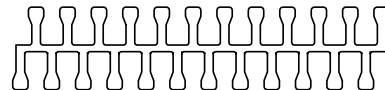
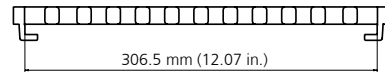
K1280 Both (325.9 mm (12.83 in.))

The both link is split in two and used as the outer part of the belt.
K1320 L-ASB R (331.5 mm (13.05 in.))

The R module is used as the inside part of the belt for a tighter radius.
K1200 Center (299.7 mm (11.80 in.))

The center module is used in the middle of the belt.
uni Flex L-ASB T

Standard Single Link®

Belt type and widths	K1200 Center 299.7 mm (11.80 in.)	K1280 Both 325.9 mm (12.83 in.)	K1320 331.5 mm (13.05 in.)
uni Flex L-ASB	X	X	
uni Flex L-ASB T		X	
uni Flex L-ASB R			X

Please note: Only the outer hinge from the both and the R modul can be used to retain the Snap Pin.

Max. Permissible Load in Curve

Belt material	Belt width W	POM		PP			
		PA6.6		PP		PA6.6	
Pin material	in.	N	lbf	N	lbf	N	lbf
uni Flex L-ASB T R	6 in. <= W < 12 in.	1830	411	1000	225	1060	238
	12 in. <= W < 18 in.	2440	559	1450	326	1440	346
	W > 18 in.	3110	699	1850	416	1960	441

Max. Permissible Load in Straight Sections

Belt material	POM		PP	
Pin material	PA6.6		PP PA6.6	
	N/m	lbf/ft	N/m	lbf/ft
uni Flex L-ASB T R	40000	2740	10250	1781

Belt Weights

Belt material	POM		PP	
Pin material	PA6.6		PP	
	kg/m ²	lb/ft ²	kg/m ²	lb/ft ²
uni Flex L-ASB T	9.8	2.00	6.0	1.20
uni Flex L-ASB R	9.8	2.00	-	-

Design Guidelines

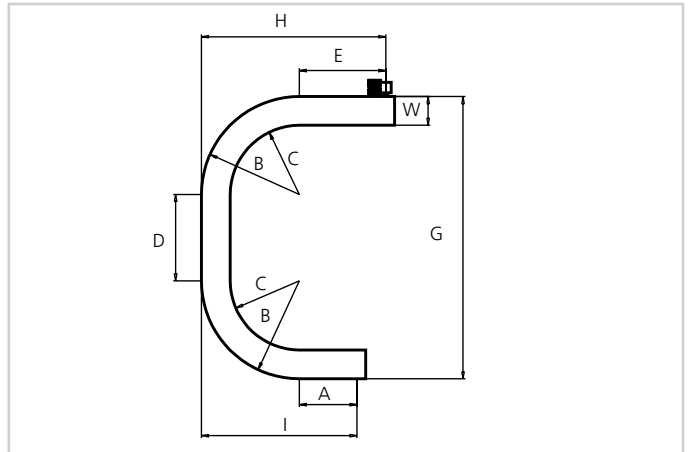
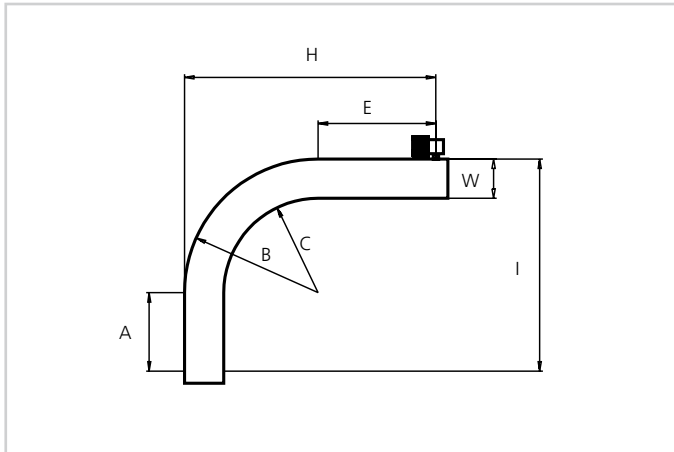

L - Conveyors

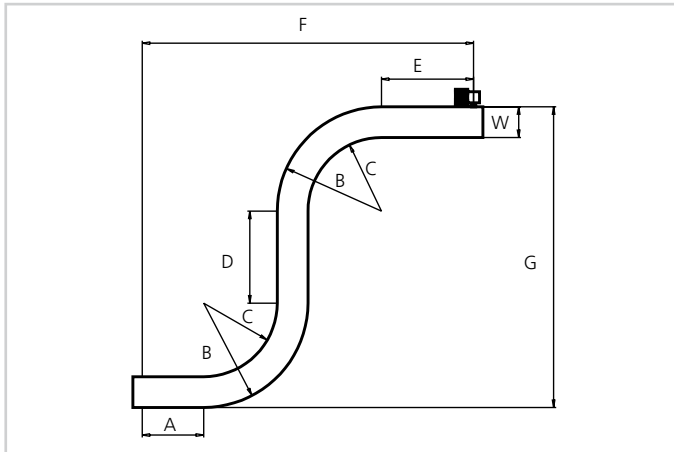

C - Conveyors

	uni Flex L-ASB uni Flex L-ASB T	uni Flex L-ASB R (inside)
A	min. 1.5 x W	min. 1.5 x W
B	min. 3.2 x W	min. 2.6 x W
C	min. 2.2 x W	min. 1.6 x W
D	min. 2.0 x W	min. 2.0 x W
E	min. 2.0 x W	min. 2.0 x W
F	min. 8.9 x W	min. 7.7 x W
G	min. 8.4 x W	min. 7.2 x W
H	min. 5.2 x W	min. 4.6 x W
I	min. 4.7 x W	min. 4.1 x W

S - Conveyors

uni Flex L-ASB R can not be used in S-conveyors.

Accessories | Lane Divider

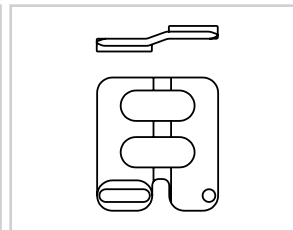
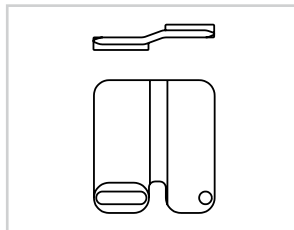
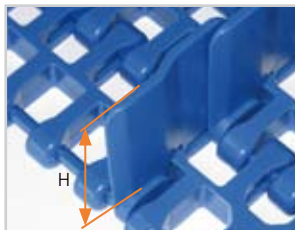

Lane Divider

Lane Divider

Lane Divider Airflow

Dimensions

Style	H	
	mm	in.
Lane Divider	10.0	0.39
Lane Divider	25.4	1.00
Lane Divider	50.0	2.00
Lane Divider Airflow	50.0	2.00

Standard Material and Color

POM-D **B**

Accessories | Radius Lock



Standard Materials and Colors

Flex ratio 2.5 POM-D **O** Flex ratio 2.8 POM-D **B**

Radius Lock

Standard Sprockets

No. of teeth	Pitch diameter		Overall diameter		Hub diameter		Bore		Reference no. plastic
	mm	in.	mm	in.	mm	in.	mm	in.	
8	131.5	5.18	134.6	5.30	0	0	∅18.0/70.0	∅0.71/2.76	673PA6FLASB08211N00
					0	0	sq 38.1	sq 1.50	673PA6FLASB08211N00I150S
					0	0	sq 40.0	sq 1.57	673PA6FLASB08211N00M040S
					0	0	sq 50.8	sq 2.00	673PA6FLASB08211N00I200S
10	164.0	6.46	168.3	6.63	0	0	∅18.0/70.0	∅0.71/2.76	673PA6FLASB10211N00
					0	0	sq 38.1	sq 1.50	673PA6FLASB10211N00I150S
					0	0	sq 40.0	sq 1.57	673PA6FLASB10211N00M040S
					0	0	sq 50.8	sq 2.00	673PA6FLASB10211N00I200S
12	196.5	7.74	203.5	8.01	0	0	∅18.0/120.0	∅0.71/4.76	673PA6FLASB12211N00
					0	0	sq 38.1	sq 1.50	673PA6FLASB12211N00I150S
					0	0	sq 40.0	sq 1.57	673PA6FLASB12211N00M040S
					0	0	sq 50.8	sq 2.00	673PA6FLASB12211N00I200S
15	245.4	9.66	253.4	9.98	0	0	∅18.0/150.0	∅0.71/5.91	673PA6FLASB15211N00
					0	0	sq 38.1	sq 1.50	673PA6FLASB15211N00I150S
					0	0	sq 40.0	sq 1.57	673PA6FLASB15211N00M040S
					0	0	sq 50.8	sq 2.00	673PA6FLASB15211N00I200S
					0	0	sq 60.0	sq 2.36	673PA6FLASB15211N00M060S
					0	0	sq 63.5	sq 2.50	673PA6FLASB15211N00I250S

Placement of Wearstrips and Sprockets

No. of teeth	Minimum B-dimension		Wearstrip distance A	
	mm	in.	mm	in.
8	74.4	2.93	54.3	2.14
10	90.3	3.56	71.3	2.81
12	106.4	4.19	88.0	3.47
15	130.6	5.14	112.9	4.45

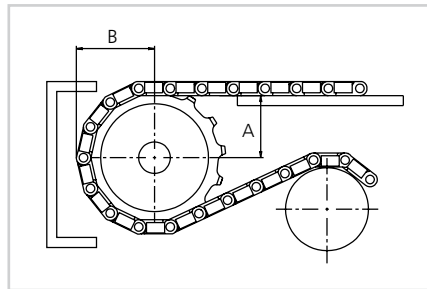
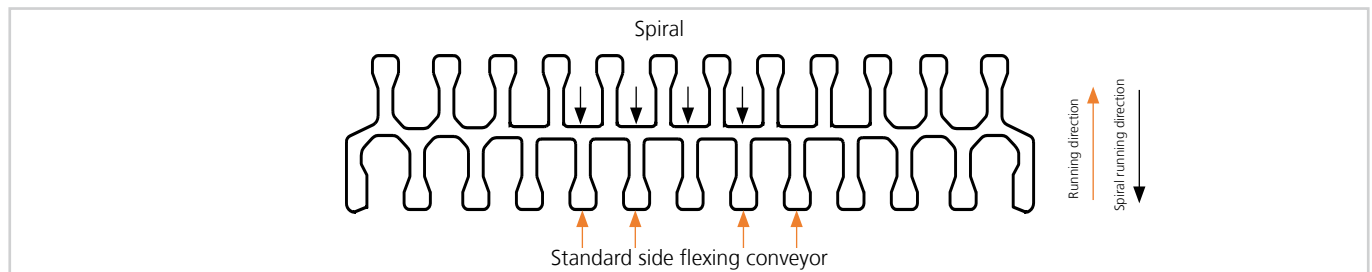
Placing of Sprockets

Max. Load per Sprocket

Belt material	POM		PP	
	N	lbf	N	lbf
uni Flex L-ASB	2500	562	1200	270

Made-To-Order Selection



uni M-SNB M2
Surface opening 14%

Dimensional Sketch

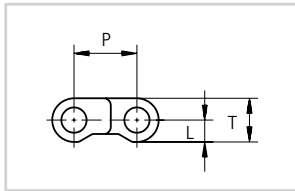

uni M-SNB M2

Dimensions

	mm	in.
L	4.4	0.17
P	12.7	0.50
T	8.8	0.35

- Straight running
- 12.7 mm (0.50 in.)
- \varnothing 5 mm (0.20 in.)
- Patented
- See page 11
- 20 mm (0.8 in.)
- See page 35
- See page 171
- 01 N See page 16
- PP B W
- PP B PA6.6 B N SS304
PE W
- PP W PA6.6 D
- PA6.6 N

Made-To-Order Materials

POM-D, PP and PE

Standard Bricklaid Belt Widths

mm	in.	mm	in.	mm	in.	mm	in.	mm	in.
76	3.0	685	27.0	1294	50.9	1902	74.9	2510	98.8
152	6.0	762	30.0	1370	53.9	1978	77.9	2586	101.8
228	9.0	837	33.0	1446	56.9	2054	80.9	2662	104.8
304	12.0	914	36.0	1522	59.9	2130	83.9	2738	107.8
381	15.0	990	39.0	1598	62.9	2206	86.9	2814	110.8
456	18.0	1066	42.0	1674	65.9	2282	89.8	2890	113.8
533	21.0	1142	45.0	1750	68.9	2358	92.8	2966	116.8
608	23.9	1218	48.0	1826	71.9	2434	95.8	3042	119.8

On above belt width values, the belt width tolerance on standard materials is +0/-0.4% at 23°C (73° F).

Made-To-Order Selection



uni Light CR



uni Light 10% SR



uni Light 18%

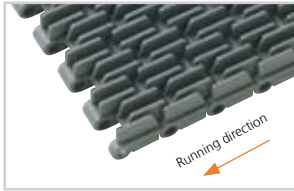

uni Light Rib

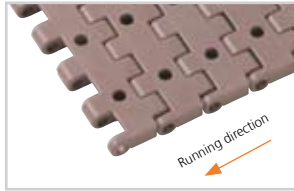

uni Light Vacuum



uni Light Flat Rubber Top



uni Light Rough Rubber Top

Note: uni Light Flat Rubber Top and uni Light Rough Rubber Top are only available in PP.

Dimensional Sketches

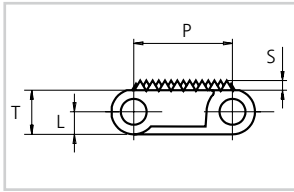

uni Light CR

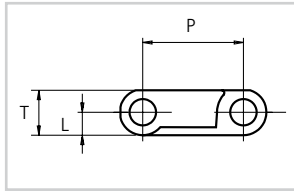

uni Light 10% SR

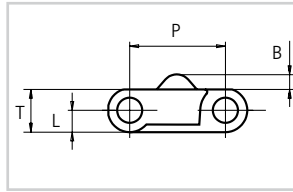

uni Light 18%

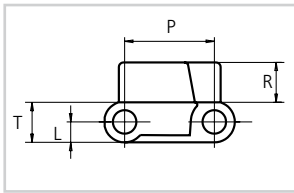

uni Light Rib

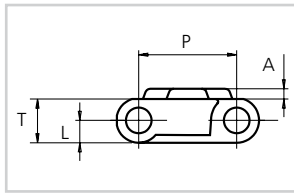

uni Light Vacuum

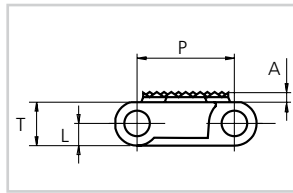

uni Light Flat Rubber Top

Dimensions for uni Light Vacuum

mm	in.	No. of holes	Total open area %
3.2	0.13	5	7.64
4.0	0.16	5	8.40
4.0	0.16	7	9.24
4.0	0.16	8	9.66
5.2	0.20	5	9.87
5.6	0.22	7	12.10
5.6	0.22	8	12.93



Straight running both directions



19.05 mm (0.75 in.)



ø5 mm (0.20 in.)



Patented



See page 11



25 mm (1.0 in.)
uni Light Rib: 50 mm (2.0 in.)



See page 39



See page 171



PP **W** **G** **B**



03 **K** See page 16



PP **W** **PA6.6** **N** **B** **SS304**
PE **W** **GR** **N**



PA6.6 **N** **D**



PP **W**

Accessories



See page 40



See page 41



See page 40



See page 156

Dimensions

	mm	in.
A	2.0	0.08
B	3.0	0.12
L	4.3	0.17
P	19.1	0.75
R	7.3	0.29
S	1.5	0.06
T	8.5	0.33

Made-To-Order Materials

POM-D, POM-LF, PP, PE and PA6

Made-To-Order Bricklaid Belt Widths

mm	in.	mm	in.	mm	in.	mm	in.
76	3.0	840	33.1	1604	63.1	2369	93.3
153	6.0	917	36.1	1681	66.2	2445	96.3
229	9.0	993	39.1	1757	69.2	2522	99.3
306	12.0	1070	42.1	1834	72.2	2598	102.3
382	15.0	1146	45.1	1910	75.2	2674	105.3
458	18.0	1223	48.1	1987	78.2	2751	108.3
535	21.1	1299	51.1	2063	81.2	2827	111.3
611	24.1	1375	54.1	2139	84.2	2904	114.3
687	27.0	1451	57.1	2216	87.2	2980	117.3
764	30.1	1528	60.2	2292	90.2	3057	120.4

On above belt width values, the belt width tolerance on standard materials is +0/-0.4% at 23°C/73°F.

Belt Weights

Belt material	POM				PP				PE			
	plastic		steel		plastic		steel		plastic		steel	
	kg/m ²	lb/ft ²	kg/m ²	lb/ft ²	kg/m ²	lb/ft ²	kg/m ²	lb/ft ²	kg/m ²	lb/ft ²	kg/m ²	lb/ft ²
uni Light C	6.8	1.39	14.2	2.91	4.8	0.98	12.2	2.50	4.9	1.00	12.4	2.54
uni Light 10%	6.2	1.27	13.7	2.81	4.3	0.88	11.9	2.44	4.6	0.94	12.1	2.48
uni Light 18%	5.5	1.13	13.0	2.66	3.9	0.80	11.5	2.36	4.1	0.84	11.6	2.38
uni Light Rib	9.2	1.88	16.8	3.44	6.3	1.29	13.9	2.85	6.6	1.35	14.1	2.89
uni Light Vacuum	6.5	1.33	14.0	2.87	4.4	0.90	12.0	2.46	4.7	0.96	12.2	2.50
uni Light Flat Rubber Top	-	-	-	-	5.5	1.13	13.0	2.66	-	-	-	-

Permissible Tensile Strength

Belt material	POM		PP		PE	
	N/m	lbf/ft	N/m	lbf/ft	N/m	lbf/ft
uni Light	10250	702	5125	351	3075	211
uni Light Rough Rub. Top	-	-	5125	351	-	-

Made-To-Order Accessories | Finger Plates

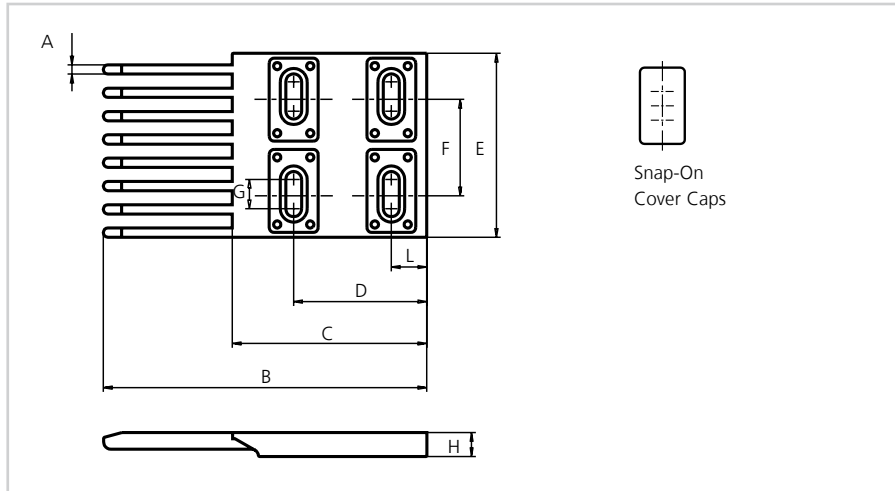

uni Light Finger Plate Type 1A K300

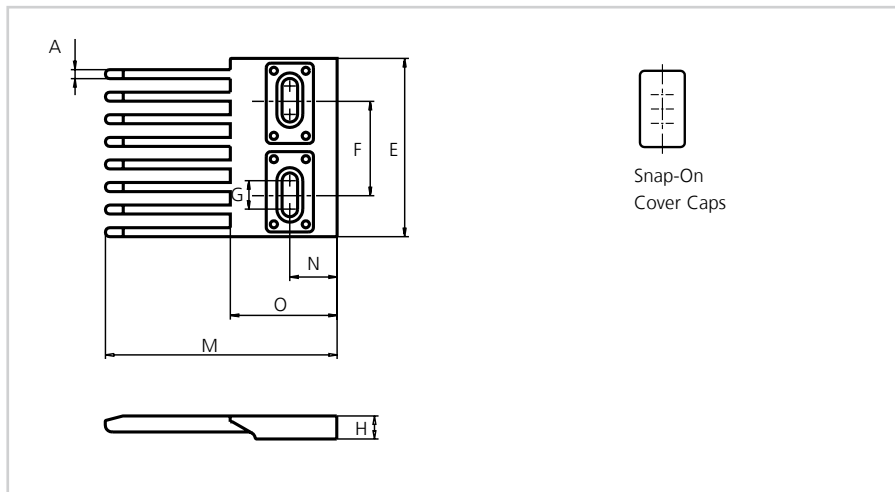

uni Light Finger Plate Type 2 K300

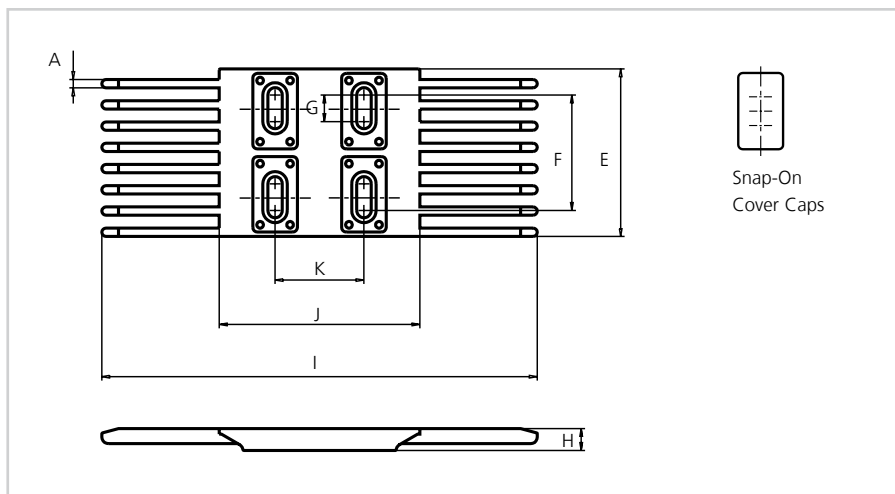

uni Light Finger Plate Type 2 K300

Made-To-Order Materials

POM-LF, POM-DI and POM-EC

Dimensions

	mm	in.
A	3.8	0.15
B	132.9	5.23
C	80.0	3.15
D	14.9	0.59
E	75.4	2.97
F	40.0	1.57
G	12.0	0.47
H	10.0	0.39
I	197.1	7.76
J	90.3	3.56
K	40.0	1.57
L	54.5	2.15
M	98.9	3.89
N	20.0	0.79
O	45.2	1.78

All uni-chains belt systems that are available in a raised rib version can be supplied with matching finger plates, also called combs. The finger plates are supplied with cover caps which can be attached when the finger plate has been installed. The cover caps can be removed by using a screwdriver that can be inserted between the cover and finger plates. In order to adjust to belt width variations caused by temperature fluctuations, a slider facilitates the sideways movement of the finger plates (finger plate type 2).

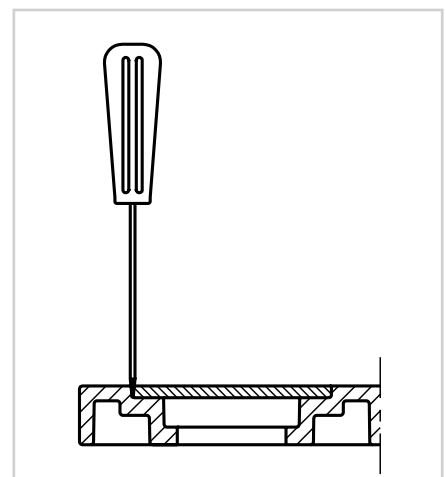

Made-To-Order Selection

uni SNB M2 with Rollers

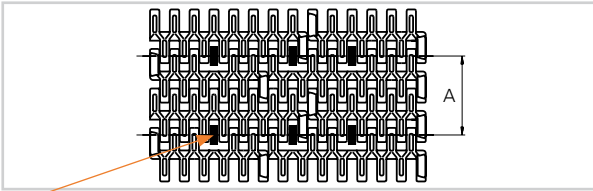
Dimensional Sketch

Roller

ø12 x 5.5 mm (ø0.5 x 0.2 in.)

Dimensions

	mm	in.
A min.	50.8	2.00

Made-To-Order Material

POM-D, PP, PA6.6 and Roller Material POM-D

- Side flexing
- 25.4 mm (1.00 in.)
- ø5 mm (0.20 in.)
- See page 11
- 30 mm (1.2 in.)
- See page 63
- See page 171
- PP **B** **W** **G**
- PP **W** PA6.6 **B** **SS304**
- PE **W**
- PA6.6 **N** **D**

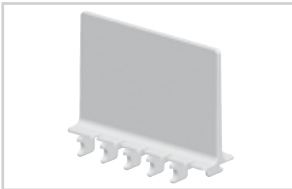
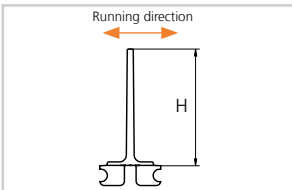
Made-To-Order Accessories | Product Support

Product Support
Dimensional Sketch

Product Support
Dimensions

H		Width		
mm	in.	Type	in.	in.
25.4	1.00	K300	75.9	2.99
50.8	2.00	K300	75.9	2.99
76.2	3.00	K300	75.9	2.99

Made-To-Order Material

POM-D, PP, PA6.6 and PE

Accessories

- See page 61

* Only for uni SNB M2 34% and uni SNB M2 34% Rib. Not 20%-style belts.

Made-To-Order Selection



uni Light EP C



uni Light EP Rib C



uni Light EP 8.5%



uni Light EP 18%



uni Light EP 22%



uni Light EP 28%



uni Light EP 33%

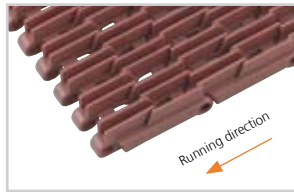

uni Light EP 33% Rib



uni Light EP 46%



uni Light EP Vacuum

Dimensional Sketches

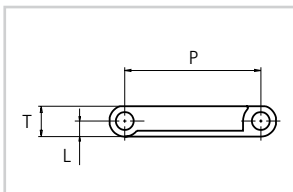

uni Light EP

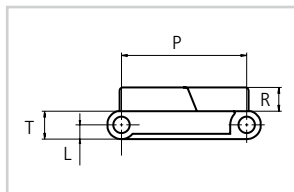

uni Light EP Rib C
uni Light EP Rib 33%

Dimensions

	mm	in.
L	4.3	0.17
P	38.1	1.50
R	7.3	0.29
T	8.5	0.33

Made-To-Order Materials

POM-D, POM-LF and PE

- Straight running
- 38.1 mm (1.50 in.)
- \varnothing 5 mm (0.20 in.)
- Patented
- See page 11
- 75 mm (3.0 in.)
uni Light EP Rib: 150 mm (5.9 in.)
- See page 77
- See page 171
- PP **B** **W** **G**
- PP **W** PA6.6 **B** SS304
PE **W**
- PP **W**

Accessories

- See page 160
- See page 161
- See page 160
- See page 162
- See page 76

Made-To-Order Bricklaid Belt Widths

mm	in.	mm	in.	mm	in.	mm	in.	mm	in.
102	4.0	661	26.0	1170	46.1	1678	66.1	2186	86.1
152	6.0	712	28.0	1220	48.0	1728	68.0	2236	88.0
254	10.0	763	30.0	1271	50.0	1779	70.0	2287	90.0
305	12.0	814	32.0	1322	52.0	1830	72.0	2338	92.0
355	14.0	865	34.1	1373	54.1	1881	74.1	2389	94.1
406	16.0	916	36.1	1424	56.1	1932	76.1	2440	96.1
458	18.0	966	38.0	1474	58.0	1982	78.0	-	-
509	20.0	1017	40.0	1525	60.0	2033	80.0	-	-
559	22.0	1068	42.0	1576	62.0	2084	82.0	-	-
610	24.0	1119	44.1	1627	64.1	2135	84.1	-	-

On above belt width values, the belt width tolerance on standard materials is +0/-0.4% at 23°C (73° F).

Belt Weights

Belt material	POM				PP				PE			
	plastic		steel		plastic		steel		plastic		steel	
	kg/m ²	lb/ft ²	kg/m ²	lb/ft ²	kg/m ²	lb/ft ²	kg/m ²	lb/ft ²	kg/m ²	lb/ft ²	kg/m ²	lb/ft ²
uni Light EP C 8.5% vac.	5.7	1.17	9.3	1.90	3.7	0.76	7.3	1.50	4.0	0.82	7.6	1.56
uni Light EP 18% 28%	4.8	0.98	8.4	1.72	3.4	0.70	7.0	1.43	3.6	0.74	7.2	1.47
uni Light EP 33% 46%	4.4	0.90	8.0	1.64	3.1	0.63	6.7	1.37	3.3	0.68	6.9	1.41
uni Light EP Rib	7.1	1.45	10.7	2.19	4.6	0.94	8.2	1.68	5.0	1.02	8.6	1.76

Permissible Tensile Strength

Belt material	POM		PP		PE	
	N/m	lbf/ft	N/m	lbf/ft	N/m	lbf/ft
uni Light EP	10250	702	5125	351	3075	211

Made-To-Order Accessories | Tab

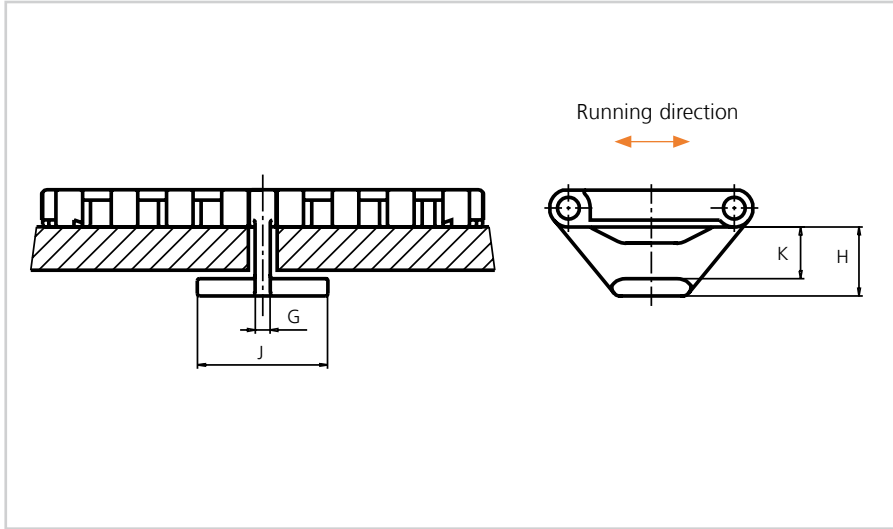

Dimensions

	mm	in.
G	3.5	0.14
H	16.4	0.65
J	26.0	1.02
K	12.4	0.49

Note: When using tabs please verify that sufficient clearance to the shaft exists. Max. shaft diameter = Sprocket pitch diameter - 44.5 mm (1.75 in.). When using square shafts verify that the diagonal does not exceed above max. diameter.
Example: Sprocket z = 7: Max. shaft diameter $87.8 - 44.5 = \varnothing 43$ mm ($3.46 - 1.75 = \varnothing 1.7$ in.).

uni Light EP Tab

Made-To-Order Material

POM-D

Note: In belt systems with tabs, the temperature of the conveyor should be constant. Please note that the tabs are not always placed in the middle of the belt.

Made-To-Order Accessories | Side Guard

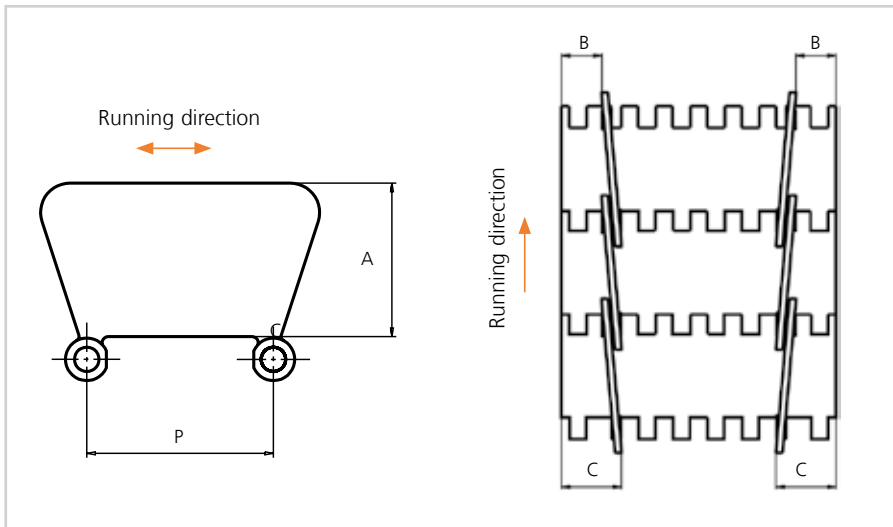

Dimensions

	mm	in.
A	31.7	1.25
B	15.0	0.59
C	23.0	0.91
P	38.1	1.50

Increment: 6.5 mm (0.26 in.).

uni Light Side Guard

Made-To-Order Material

POM-D

Made-To-Order Accessories | Product Support

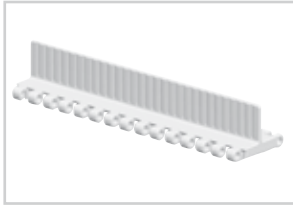

uni Light EP
Product Support flat (no ribs)

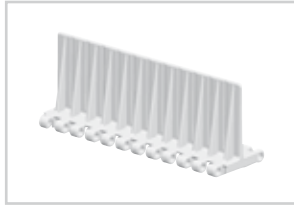

uni Light EP
Product Support with Ribs

Dimensional Sketches

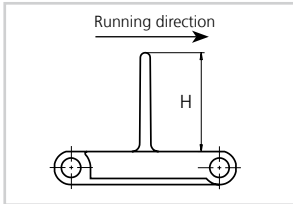

uni Light EP
Product Support flat (no ribs)

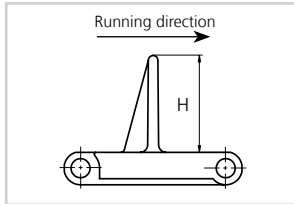

uni Light EP
Product Support with Ribs

Made-To-Order Materials

POM-D, PP-I and PE

Dimensions

Style	H		Width			Indent left/right	
	mm	in.	Type	mm	in.	mm	in.
uni Light EP Product Support flat	25.4	1.00	K750	191.0	7.52	no*	
uni Light EP Product Support with Ribs			K400	101.6	4.00	no*	
			K600	152.8	6.02	no*	
uni Light EP Product Support with Ribs	50.8	2.00	K400	101.6	4.00	no*	
			K600	152.8	6.02	no*	
uni Light EP Product Support flat	76.2	3.00	K750	191.0	7.52	17.5	0.69
uni Light EP Product Support with Ribs			K600	152.8	6.02	no*	

* Minimum bricklaid indent for uni Light EP product support is 38.1 mm (1.50 in.). Increment: 12.7 mm (0.50 in.).

Made-To-Order Selection Accessories

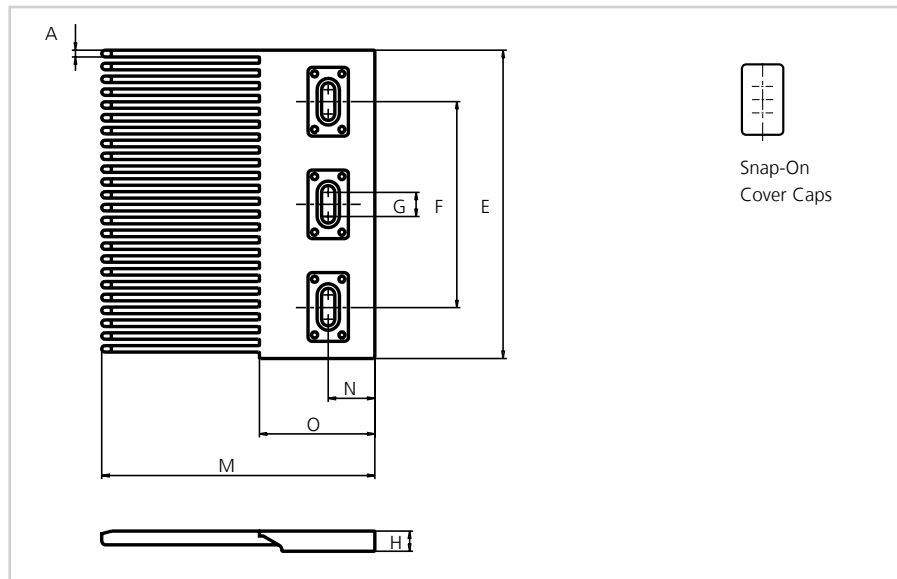

Dimensions

	mm	in.
A	3.3	0.13
E	152.4	6.00
F	101.6	4.00
G	12.0	0.47
H	10.3	0.41
M	135.0	5.31
N	23.0	0.91
O	57.0	2.24

uni Light EP Finger Plate Type 2

All belt systems from uni-chains are available in a raised rib version and can be supplied with matching finger plates, also called combs. The finger plates are supplied with cover caps which can be attached when

the finger plate has been installed. The cover caps can be removed by using a screwdriver that can be inserted between the cover and finger plates.

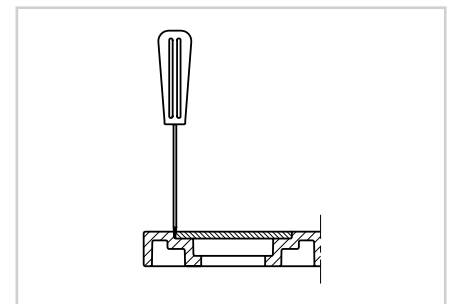

Made-To-Order Selection



uni SSB Rubber Top

Dimensional Sketch

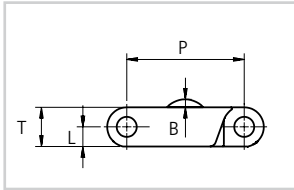

uni SSB Rubber Top

Dimensions

	mm	in.
B	2.5	0.10
L	6.4	0.25
P	38.1	1.50
T	12.7	0.50

- Straight running
- 38.1 mm (1.50 in.)
- ø6.35 mm (0.25 in.)
- Materials** See page 11
- 45 mm (1.8 in.)
- See page 72
- See page 72
- See page 171
- PP** **B**
- GR** **N** **SS304**
- 05** **I** See page 16

Made-To-Order Materials

POM-SLF, POM-LF and GR

Made-to-Order Bricklaid Belt Widths

mm	in.	mm	in.	mm	in.	mm	in.	mm	in.
76	3.0	683	26.9	1291	50.8	1899	74.8	2507	98.7
152	6.0	759	29.9	1367	53.8	1975	77.8	2583	101.7
228	9.0	835	32.9	1443	56.8	2051	80.7	2659	104.7
304	12.0	911	35.9	1519	59.8	2127	83.7	2735	107.7
380	15.0	987	38.9	1595	62.8	2203	86.7	2811	110.7
456	18.0	1063	41.9	1671	65.8	2279	89.7	2887	113.7
532	20.9	1139	44.8	1747	68.8	2355	92.7	2963	116.7
607	23.9	1216	47.9	1823	71.8	2431	95.7	3039	119.6

On above belt width values, the belt width tolerance on standard materials is +0/-0.4% at 23°C (73° F).

Belt Weights

Belt material	POM					
	GR		PP		steel	
	kg/m ²	lb/ft ²	kg/m ²	lb/ft ²	kg/m ²	lb/ft ²
uni SSB Rubber Top	12.4	2.54	12.2	2.50	15.0	3.07

Made-To-Order Selection



uni OPB C

uni OPB Rough

uni OPB 20%



uni OPB 25%

uni OPB vacuum
Surface opening 6%

uni OPB Rubber Top
Type RB1



uni OPB Rubber Top
Type RB2

uni OPB Rubber Top
Type RB3

*Ammeraal Beltech Modular recommends this travel direction. However, travel in both directions is possible.

Made-To-Order Materials

POM-D, POM-LF, POM-SLF, PP, PE, PA6.6 and PA6.6H

- Straight running
- 50.0 mm (1.97 in.)
- \varnothing 8 mm (0.31 in.)
- See page 11
- Rib: 300 mm (11.8 in.)
Side Guards: 200 mm (7.9 in.)
- See page 87
- See page 171
- PP **W** PE **W** PA6.6 **N**
- PP **W** **G** **B** PE **W** **B**
- PP **W** PE **W** **SS304** **SS316**
- PP **W**
- 03** **N** **K** See page 16

Accessories

- See page 166
- See page 167
- See page 89

Made-to-Order Bricklaid Belt Widths

mm	in.	mm	in.	mm	in.	mm	in.	mm	in.
151	5.9	452	17.8	754	29.7	1055	41.5	2262	89.1
185	7.3	486	19.1	788	31.0	1206	47.5	2413	95.0
268	10.6	503	19.8	804	31.7	1357	53.4	2564	100.9
302	11.9	536	21.1	872	34.3	1508	59.4	2714	106.9
335	13.2	570	22.4	905	35.6	1659	65.3	2865	112.8
386	15.2	603	23.7	938	36.9	1810	71.2	3016	118.7
403	15.9	636	25.0	988	38.9	1960	77.2	3167	124.7
418	16.5	703	27.7	1022	40.2	2111	83.1	3318	130.6

On above belt width values, the belt width tolerance on standard materials is +0/-0.4% at 23°C (73° F).

Dimensional Sketches

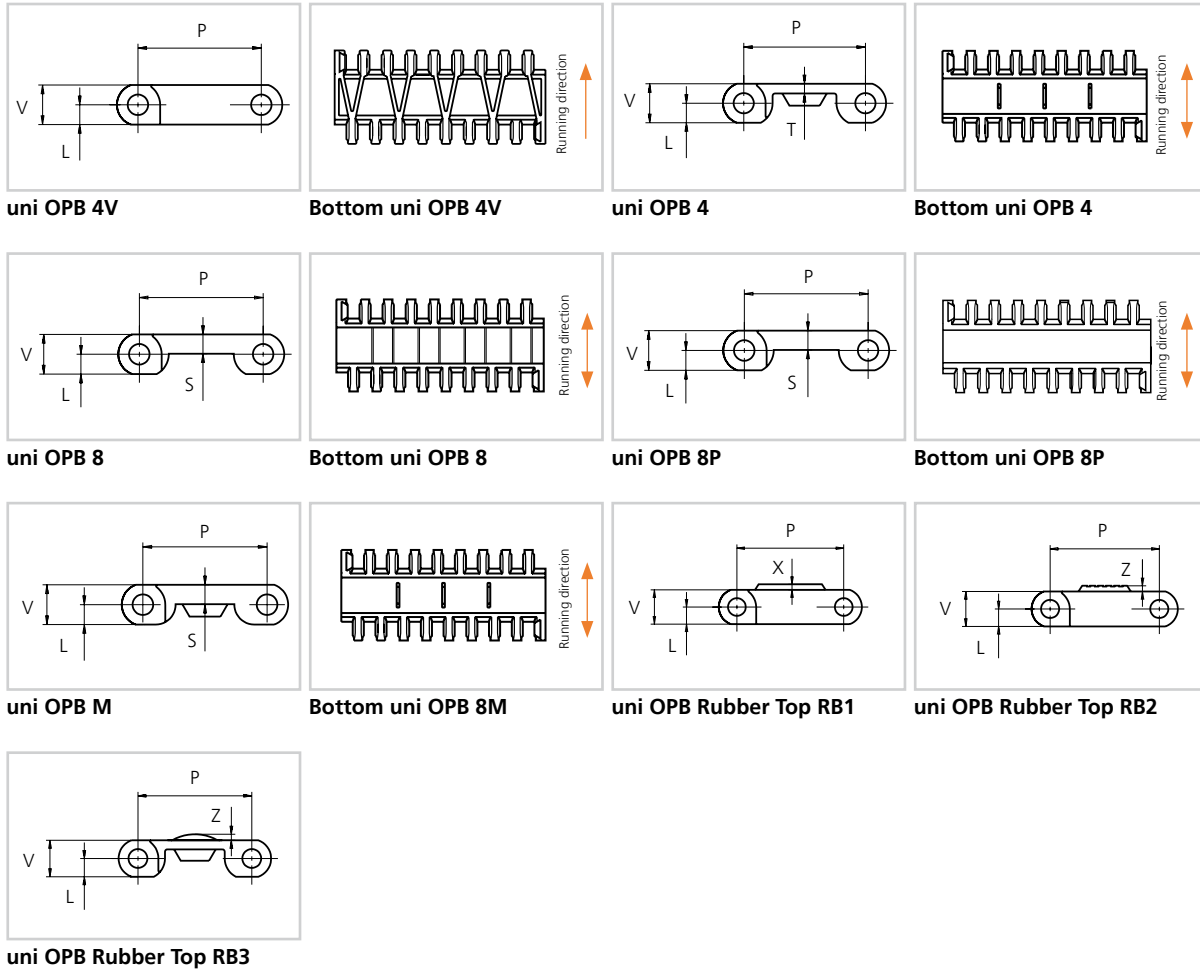

Dimensions

	mm	in.
L	8.0	0.31
P	50.0	1.97
S	7.8	0.31
T	4.0	0.16
V	16.0	0.63
X	2.5	0.10
Z	2.0	0.08

Combinations of Top and Bottom Surfaces

Bottom	uni OPB 4	uni OPB 8M	uni OPB 4V	uni OPB 8	uni OPB 8P
Top					
uni OPB C	X*	X	X*	X*	X
uni OPB C Rough			X	X	
uni OPB 20%				X	
uni OPB 25%				X*	
uni OPB Vacuum	X		X		

* Note: These types are listed in the USDA "Accepted Meat and Poultry Equipment" publication as accepted for food contact.

Belt Weights

Belt material	POM				PP				PE			
	plastic		steel		plastic		steel		plastic		steel	
	kg/m ²	lb/ft ²	kg/m ²	lb/ft ²	kg/m ²	lb/ft ²	kg/m ²	lb/ft ²	kg/m ²	lb/ft ²	kg/m ²	lb/ft ²
uni OPB C Rough Vacuum	11.7	2.40	18.3	3.75	7.5	1.54	14.0	2.87	8.1	1.66	14.6	2.99
uni OPB 20% 25%	10.1	2.07	16.1	3.30	6.9	1.41	13.4	2.74	7.3	1.50	13.8	2.83

Permissible Tensile Strength

Belt material	POM		PP		PE	
	N/m	lbf/ft	N/m	lbf/ft	N/m	lbf/ft
uni OPB 4V uni OPB 8	22000	1507	11000	1507	6600	452
uni OPB 4	11000	754	5500	377	3300	226
uni OPB 8P uni OPB 8M	8900	610	8900	610	6600	452

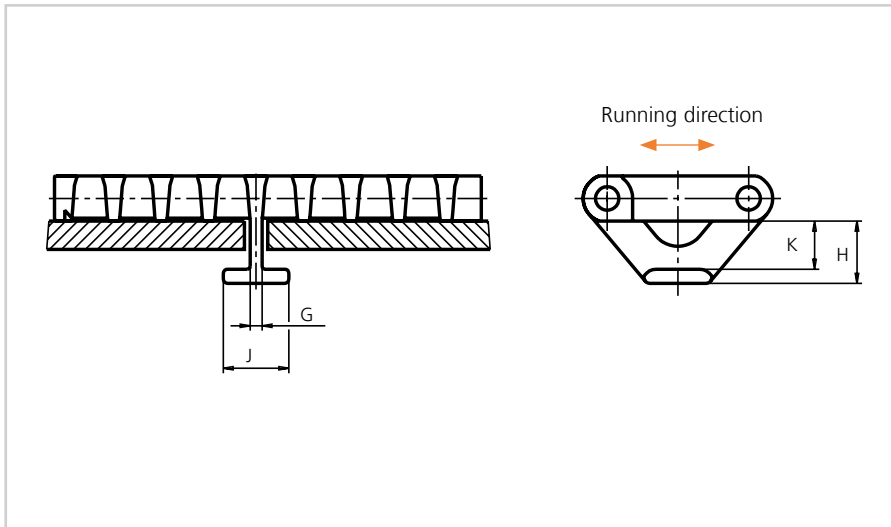
Made-To-Order Accessories | Tab

uni OPB Tab
Dimensions

	mm	in.
G	4.2	0.17
H	22.0	0.87
J	23.2	0.92
K	17.0	0.67

Note: When using tabs, please verify sufficient clearance to the shaft.
 Max. shaft diameter = Sprocket pitch diameter - 63.5 mm (2.50 in.).
 When using square shafts verify that the diagonal does not exceed max. diameter.
 Example: Sprocket z = 6:
 Max. shaft diameter 100.0 - 63.5 = \varnothing 36 mm (3.94 - 2.50 = \varnothing 1.4 in.).

Made-To-Order Material
POM-D, POM-LF and PP

Note: When using a belt system with tabs the temperature should be constant. Please note that the tabs are not always placed in the middle of the belt.

Made-To-Order Accessories | Product Support



uni OPB
Product Support No Cling



uni OPB
Product Support No Clings with Ribs

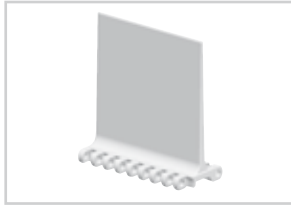

uni OPB
Product Support Flat

Dimensional Sketches

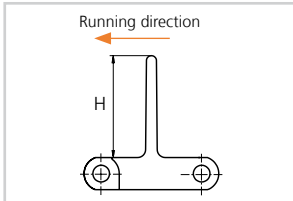

uni OPB
Product Support No Cling and Flat

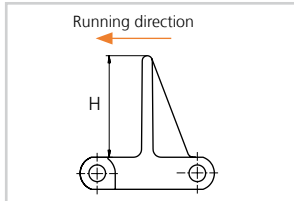

uni OPB
Product Support No Cling with Ribs

Made-To-Order Materials

PPHW

Dimensions

Style	H		Width		
	mm	in.	Type	mm	in.
uni OPB 4 Product Support No Cling	50.8	2.00	K600	151.0	5.94
	76.2	3.00			
	101.6	4.00			
uni OPB 4 Product Support No Cling with Ribs	50.8	2.00	K600	151.0	5.94
	76.2	3.00			
	101.6	4.00			
uni OPB 4V 23F Product Support No Cling	50.8	2.00	K600	151.0	5.94
	76.2	3.00			
uni OPB 4V 23F Product Support No Cling with Ribs	50.8	2.00	K600	151.0	5.94
uni OPB 8 OPB 8P OPB 8M Product Support No Cling	50.8	2.00	K600	151.0	5.94
	76.2	3.00			
	50.8	2.00			
uni OPB 8 OPB 8P OPB 8M Product Support No Cling with Ribs	50.8	2.00	K600	151.0	5.94
	76.2	3.00			
	101.6	4.00			
uni OPB 8 Product Support Flat	152.4	6.00	K600	151.0	5.94

* Minimum bricklaid indent for uni OPB product support is 21.0 mm (0.83 in.). Increment: 8.4 mm (0.33 in.).

Made-To-Order Accessories | Finger Plate

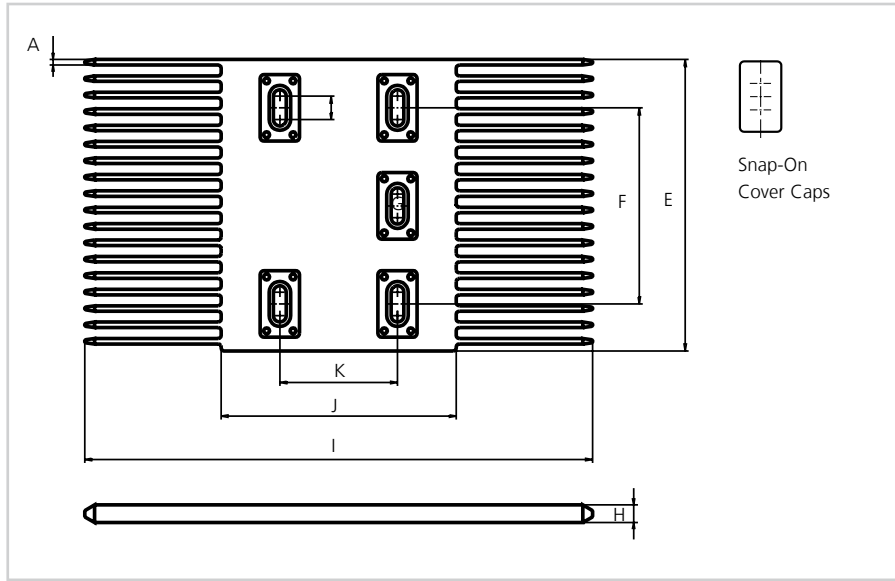

Dimensions

	mm	in.
A	2.8	0.11
E	149.0	5.87
F	100.0	3.94
G	12.0	0.47
H	9.0	0.35
I	259.0	10.20
J	120.0	4.72
K	60.0	2.36

uni OPB Finger Plate Type 3

All belt systems from uni-chains are available in a raised rib version and can be supplied with matching finger plates, also called combs. The finger plates are supplied with cover caps which can be attached when the finger

plate has been installed. The cover caps can be removed by using a screwdriver that can be inserted between the cover and finger plates.

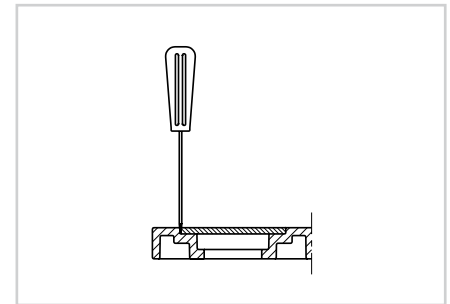

Made-To-Order Selection



uni CPB
with Thread Inserts





uni CPB 20% Rough
with Thread Inserts

The thread inserts allow for easy attachment of fixtures to the belt.

Available insert size M5.

Depending on the size and shape of the attachment, attention should be paid to how the will influence on the backflex radius of the belt.

-  Straight running
-  50.8 mm (2.00 in.)
-  8.0 mm (0.31 in.)
-  **Materials** See page 11
-  85 mm (3.3 in.)
-  See pages 102 and 103
-  See page 171
-  **PA6.6 N**

Made-To-Order Materials

POM-NLAS, POM-NL

Made-To-Order Bricklaid Belt Widths

mm	in.	mm	in.	mm	in.	mm	in.
150	5.9	651	25.6	1151	45.3	1652	65.0
200	7.9	701	27.6	1201	47.3	1702	67.0
250	9.8	751	29.6	1252	49.3	1752	69.0
300	11.8	801	31.5	1302	51.3	1802	70.9
350	13.8	851	33.5	1352	53.2	1852	72.9
401	15.8	901	35.5	1402	55.2	1902	74.9
451	17.8	951	37.4	1452	57.2	1952	76.9
501	19.7	1001	39.4	1502	59.1	2002	78.8
551	21.7	1051	41.4	1552	61.1	2052	80.8
601	23.7	1101	43.3	1602	63.1	2102	82.8

On above belt width values, the belt width tolerance on standard materials is +0/-0.4% at 23°C (73° F).

Made-To-Order Selection

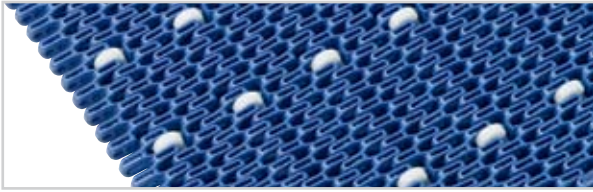

uni Flex SNB with Rollers
 ø17 x 5.5 mm (ø0.67 x 0.22 in.)

Dimensional Sketch

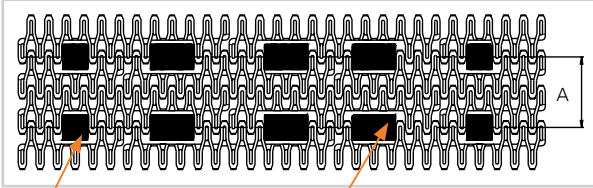









Rollers are available in widths:
 5.5, 17 and 30 mm
 (0.22, 0.67 and 1.18 in.)

Roller
 ø17 x 17 mm (ø0.67 x 0.67 in.)

Roller
 ø17 x 30 mm (ø0.67 x 1.18 in.)

Dimensions

	mm	in.
A min.	50.8	2.00

-  Side flexing
-  12.7 mm (0.50 in.)
-  ø5 mm (0.20 in.)
-  Patented
-  See page 11
-  50 mm (2.0 in.)
-  See page 135
-  See page 171
- 

PA6.6	N	B	PE	W
SS304		SS316		

Made-To-Order Materials

POM-D, PP, PA6.6 and Roller Material POM-D

Made-To-Order Accessories

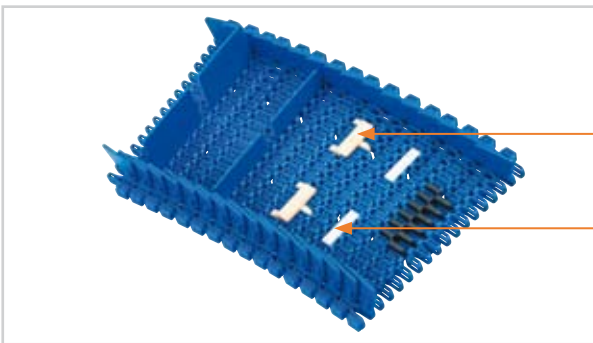

Rubber Support

Product Support low

Dimensions

Style	H		Width		Length	
	mm	in.	mm	in.	mm	in.
Rubber Support	4.0	0.16	43.0	1.69	14.0	0.55
Product Support low	4.0	0.16	42.0	1.65	10.5	0.41

Made-To-Order Materials

Roller: POM-D and Rubber 01N

Accessories | Retainer Rings



uni Retainer Rings™

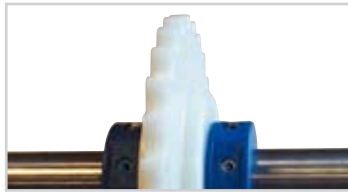

uni Retainer Rings™

Dimension

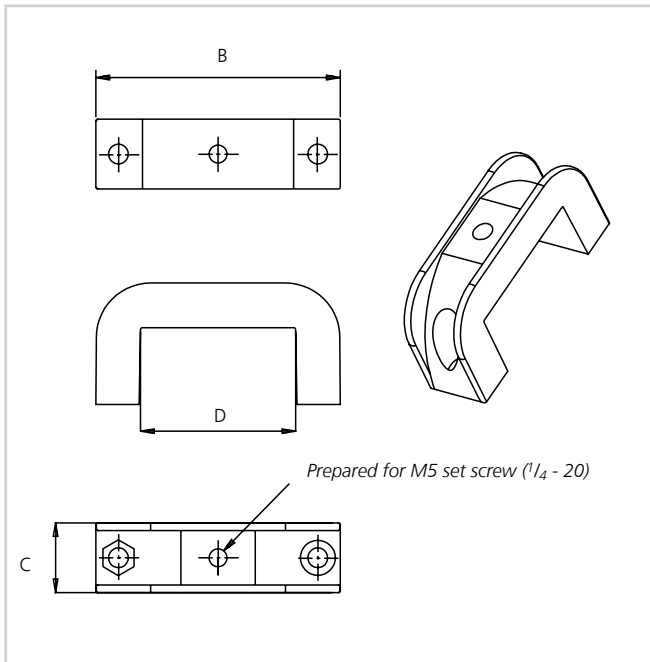
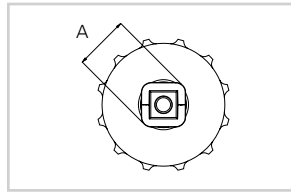

uni Retainer Rings™ D	B		C		A*	
	mm	in.	mm	in.	mm	in.
ø20	39	1.5	14	0.6	ø39	ø1.5
ø25	44	1.7	14	0.6	ø44	ø1.7
ø30	50	2.0	16	0.6	ø50	ø2.0
ø40	63	2.5	18	0.7	ø63	ø2.5
ø50	75	3.0	18	0.7	ø75	ø3.0
■40 x 40 mm	63	2.5	18	0.7	ø80	ø3.1
■50 x 50 mm	80	3.1	18	0.7	ø103	ø4.1
■60 x 60 mm	95	3.7	18	0.7	ø124	ø4.9
ø1"	44	1.7	14	0.6	ø44	ø1.7
ø1.5"	63	2.5	18	0.7	ø63	ø2.5
ø2"	75	3.0	18	0.7	ø75	ø3.0
■1" x 1"	44	1.7	14	0.6	ø52	ø2.0
■1.5" x 1.5"	63	2.5	18	0.7	ø80	ø3.1
■2.5" x 2.5"	95	3.7	18	0.7	ø124	ø4.9

* Use sprocket sizes that ensure that the belt or chain do not conflict with uni Retainer Rings™

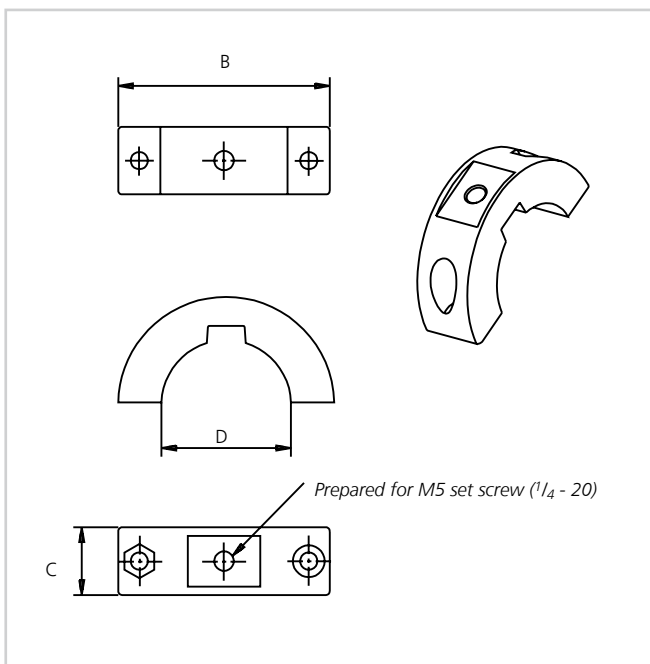

uni Retainer Rings™	uni Reference no.	
	set of 4 rings	set of 20 rings
ø20	95PA6RD20MMB4	95PA6RD20MMB20
ø25	95PA6RD25MMB4	95PA6RD25MMB20
ø30	95PA6RD30MMB4	95PA6RD30MMB20
ø40	95PA6RD40MMB4	95PA6RD40MMB20
ø50	95PA6RD50MMB4	95PA6RD50MMB20
■40 x 40 mm	95PA6SQ40MMB4	95PA6SQ40MMB20
■50 x 50 mm	95PA6SQ50MMB4	95PA6SQ50MMB20
■60 x 60 mm	95PA6SQ60MMB4	95PA6SQ60MMB20
ø1"	95PA6RD10INCHB4	95PA6RD10INCHB20
ø1.5"	95PA6RD15INCHB4	95PA6RD15INCHB20
ø2"	95PA6RD20INCHB4	95PA6RD20INCHB20
■1" x 1"	95PA6SQ10INCHB4	95PA6SQ10INCHB20
■1.5" x 1.5"	95PA6SQ15INCHB4	95PA6SQ15INCHB20
■2.5" x 2.5"	95PA6SQ25INCHB4	95PA6SQ25INCHB20

* Set of 4 rings = 4 complete uni Retainer Rings (8 half rings, 8 screws and 8 nuts).

Standard Material and Color

PA6-GF **B**

Technical Data Sheet for Belt & Chain Applications | Metric

Company/Customer:
Contact person:
End user:

Technical Data

1. Industry:						
2. Application:						
3. Product type:						
4. Wrapping/Container: <input type="checkbox"/> None <input type="checkbox"/> Plastic containers <input type="checkbox"/> Cardboard <input type="checkbox"/> Shrink wrapped <input type="checkbox"/> Flow pack <input type="checkbox"/> Wood						
<input type="checkbox"/> Plastic trays <input type="checkbox"/> Steel trays <input type="checkbox"/> Glass <input type="checkbox"/> Steel cans <input type="checkbox"/> Alu cans <input type="checkbox"/> Cross strapped <input type="checkbox"/> Other:						
5. Item size (mm) L:		xW:	xH:	or Ø:	xH:	Other:
6. Product weight:		kg/item		kg/m		kg/m ²
7. Throughput:		items/min.		kg/min.		Speed m/min.
8. Length of conveyor C-C:		m		Length of belt/chain:	m	Width of belt: m
9. Start/stop operation:		<input type="checkbox"/> No (continuous drive)		<input type="checkbox"/> Yes, no. of stops per hour		<input type="checkbox"/> Product indexing
10. Accumulation:		<input type="checkbox"/> No <input type="checkbox"/> Full		<input type="checkbox"/> Partlylength of accumulation:		
11. Min./max. operating temp.:		°C /		°C		
12. Is the conveyor lubricated?		<input type="checkbox"/> Yes, type:				<input type="checkbox"/> No
13. Is the belt/chain exposed to any chemicals during operation?		<input type="checkbox"/> Yes, type:				<input type="checkbox"/> No
14. Is the belt/chain exposed to any chemicals during cleaning?		<input type="checkbox"/> Yes, type:				<input type="checkbox"/> No
15. Conveyor type:		<input type="checkbox"/> Belt or <input type="checkbox"/> Chain		<input type="checkbox"/> Single row		<input type="checkbox"/> Parallel rows No. of rows
16. Layout (birdseye)		<input type="checkbox"/> Straight running		<input type="checkbox"/> Side flexing		
17. Horizontal layout		<input type="checkbox"/> Straight <input type="checkbox"/> Incline		<input type="checkbox"/> Decline- If in-/decline angle to horizontal:		°
18. <input type="checkbox"/> New conveyor		<input type="checkbox"/> Retrofit		Original belt/chain from:		
19. Belt type:						or chain type:
20. Belt or chain pitch:						Belt or chain color:
21. Belt or chain material:		<input type="checkbox"/> POM <input type="checkbox"/> PP <input type="checkbox"/> PE		<input type="checkbox"/> PA		<input type="checkbox"/> Hardened steel <input type="checkbox"/> Stainless steel <input type="checkbox"/> Other:
22. Pin material:		<input type="checkbox"/> (Plastic <input type="checkbox"/> PP <input type="checkbox"/> PE		<input type="checkbox"/> PA)		<input type="checkbox"/> Hardened steel <input type="checkbox"/> Stainless steel <input type="checkbox"/> Other:
23. Pin retention system:						

Technical Data Sheet for Belt & Chain Applications | Imperial

Company/Customer:
Contact person:
End user:

Technical Data

1. Industry:					
2. Application:					
3. Product type:					
4. Wrapping/Container: <input type="checkbox"/> None <input type="checkbox"/> Plastic containers <input type="checkbox"/> Cardboard <input type="checkbox"/> Shrink wrapped <input type="checkbox"/> Flow pack <input type="checkbox"/> Wood					
<input type="checkbox"/> Plastic trays <input type="checkbox"/> Steel trays <input type="checkbox"/> Glass <input type="checkbox"/> Steel cans <input type="checkbox"/> Alu cans <input type="checkbox"/> Cross strapped <input type="checkbox"/> Other:					
5. Item size (in.) L:	xW:	xH	or Ø:	xH:	Other:
6. Product weight:		lb/item	lb/ft	lb/ft ²	
7. Throughput:		items/min.	lb/min.	Speed	ft/min.
8. Length of conveyor C-C:		ft	Length of belt/chain:	ft	Width of belt: ft
9. Start/stop operation:		<input type="checkbox"/> No (continuous drive)		<input type="checkbox"/> Yes, no. of stops per hour	<input type="checkbox"/> Product indexing
10. Accumulation:		<input type="checkbox"/> No	<input type="checkbox"/> Full	<input type="checkbox"/> Partlylength of accumulation:	
11. Min./max. operating temp.:		°F /		°F	
12. Is the conveyor lubricated?		<input type="checkbox"/> Yes, type:			<input type="checkbox"/> No
13. Is the belt/chain exposed to any chemicals during operation?		<input type="checkbox"/> Yes, type:			<input type="checkbox"/> No
14. Is the belt/chain exposed to any chemicals during cleaning?		<input type="checkbox"/> Yes, type:			<input type="checkbox"/> No
15. Conveyor type:		<input type="checkbox"/> Belt or	<input type="checkbox"/> Chain	<input type="checkbox"/> Single row	<input type="checkbox"/> Parallel rows No. of rows
16. Layout (birdseye)		<input type="checkbox"/> Straight running		<input type="checkbox"/> Side flexing	
17. Horizontal layout		<input type="checkbox"/> Straight	<input type="checkbox"/> Incline	<input type="checkbox"/> Decline- If in-/decline angle to horizontal: °	
18. <input type="checkbox"/> New conveyor		<input type="checkbox"/> Retrofit		Original belt/chain from:	
19. Belt type:		or chain type:			
20. Belt or chain pitch:		Belt or chain color:			
21. Belt or chain material:		<input type="checkbox"/> POM	<input type="checkbox"/> PP	<input type="checkbox"/> PE	<input type="checkbox"/> PA <input type="checkbox"/> Hardened steel <input type="checkbox"/> Stainless steel <input type="checkbox"/> Other:
22. Pin material:		<input type="checkbox"/> (Plastic	<input type="checkbox"/> PP	<input type="checkbox"/> PE	<input type="checkbox"/> PA) <input type="checkbox"/> Hardened steel <input type="checkbox"/> Stainless steel <input type="checkbox"/> Other:
23. Pin retention system:					

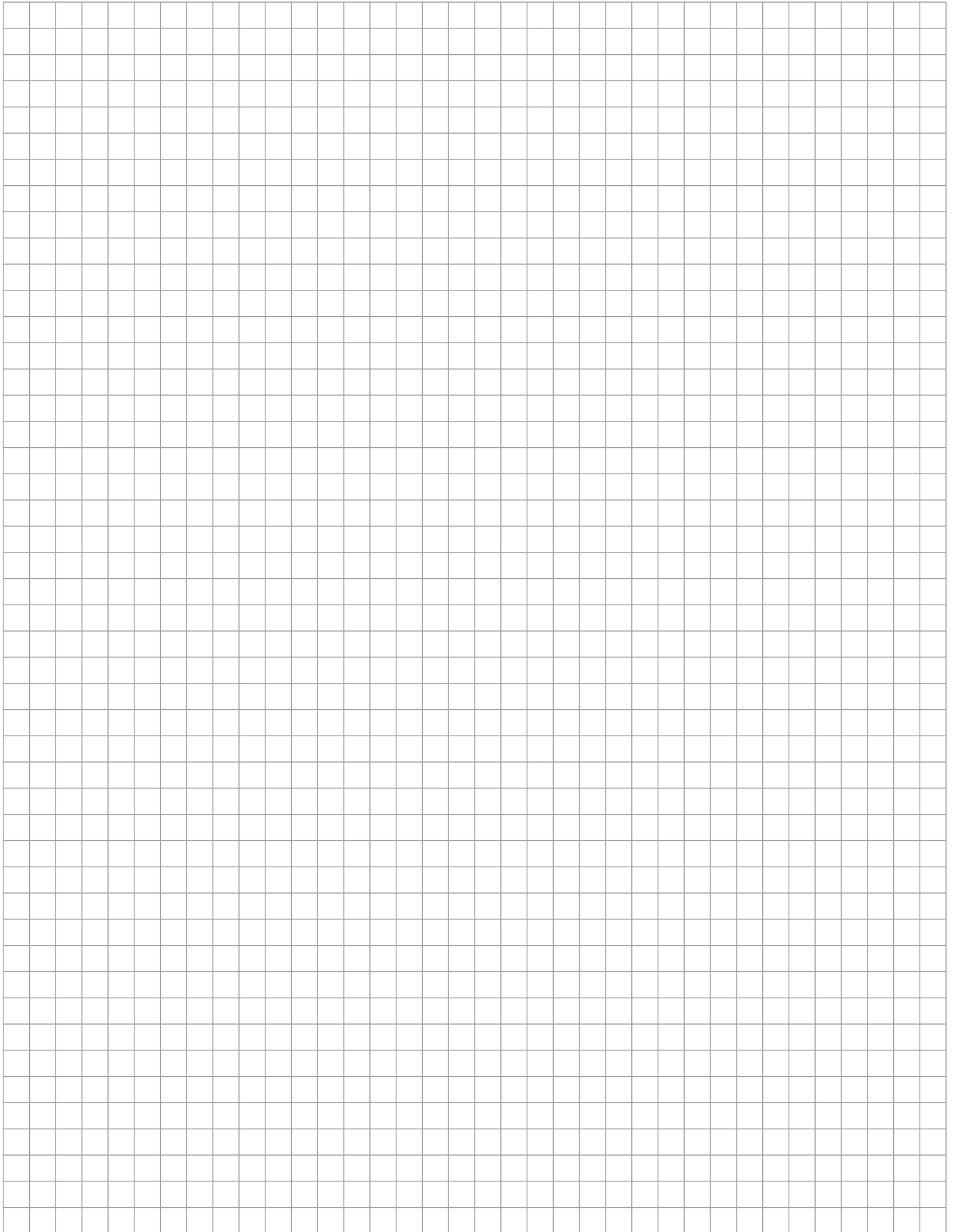

Disclaimer

Ammeraal Beltech Modular A/S provides this catalog as a service and for information purposes only. The material and contents are provided without warranty of any kind. This catalog is not intended to be used as a substitute for advice from our engineers and our official guidelines. While we attempt to maintain the information in this catalog as accurately as possible, it may contain errors or omissions for which we deny any liability.

Ammeraal Beltech Modular A/S is not responsible for any property damage or personal injury, direct or indirect damage from failure or down time in production caused by improper equipment construction. Ammeraal Beltech Modular A/S cannot be held responsible for the incorrect application, operation and/or abuse of our products.

Ammeraal Beltech Modular A/S does not guarantee that the design and/or operational function of any equipment that incorporates uni-chains products, conforms to local, state, and/or federal regulations. Nor does Ammeraal Beltech Modular A/S warrant that standards relating to safety aspects such as public and worker safety, safety guards, fire and sanitation safety, or any other safety regulations are met by such equipment or products.

All users should read our "Warnings" and "Design Safety Guidelines" before using our products.

Warnings

Fire

uni-chains plastic products are, unless clearly specified, made from materials which support open flame. Products made from POM material (D, I, LF and SLF), when so exposed, will emit toxic fumes. uni-chains plastic products should therefore not be exposed to extreme temperatures or open flame. Special care should be taken when undertaking repair work particularly when welding at a conveyor if the conveyor is equipped with plastic chains or belts.

Personal Protection

Always use safety glasses when installing or repairing chains and belts and while securing or removing pins. Use only suitable tools in good condition. The weight of some products calls for the use of safety shoes. When installing/removing or repairing chains or belts on a conveyor, the motor must be turned off.

Design Safety Guidelines

Most plastic products will lose their mechanical properties if exposed to the sun or ultraviolet beams, which can lead to chain or belt breakage. This can also happen if the products are exposed to strong chemicals. Generally, this is a problem with pH values lower than 4.5 or higher than 9. Always make sure that there is enough space in the conveyor frame to allow chains and belts to retract or expand when exposed to temperature variations. Never exceed the maximum or minimum temperatures given by Ammeraal Beltech Modular A/S.

Note: The different materials have different temperature limits. Care should be taken with high chain/belt speeds at which friction can lead to heating and subsequently melting of chain/belt as well as wearstrips. Do not exceed speeds recommended by Ammeraal Beltech Modular A/S. Use only original uni-chains sprockets with uni-chains belts and chains.

When constructing conveyors it is important to always include sufficient cover around the moving parts to prevent fingers and clothing from being caught in the machinery. Ammeraal Beltech Modular A/S can also supply safety chains and side flexing belts which leave minimal gaps when turning through curves making them safer than regular chains.

Patents

Ammeraal Beltech Modular A/S develops and manufactures products under a dynamic intellectual property portfolio. Products may be protected by one or more patents, utility models, designs or trademarks. A regularly updated list of all publicly available rights is published on our homepage www.unichains.com. At time of print products in this catalog are protected by one or more of the following rights:

US D509,038 S	US 5,027,944	EP 1306323
US D503,841 S	US 5,127,515	EP1445216
US D502,585 S	US 5,307,923	DE 10200604437
US 6,857,517 B2	US 5,379,883	US 6857517
US 6,758,329	US 5,697,492	PCT/DK2007/000201
US 6,662,938	DE 69109610	
DE/EP 0931736	FR/EP 0480863	
DK/EP 0931736	GB/EP 0480863	
IT/EP 0931736	IT/EP 0480863	
NL/EP 0931736	DE 4312864	
US 6,073,756	GB 2309062	
US 6,216,854	DE 69506772	
DK 174527	FR/EP 0680898	
GB 2352220	GB/EP 0680898	
IT 1320239	IT/EP 0680898	
US 6,390,288	NL/EP 0680898	
US 6,412,625	SE/EP 0680898	
US 5,482,156	MR 1995 00926	
US 5,305,869	EP 1655242	

Trade Marks

Ammeraal Beltech Modular A/S is in possession of the following registered trade marks:

uni-chains®
Single Link®
Snap Link®

Quality Assurance System

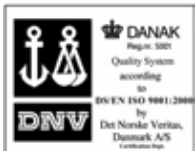

The quality assurance system of Ammeraal Beltech Modular A/S is certified according to ISO 9001.

©2008, Ammeraal Beltech Modular A/S. Copying or reproduction of this catalog is prohibited without written permission. Ammeraal Beltech Modular A/S reserves the right to make changes without notice. The drawings are according to American projection. The drawings belong to Ammeraal Beltech Modular A/S and are not to be used or copied without the permission in writing from Ammeraal Beltech Modular A/S.

Ammeraal Beltech Modular



Argentina

Bandax Argentina S.A.
tel: +54 11 4717 5151
fax: +54 11 4717 6777
e-mail: bandax@bandax.com

Australia

Heat & Control Pty. Ltd.
tel: +61 7 3877 6333
fax: +61 7 3343 8371
e-mail: uni@heatandcontrol.com.au

Australia

Renold Australia Pty. Ltd. (Chains)
tel: +61 3 9262 3333
fax: +61 3 9561 8561
e-mail: melsmg@renold.com.au

Australia

Rydell Industrial Co.
tel: +61 3 9555 7922
fax: +61 3 9553 3908
e-mail: salesvic@rydell.com.au

Austria

Ammeraal Beltech GmbH Austria
tel: +43 1292 9372
fax: +43 1292 8906
e-mail: info@ammeraalbeltech.at

Austria

Katena Stahlgelenketten GmbH
tel: +43 1292 1071
fax: +43 1292 9762
e-mail: office@katena.at

Belarus

LTD Asboga
tel: +375 17 287 3727
fax: +375 17 285 6487
e-mail: tanja_v@unichains.ru

Belgium

Ammeraal Beltech N.V.
tel: +32 2466 0300
fax: +32 2466 4272
e-mail: salesgb@ammeraal-beltech.be

Belgium

Ketten Wulf NV
tel: +32 9243 7373
fax: +32 9221 5603
e-mail: service@ketten-wulf.be

Brazil

Sampla Belting
tel: +55 11 2144 4500
fax: +55 11 2144 4550
e-mail: sampla@sampla.com.br

Bulgaria

Alexandris Engineering LTD
tel: +35 9326 07540
fax: +35 9326 76221
e-mail: alexandris_plovdiv@alexandris.gr

Canada

Ammeraal Beltech Modular, Inc.
tel: +1 610 372 1800
fax: +1 610 372 3590
e-mail: sales@unichains.com

Chile

Ammeraal Beltech Chile S.A.
tel: +56 2669 6975
fax: +56 2669 6709
e-mail: ventas@ammeraalbeltech.cl

Chile

Ducasse Comercial Ltda.
tel: +56 2696 3126
fax: +56 2698 3873
e-mail: ventas@ducasse.cl

China

AA Industrial Belting (Shanghai) Co. Ltd.
tel: +86 21 6534 4690
fax: +86 21 6548 0430
e-mail: webmaster@ammeraalbeltech.com.cn

Colombia

Oxicortes S.A.
tel: +57 4262 0323
fax: +57 4262 3912
e-mail: oxicortes@epm.net.co

Czech Republic

Ammeraal Beltech s.r.o.
tel: +420 567 563 631
fax: +420 567 330 637
e-mail: prodej@ammeraalbeltech.cz

Czech Republic

Murtfeldt Plasty s.r.o.
tel: +420 272 706 052
fax: +420 272 706 101
e-mail: info@murtfeldt.cz

Denmark

Ammeraal Beltech Modular A/S
tel: +45 7572 3100
fax: +45 7572 3348
e-mail: admin@unichains.dk

Egypt

United Trading Co.
tel: +20 224510793
fax: +20 224530255
e-mail: egyunited@yahoo.com

Estonia

Tecnobalt Eesti OÜ
tel: +372 661 3160
fax: +372 661 3165
e-mail: info@tecnobalt.ee

Ecuador

Tadeler S.A.
tel: 593 4265 1272
fax: 593 4600 5978
e-mail: tadeler@tadeler.com

Finland

Ammeraal Beltech Oy
tel: +358 207 911 400
fax: +358 207 911 450
e-mail: info@ammeraalbeltech.fi

Finland

SKS-mekaniikka OY
tel: +358 20 764 61
fax: +358 20 764 6824
e-mail: mekaniikka@sk.fi

France

Ammeraal Beltech S.A.S.
tel: +33 3 2090 3600
fax: +33 3 2032 2917
e-mail: client@ammeraalbeltech.fr

France

Ammeraal Beltech Modular A/S France
tel: + 33 3 4467 4692
fax: + 33 3 4467 4693
e-mail: france@unichains.com

Greece

George P. Alexandris S.A.
tel: +30 210 411 1841 5
fax: +30 210 411 8171
e-mail: gpalex@alexandris.gr

Germany

Ammeraal Beltech Modular GmbH
tel: +49 5971 91437 0
fax: +49 5971 91547 5
e-mail: admin@unichains.de

Hungary

Ammeraal Beltech Lőrincz Ltd.
tel: +36 2342 7510
fax: +36 2342 7511
e-mail: info@ammeraalbeltech.hu

Hungary

Tech-Con Hungaria KFT
tel: +36 1412 4173
fax: +36 1412 4171
e-mail: agnes@tech-con.hu

Iceland

Bakverk-Heidsala EFT
tel: +35 4517 2220
fax: +35 4517 2221
e-mail: bakverk@bakverk.is

India

Lakhotia Beltings Private Ltd.
tel: +91 80 28364995
fax: +91 80 41170559
e-mail: lakhotiabelling@vsnl.net

Ireland

Ammeraal Beltech Modular A/S UK
tel: +44 121 559 0377
fax: +44 121 559 0373
e-mail: admin@unichains.co.uk

Israel

M. Marcus Conveyor Supply Ltd.
tel: +972 3941 5150
fax: +972 3941 5575
e-mail: m_marcus@netvision.net.il

Italy

uni-chains italia s.r.l.
tel: +39 0522 922470
fax: +39 0522 922508
e-mail: unichains@unichains.it

Japan

Nihon Unichains Co., Ltd.
tel: + 81 52 209 2977
fax: +81 52 231 1102
e-mail: s-sakai@unichains.co.jp

Latvia

Peruza Ltd.
tel: +371 67248036
fax: +371 67312873
e-mail: peruza@peruza.lv

Lithuania

Technobalta UAB
tel: +370 52 602 503
fax: +370 52 653 288
e-mail: lietuva@tecnobalt.com

Luxembourg

Ammeraal Beltech S.a.r.l.
tel: +352 2648 3856
fax: +352 2648 3857
e-mail: sales@ammeraal-beltech.lu

Malaysia

Ammeraal Beltech Sdn. Bhd.
tel: +60 3 8061 8849
fax: +60 3 8061 8935
e-mail: sales.kl@ammeraalbeltech.com.my

Mexico

Linarand S.A. de C.V.
tel: +52 55 5341 8131
fax: +52 55 5341 9912
e-mail: linarand@infosel.net.mx

Netherlands

Ammeraal Beltech B.V.
tel: +31 72 575 1212
fax: +31 72 571 6455
e-mail: info@ammeraalbeltech.nl

Norway

Ammeraal Beltech Modular NO
tel: +47 2220 2699
fax: +45 7572 3348
e-mail: salesnordic@unichains.com

New Zealand

Heat & Control Ltd.
tel: +64 9274 4182
fax: +64 9274 5756
e-mail: akl-spares@heatandcontrol.co.nz

New Zealand

Renold New Zealand Ltd.
tel: +64 9828 5018
fax: +64 9828
e-mail: aksales@renold.co.nz

Poland

Derco s.p. z o o
tel: +48 22 664 3887
fax: +48 22 664 3889
e-mail: derco@derco.com.pl

Portugal

Ammeraal Beltech S.A.
tel: +351 22 947 9440
fax: +351 22 941 3081
e-mail: geral@ammeraalbeltech.pt

Portugal

Harker, Sumner S.A.
tel: +351 22 947 8090
fax: +351 22 947 8098
e-mail: accionamentos.ind@harker.pt

Russia

JV Megadrive Ltd.
tel: +375 172 873727
fax: +375 172 856487
e-mail: tanja_v@unichains.ru

Russia

O.O.O. Ammeraal
tel: +7 495 234 2357
fax: +7 495 234 8803
e-mail: ammeraal@mtu-net.ru

Singapore

Ammeraal Beltech Pte Ltd.
tel: +65 6273 9767
fax: +65 6273 5490
e-mail: sales@ammeraalbeltech.com.sg

Slovakia

Ammeraal Beltech s.r.o.
tel: +421 2 5564 8541
fax: +421 2 5564 8543
e-mail: predaj@ammeraalbeltech.sk

South Africa

uni-chains ZA
tel: +27 11 397 2116
fax: +27 11 397 2117
e-mail: unichains@mweb.co.za

South Korea

Ammeraal Beltech Co. Ltd.
tel: +82 31 448 3613 7
fax: +82 31 448 3618
e-mail: amel@ammeraalbeltech.co.kr

Spain

Ammeraal Beltech S.A.
tel: +34 961 2186 38
fax: +34 961 2186 39
e-mail: cem@ammeraalbeltech.es

Spain

CID, S.L.
tel: +34 91 507 2838
fax: +34 91 507 2773
e-mail: cid@cid.es

Sweden

Ammeraal Beltech AB
tel: +46 44 3015
fax: +46 44 43349
e-mail: info@ammeraal-beltech.se

Sweden

Ammeraal Beltech Modular SE
tel: +46 (0)42 212 480
fax: +45 7572 3348
e-mail: salesnordic@unichains.com

Switzerland

Ammeraal Beltech AG
tel: +41 55 2253 535
fax: +41 55 2253 636
e-mail: info@ammeraal-beltech.ch

Switzerland

C. Plüss & Co. AG
tel: +41 44 824 8800
fax: +41 44 824 8818
e-mail: service@pluss.com

Switzerland

Renold (Switzerland) GmbH
tel: +41 44 824 8484
fax: +41 44 824 8411
e-mail: duebendorf@renold.com

Thailand

Ammeraal Beltech Co. Ltd
tel: +66 2902 2604
fax: +66 2902 0422
e-mail: sales@ammeraalbeltech.th.com

Turkey

Mimsan Ithalat Ihracat Konveyör
tel: +90 212 657 8946
fax: +902126510073
e-mail: bant@mimsan.com.tr

Ukraine

ABSC Ukraine Ltd.
tel: +380 563 723211
fax: +380 563 713100
e-mail: ammeraal@ukr.net

United Kingdom

Ammeraal Beltech Modular A/S UK
tel: +44 121 559 0377
fax: +44 121 559 0373
e-mail: admin@unichains.co.uk

United States

Ammeraal Beltech Modular, Inc.
tel: 610 372 1800
fax: 610 372 3590
e-mail: sales@unichains.com

Uruguay

Nevinox S.R.L.
tel: 598 (2) 509 1404*
fax: 598 (2) 509 1404 Extension 26
e-mail: direccion@nevinnox.com

www.unichains.com